

# CRYSTEEL'S DEUCE



P.O. Box 178  
52182 Ember Road  
Lake Crystal, MN 56055

[www.crysteel.com](http://www.crysteel.com)  
[crysteel@crysteel.com](mailto:crysteel@crysteel.com)  
(507) 726-2728 (800) 533-0494

1902 Route 57 South  
Fulton, NY 13069

**DATE PURCHASED** \_\_\_\_\_  
**BODY SERIAL NUMBER** \_\_\_\_\_  
**HOIST SERIAL NUMBER** \_\_\_\_\_  
**CYLINDER SERIAL NUMBER** \_\_\_\_\_  
**DEALER** \_\_\_\_\_  
**ADDRESS** \_\_\_\_\_  
**PHONE** \_\_\_\_\_

**FOREWORD**

The Deuce is a dual purpose dump body capable of dumping to the rear or to the left (driver's) side. The left side is a 'dump through' side, hinged at the top and latched at the bottom. The right side folds down for easy loading and unloading of pallets or other materials. The tailgate is a 'quick-drop' design allowing the tailgate to be folded down or hinged at the top.

This manual contains the information needed for the proper installation and operation of Crysteel's Deuce body and hoist. With proper installation, use, and regular maintenance, the Deuce will give many years of trouble free service.

When ordering parts, be sure to give serial number of the body, hoist, and cylinder. The serial number of the body is found stamped into the front of the body near the trip lever. The serial number of the hoist is stamped into the cylinder mounting plate. The serial number of the cylinder is stamped on the barrel of the cylinder near the base. For future reference, copy these numbers NOW in the space provided above. Order parts by number and description as given in the parts listing in this manual.

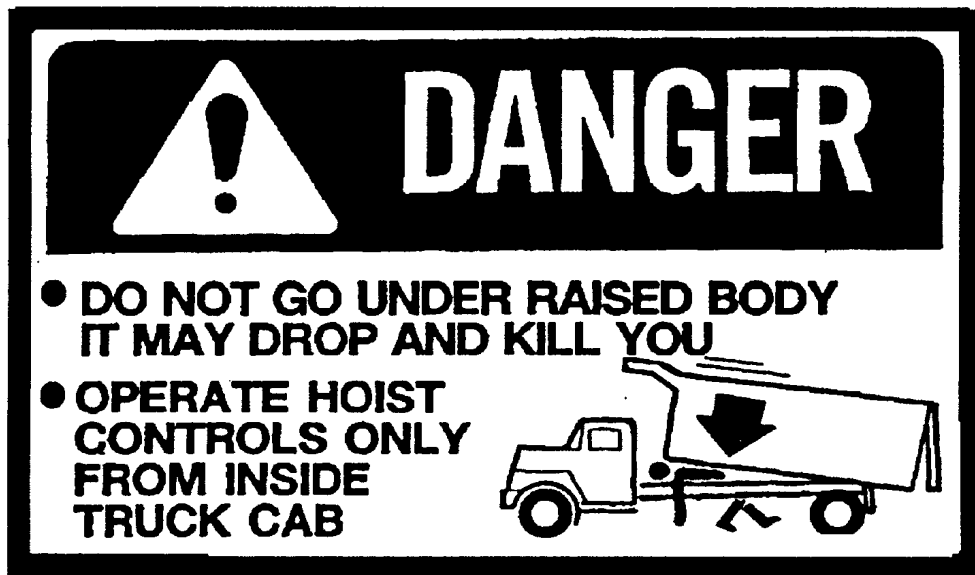

## OPERATION AND USE

1. For gear pump hydraulic systems, engage PTO from cab. Then:
  - To raise the hoist, press down on the knob of the hoist control lever and pull the lever back.
  - To hold the body in a raised position, place the control lever in its center detent position.
  - To lower the hoist, press down on the knob of the hoist control lever and push the control lever forward.
  - **ALWAYS** return the hoist control lever to its center detent position after each use.
2. For electric power unit systems:
  - To raise the hoist, press and hold the 'UP' button on the push–button control.
  - To hold the body in a raised position, release the push–button.
  - To lower the hoist, press and hold the 'DOWN' button on the push–button control
  - **ALWAYS** release the push–buttons after each use.
3. The body **MUST** be all the way down before changing the dumping direction. To change the dumping direction, move the handle from one position to the other. The Deuce is equipped with an interlock to prevent changing the dumping direction once the body is raised.
4. To prop the body in a raised position for servicing:
  - **SET DUMPING DIRECTION TO REAR.**
  - Raise the body half way and shut off all power.
  - Raise the body prop to its free–standing position.
  - Slowly lower the body until it rests on the body prop.
5. To lower the body prop:
  - Raise the body half way up and shut off all power.
  - Lower the body prop to its storage position.
  - Lower the body.
6. **DO NOT LEAVE THE PTO IN GEAR WHILE TRANSPORTING. THIS CAN CAUSE SEVERE DAMAGE TO THE PTO OR HYDRAULIC PUMP/VALVE.**
7. The hydraulic system should be drained, flushed and refilled with proper hydraulic fluid at regular intervals. **CAUTION: NEVER use hydraulic BRAKE FLUID in the hydraulic system.**

## SOME DO'S AND DON'TS FOR SAFE AND LONG SERVICE

1. Use the proper hydraulic fluid. **KEEP IT CLEAN.** Remember to change it regularly.
2. Lubricate all grease fittings at regular intervals.
3. **ALWAYS** carefully block up the body, using the body prop, before working under it.
4. Do not “race” the engine when unloading.
5. Do not load the hoist beyond its capacity.
6. **DO NOT** tamper with the hydraulic relief valve. This will void the warranty. It can cause severe damage to the hoist and cylinder.
7. Never leave the PTO in gear while transporting. It could ruin the hydraulic pump, the PTO or the transmission.
8. Check all bolts and fittings regularly. Keep them tight.

## TABLE OF CONTENTS



Purchase Record	1
Foreword	1
Operation and Use	2
Some Do's and Don't's	2
Table of Contents	3
General Information	4
Locate Deuce Body / Hoist / Subframe	5
Locate Mounting Plate	6
Drill Truck Frame	6
Weld Mounting Plates to Subframe	6
Select Rear Dumping Direction	7
Hydraulic Systems	8
Install Gear Pump	9
Install Reservoir / Valve	9
Install Hoist Control	9
Install Hoses – Gear Pump	10
Add Hydraulic Fluid	10
Electric Power Unit Mounting – General	11
Install Hoses – Electric Single–Acting	12
Install Hoses – Electric Double–Acting	12
Add Automatic Transmission Fluid	12
Install Grease Zerks and Lubricate	12
Install Wiring, Lights, Reflectors and Decals	13–14
Parts Lists and Diagrams	15–19

# INSTALLATION INSTRUCTIONS

## GENERAL INFORMATION

It is a good idea to look through these installation instructions before beginning to mount the hoist and hydraulic system.

When welding, protect the truck's electrical, air and brake systems by disconnecting, removing or covering. Tighten all nuts and bolts to a consistent level. Use the following table for torque values.

Size	Grade 2 Torque	Grade 5 Torque	Grade 8 Torque
			
1/4-20	3-4 lb-ft	6-7 lb-ft	10-11 lb-ft
1/4-28	4-5 lb-ft	8-9 lb-ft	11-12 lb-ft
5/16-18	8-9 lb-ft	14-15 lb-ft	21-22 lb-ft
5/16-24	9-10 lb-ft	15-16 lb-ft	21-22 lb-ft
3/8-16	17-18 lb-ft	24-26 lb-ft	37-40 lb-ft
3/8-24	19-20 lb-ft	28-30 lb-ft	40-43 lb-ft
1/2-13	38-42 lb-ft	60-65 lb-ft	90-100 lb-ft
1/2-20	43-47 lb-ft	70-75 lb-ft	95-105 lb-ft
5/8-11	75-80 lb-ft	122-130 lb-ft	180-190 lb-ft
5/8-18	85-90 lb-ft	145-150 lb-ft	200-210 lb-ft
3/4-10	132-140 lb-ft	220-230 lb-ft	315-330 lb-ft
3/4-16	152-160 lb-ft	250-260 lb-ft	355-370 lb-ft

## LOCATE DEUCE BODY / HOIST / SUBFRAME

Before placing the Deuce body/hoist/subframe on the truck, measure the length of the truck frame behind the rear axle. The maximum truck frame length that will not affect the operation of the Deuce is 47 1/2 inches, assuming a cab clearance of 3 inches. The minimum truck frame length for supporting the Deuce subframe is 40 1/2 inches, assuming a cab clearance of 3 inches. If the truck frame is longer than 47 1/2 inches, mark the truck frame at the preferred length of 43 inches and cut it off. See Figure 1.

If the frame cannot be shortened to 47 1/2 inches, the cab clearance can be increased by moving the Deuce body/hoist/subframe back. **HOWEVER**, this will affect weight distribution.

The Deuce body, hoist and subframe come pre-assembled. Place the body/hoist/subframe on the truck with 3 inches of cab clearance. See Figure 1.

**NOTE:** If the truck frame has rivets in the top flange, add spacers between the truck frame and subframe, or counter sink the rivet heads into the subframe by drilling holes in the subframe. Do not remove the rivet heads!

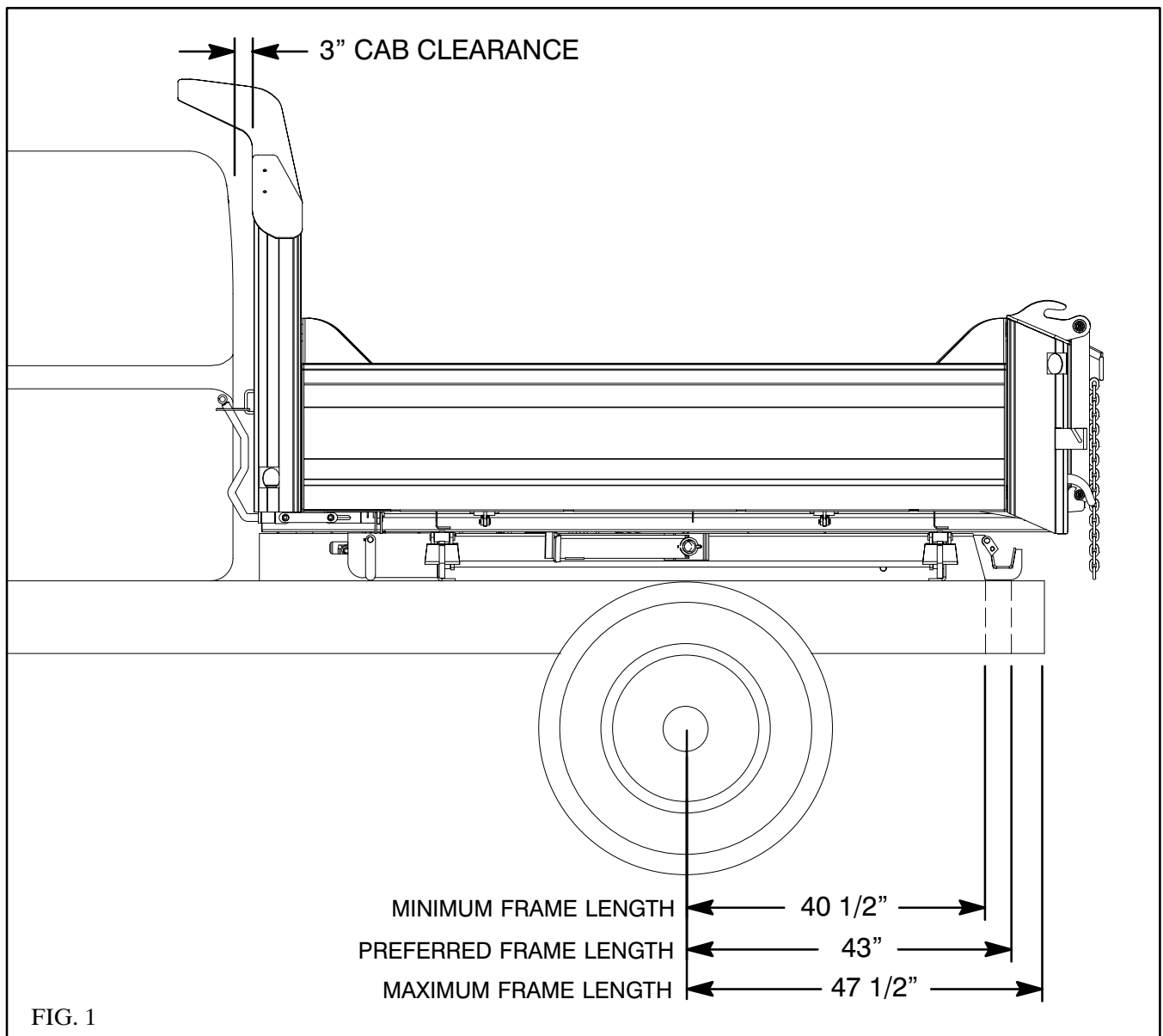

## LOCATE MOUNTING PLATES

There are four mounting plates, two on each side – one near the front crossmember in the subframe and one near the rear crossmember in the subframe. Clamp the mounting plates to the truck frame and to the subframe as shown in Figures 2 and 3. If desired, locate the plates to use existing holes in the truck frame. Mark the mounting plates for drilling. Repeat this for the other side.

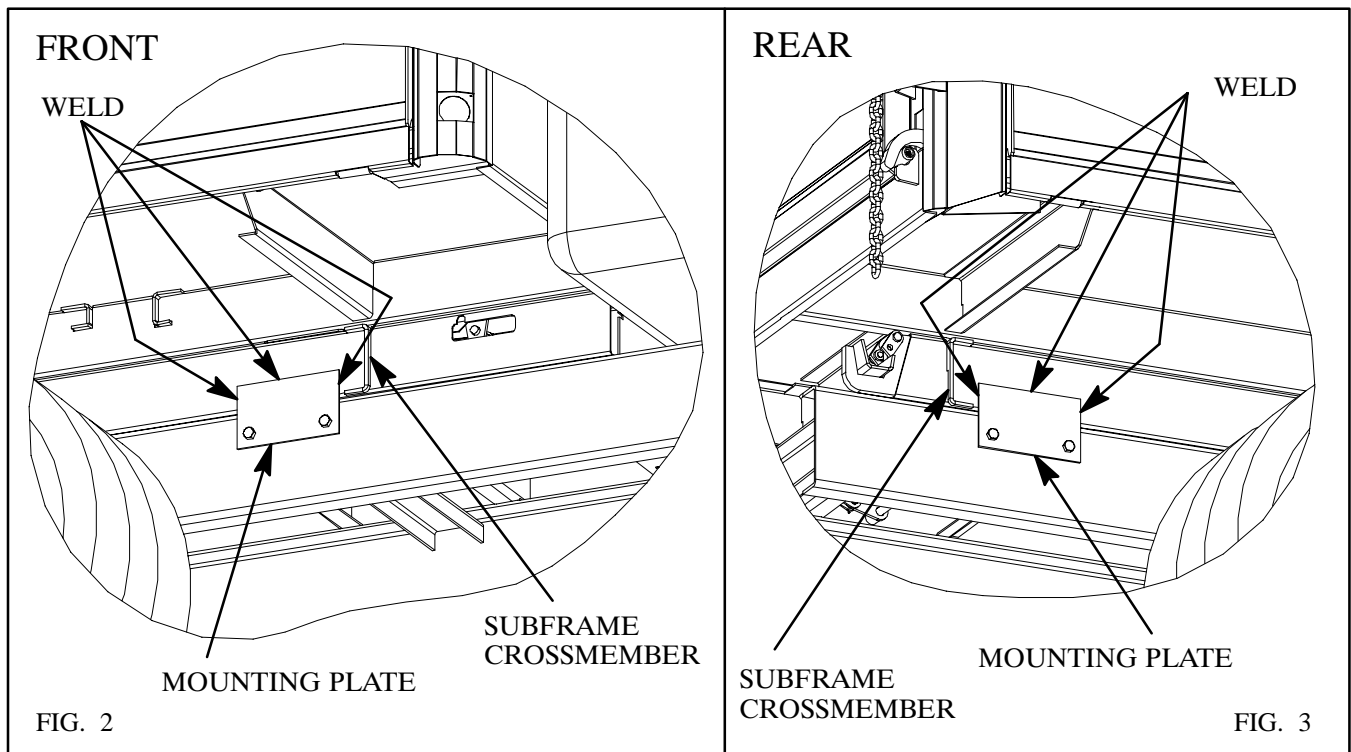

***CAUTION: BE CAREFUL OF BRAKELINES, WIRING, ETC. INSIDE THE TRUCK FRAME WHEN DRILLING THE TRUCK FRAME.***

## DRILL TRUCK FRAME

Drill 21/32” holes in the mounting plates and the truck frame. Bolt the mounting plates in place using 5/8 x 2 cap screws (grade 8), flat washers and hex lock nuts, tightening to 180–190 lb–ft.

## WELD MOUNTING PLATES TO SUBFRAME

Make sure the body/hoist/subframe assembly is correctly located, centered on and square with the truck frame. Continuously weld the mounting plates to the subframe.

## SELECT REAR DUMPING POSITION

The rest of the installation will need to have the body raised. Before raising the body, make sure the dumping direction selector handle is in the 'REAR' dumping position. See Figure 4. Using an overhead hoist, raise the body. Once the body is raised, use the body prop to hold it up or securely block the body in the raised position.

To use the body prop, raise the body, raise the prop arm to its free-standing position and slowly lower the body to rest on the body prop. See Figure 5. The body prop will swing in to support the bottom of the body longbeam.

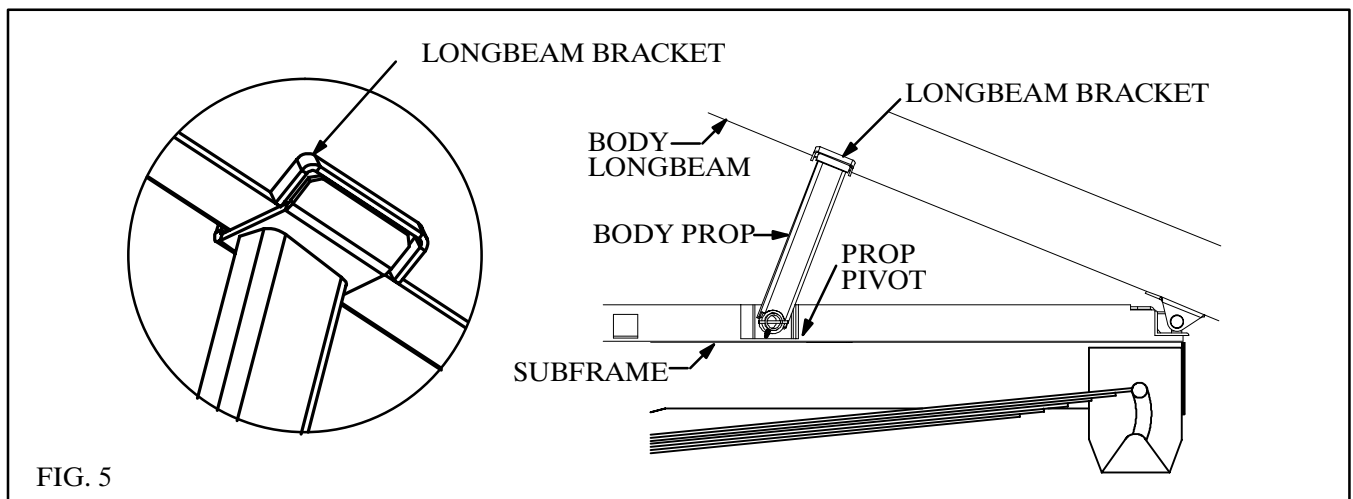
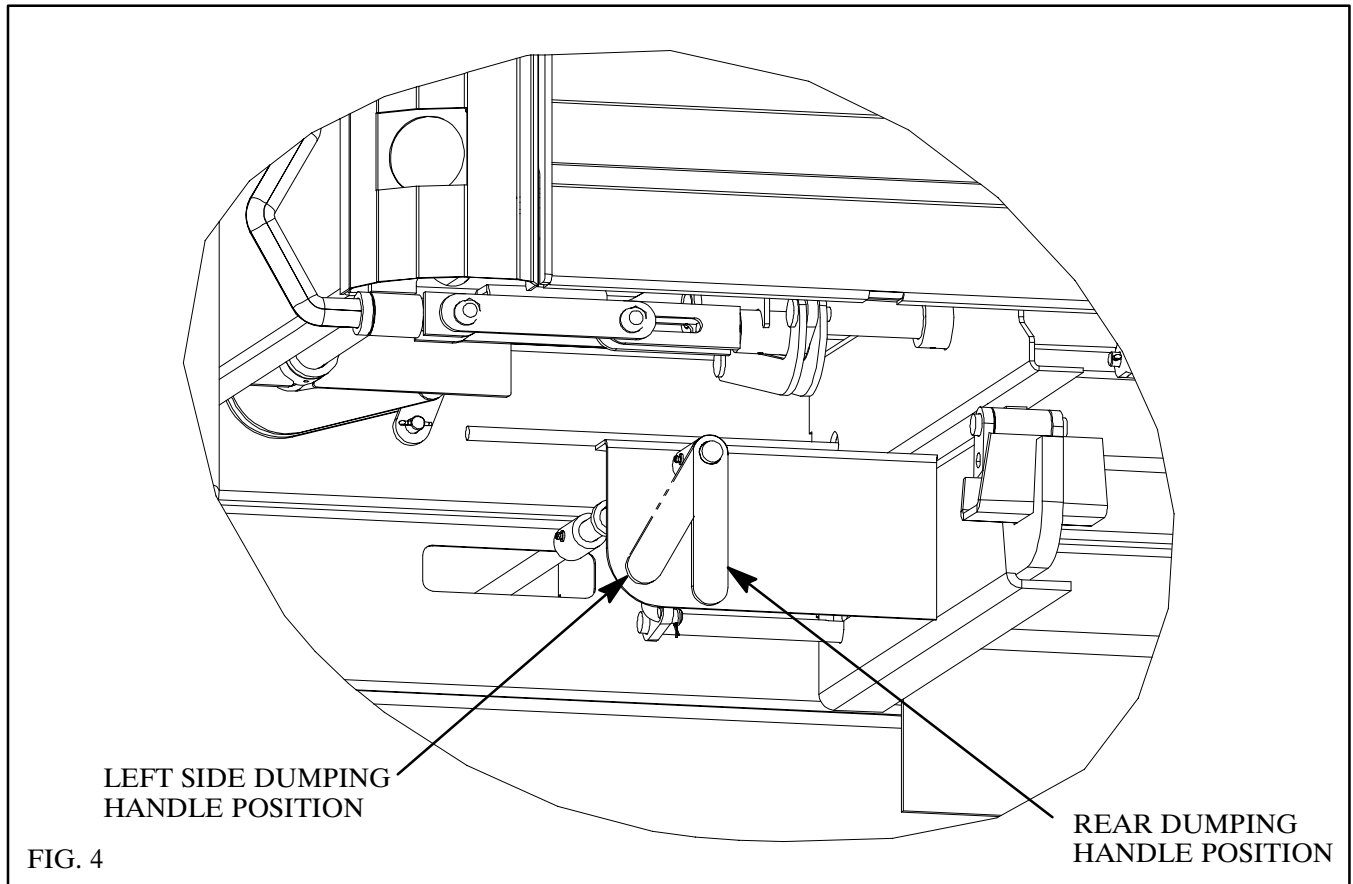

***DO NOT WORK UNDER A RAISED BODY UNLESS THE BODY IS SECURELY BLOCKED OR PROPPED IN THE RAISED POSITION.***



## HYDRAULIC SYSTEMS

Crysteel offers three different hydraulic systems for use with the Deuce. Mounting instructions can be found on the pages shown:

- 4 GPM Gear Pump with Remote Reservoir/Valve ..... Pages 8 to 10
- Electric Pump—Single Acting ..... Pages 11 & 12
- Electric Pump—Double Acting ..... Pages 11 & 12

### INSTALL GEAR PUMP

The gear pump has an SAE 'A' mounting configuration, a 9 tooth splined shaft and a two-bolt mounting flange, and is assembled for counterclockwise rotation. Note: This pump will mount directly to Chelsea's output type 'XE' or Muncie's output type 'R'. Crysteel Manufacturing recommends a PTO ratio of 100–120%. This assures a minimum pump operating speed of 600 RPM. **CHECK THE ROTATION OF THE PTO!** If it is opposite of the engine, then the pump can be used as it is. If the PTO rotation is the same as the engine, then the pump will need to be reversed. (See instructions included with the pump.) Bolt the gear pump to the PTO output flange using 3/8 x 1" cap screws and lock washers.

### INSTALL RESERVOIR / VALVE

The reservoir/valve assembly is intended to be mounted just behind the cab, between the longbeams of the body with the control valve to the back side of the reservoir. See Figure 6. Bolt the reservoir/valve assembly to this mounting bracket using 3/8 x 1" cap screws, flat washers and hex lock nuts.

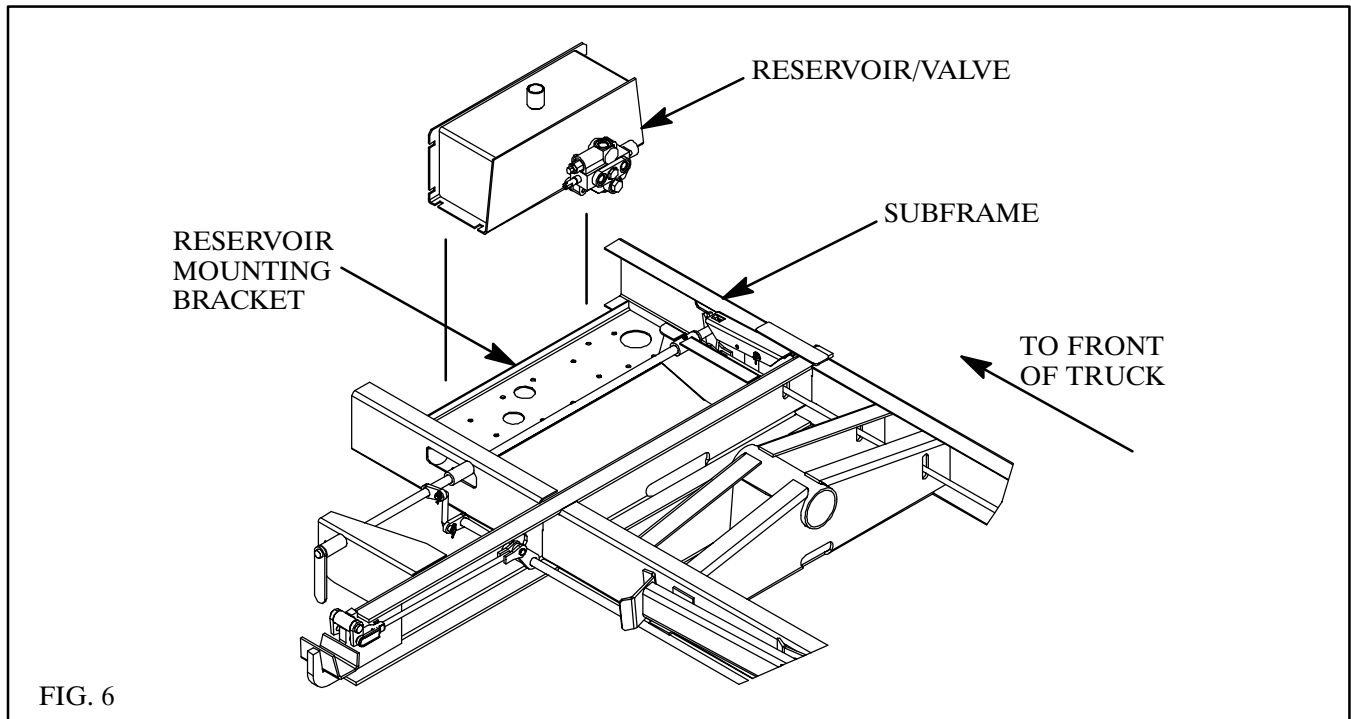
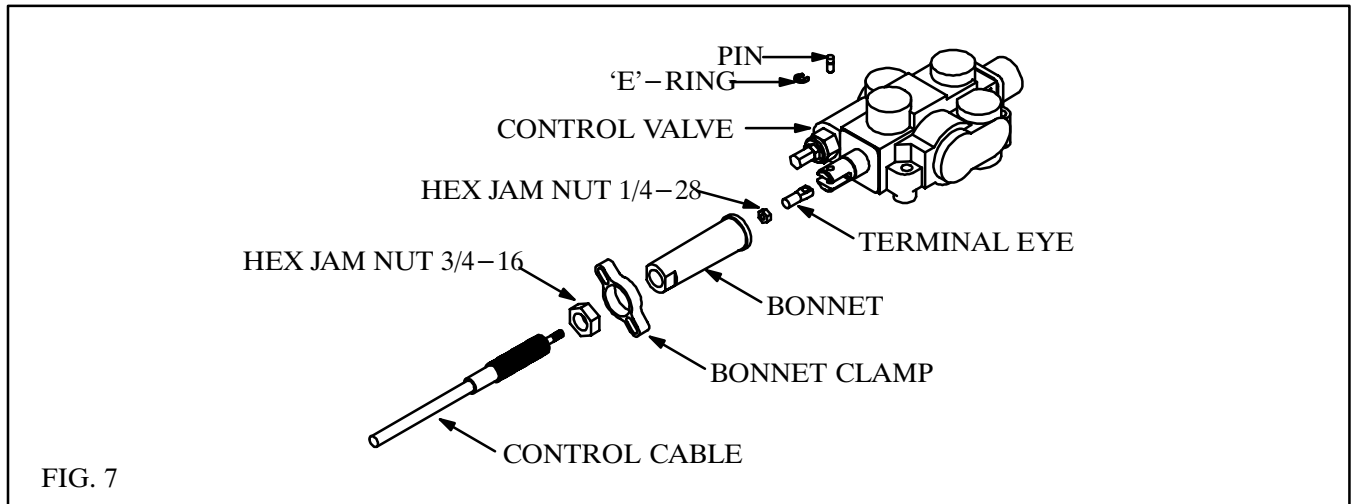

FIG. 6

## INSTALL HOIST CONTROL

Mount the Hoist Control decal on the pedestal taking care to align the holes for the PTO cable and indicator light. Temporarily assemble the valve control head to the pedestal using 5/16 x 2 1/2 machine screws and hex nuts. Place this assembly on the floor of the cab. The pedestal and valve control should angle forward. This makes it convenient for the operator to pull the hoist control lever back to raise the hoist. Make sure there is enough room to operate the valve control and gear shift lever and to adjust the seat. Check below the floor for obstructions and cable routing. Relocate the valve control if necessary. Mark the floor using the pedestal as a template and drill 11/32" holes for the mounting screws and a 3/4" hole for the control cable. Assemble the control cable to the valve control head and assemble the valve control head and cover to the pedestal using 5/16 x 2 1/2 machine screws and hex lock nuts. Insert the control cable through the hole in the floor and mount the pedestal to the floor using 5/16 x 1/2 hex head cap screws, clamping plate (under the floor) and hex lock nuts. Make sure the valve control lever is in its center detent position. Keep the control cable away from hot exhaust pipes and rotating drive shafts. The control cable should not have any sharp bends or kinks in it (these will make the control harder to operate).

Install the 3/4" hex jam nut onto the valve end of the control cable and turn it past the threads. Insert the end of the cable through the bonnet clamp. Install the bonnet onto the control cable and turn it past the threads also. Install the 1/4" hex jam nut and terminal eye on the core rod of the cable; lock the terminal eye to the core rod of the cable using the hex jam nut. Place the terminal eye in the slot of the valve spool; insert the short pin through the valve spool and terminal eye and secure it in place with the 'E' ring. Thread the bonnet onto the end of the cable so it firmly touches the end of the valve. (Do not over- or under-tighten the bonnet as either would move the valve spool out of its neutral position.) Remove two cap screws from opposite corners of the seal retainer plate. Slide the bonnet clamp onto the bonnet and secure it to the valve using the 1/4 x 1 1/4 cap screws, lock washers and flat washers. Lock the bonnet to the cable using the 3/4" hex jam nut. (See Fig. 7.)



## INSTALL HOSES – GEAR PUMP

Study Fig. 8 very carefully before connecting hoses. Install a 90° street elbow and a 3/4" hose barb in the suction port on the bottom of the reservoir. Install a 1 1/16 ORB x 3/4" hose barb in the suction port of the pump and install a 3/4" ID suction hose. Secure the suction hose in place using hose clamps. Install a 1 1/16 ORB x 3/8 NPT adapter and a 3/8 NPT 90° swivel adapter in the 'IN' port of the control valve and a 7/8 ORB x 3/8 NPT adapter in the pressure port of the pump. Connect a 72" long 3/8" hose between the pump and the valve.

Install 90° adapters in the work ports of the control valve and straight adapters in the ports on the cylinder. Connect the shorter 3/8" hose from the 'B' port on the control valve to the base end port on the cylinder; connect the longer 3/8" hose from the 'A' port to the rod end port. This will raise the hoist when the control lever is pulled back and lower it when pushed forward.

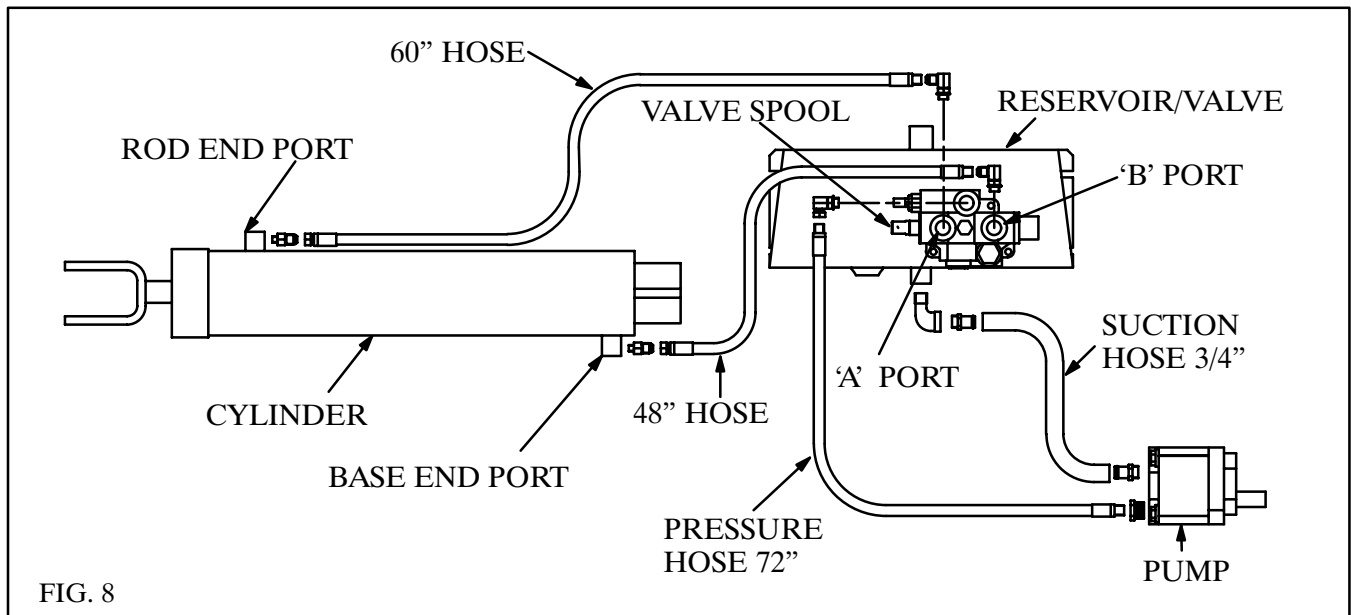

**NOTE:** The 'A' port is the 'power-down' port and has a pressure of only 500–1000 PSI; the 'B' port has full system pressure.

## ADD HYDRAULIC FLUID

Use a quality hydraulic fluid of 150 SSU @ 100°F which contains corrosion and oxidation inhibitors and a foam depressant. This is approximately the equivalent of SAE 10W or lighter weight oil. Initially fill the reservoir with 10 quarts of hydraulic fluid. **DO NOT OVERFILL THE RESERVOIR!**

***KEEP THE OIL CLEAN! USE CLEAN CONTAINERS, FUNNELS AND OTHER EQUIPMENT!***

With normal use and working conditions the hydraulic oil should be changed annually. The breather cap should be cleaned every time the hydraulic oil is changed. With heavy use or very dusty working conditions the hydraulic oil should be changed more often.

**NOTE:** If the pump does not pump oil, pressurize the reservoir and engage the pump with the engine at slow idle. Once the pump is working, release the pressure and install the breather cap.

## ELECTRIC POWER UNIT MOUNTING – GENERAL

The electric power unit is intended to be mounted just behind the cab, between the longbeams of the body. Place the rubber pad under the end of the tank. Bolt the pump to the bracket provided using the 3/8 x 1 cap screws and flat washers. Clamp the end of the poly tank to the reservoir mounting bracket with a long tie strap. See Figure 9.

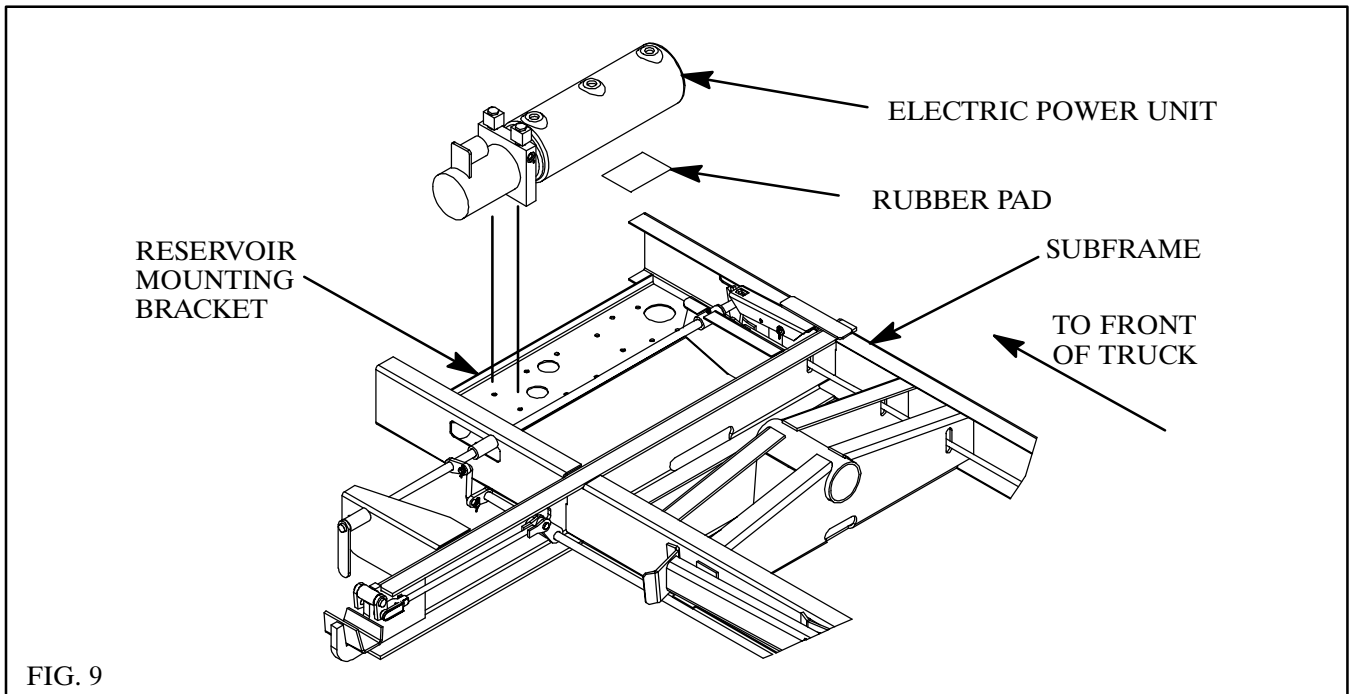

Connect the large terminal on the motor start solenoid to the positive terminal on the battery with a #0 gauge battery cable. Connect the negative terminal on the battery to one of the mounting screws on the power unit using a #0 gauge battery cable, or equivalent size ground strap. See Figure 10.

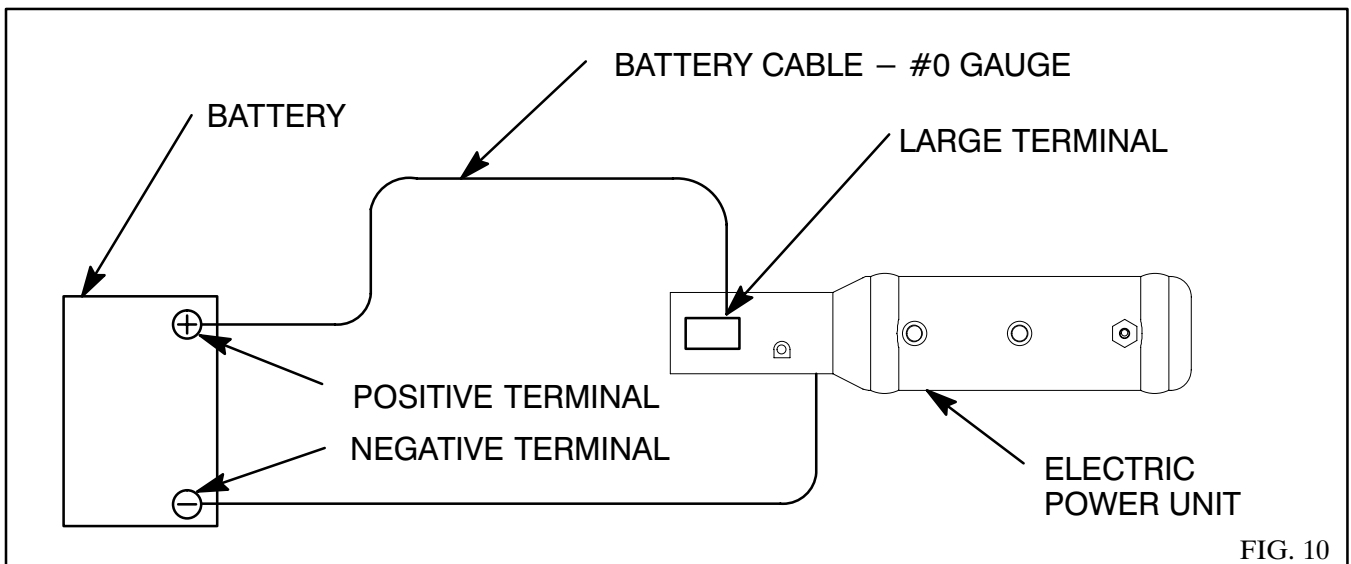

Locate the push-button control in the cab and route the cable out of the cab through a hole in the back of the cab. Connect the push-button control to the electric power unit using the 3-pin connector set.

## **INSTALL HOSES – ELECTRIC SINGLE–ACTING**

Install a 3/8 NPT x 3/4–16 JIC male elbow in the power port on the electric power unit and install a 1/4 NPT x 3/4–16 JIC male elbow in the port on the top of the reservoir.

Connect the shorter 3/8” hose from the power port on the electric power unit to the base end port on the cylinder; connect the longer 3/8” hose from the reservoir port to the rod end port. See Figure 8 for port identification. This will raise the hoist when the ‘UP’ button is pushed and lower it when the ‘DOWN’ button is pushed.

## **INSTALL HOSES – ELECTRIC DOUBLE–ACTING**

Install 9/16 ORB x 3/4 JIC 90° swivel adapters in both work ports on the electric power unit. If needed, for good hose routing, install 3/4 JIC x 3/4 JIC 90° swivel adapters to both of these adapters. Connect the shorter 3/8 ID hose with 3/4 JIC fittings from the ‘C1’ port on the electric power unit to the base end port on the cylinder. Connect the longer 3/8” ID hose with 3/4 JIC fittings from the ‘C2’ port to the rod end port. See Figure 8 for port identification.

*NOTE: The ‘C2’ port is the power down port and has only 500 PSI maximum pressure.*

## **ADD AUTOMATIC TRANSMISSION FLUID**

Initially fill the reservoir with 7 quarts of DEXRON II automatic transmission fluid. **DO NOT OVERFILL THE RESERVOIR!** Raise and lower the hoist several times and check the fluid level in the reservoir. Add fluid as needed.

## **INSTALL GREASE ZERKS AND LUBRICATE**

Install grease zerks in the body props. Lubricate all fittings at regular intervals, at least every 150 cycles or every two months. The grease fittings are located as follows:

- A. Lower Crosstube . . . . . 2 fittings
- B. Upper Crosstube . . . . . 1 fittings
- C. Cylinder Base Pivot Tube . . . . . 1 fitting
- D. Body Prop . . . . . 1 fitting
- E. Hoist Pivot Tube . . . . . 1 fitting
- F. Trip Lever – Side Pivot . . . . . 1 fitting
- G. Trip Lever – Rear Pivot . . . . . 1 fitting
- H. Side Shaft Pivot (dump through side) . . . . . 3 fittings
- I. . Side Hook Pivot (dump through side) . . . . . 2 fittings
- J. Tailgate Lower Pin . . . . . 2 fittings
- K. Tailgate Upper Hinge . . . . . 2 fittings
- L. Rear Latch Cross Shaft . . . . . 2 fittings
- M. Side Hinge Pivot (fold down side) . . . . . 3 fittings
- N. Side Shaft Pivot (fold down side) . . . . . 3 fittings

## INSTALL LIGHTS, REFLECTORS AND DECALS

Install the wiring harness on the body. Anchor the wiring harness to the wire hangers on the body and the subframe. Be sure to leave a 20 inch long loop between the anchor point on the body and the anchor point on the subframe to allow for the body to be dumped to the side and the rear without damaging the wiring harness. There should be some slack in the 20 inch loop when the body is fully raised. Raise the body fully to the side and check the wiring harness. Raise the body fully to the rear and check the wiring harness again. Splice the free end of the wiring harness into the marker and ground circuits in the truck wiring.

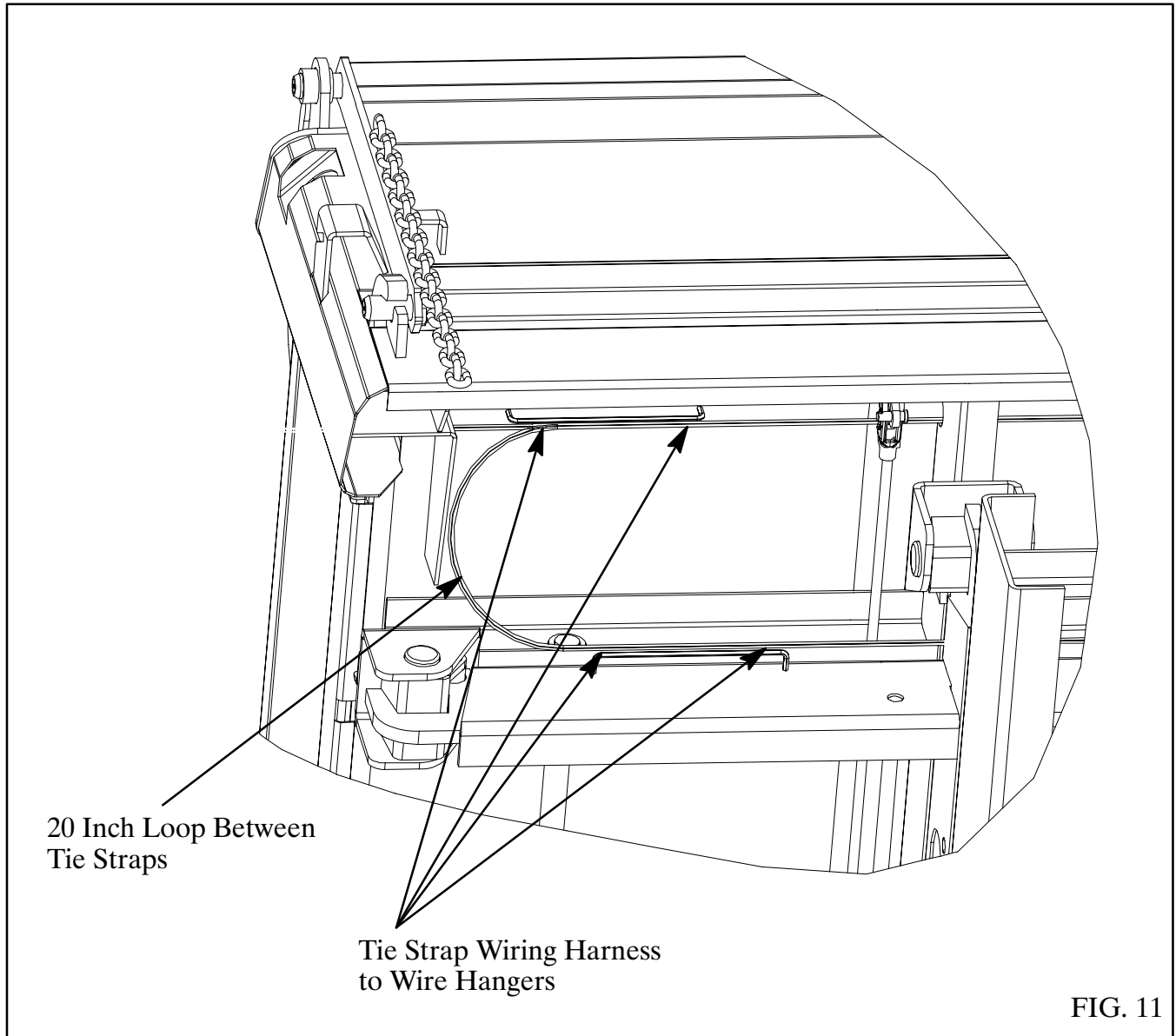

Insert marker lights into rubber grommets, connect the plugs on the wiring harness to the marker lights and mount the rubber grommets in the holes provided in the rear pillars and the rear rubrail.

Mount the amber reflectors near the front on the sides. Mount the red reflectors near the rear on the sides and on the tailgate near the sides. Slip the rubber hand grip over the end of the latch control lever. MOUNT DECALS IN THE PROPER PLACES. See Fig. 12 for decal identification and placement.

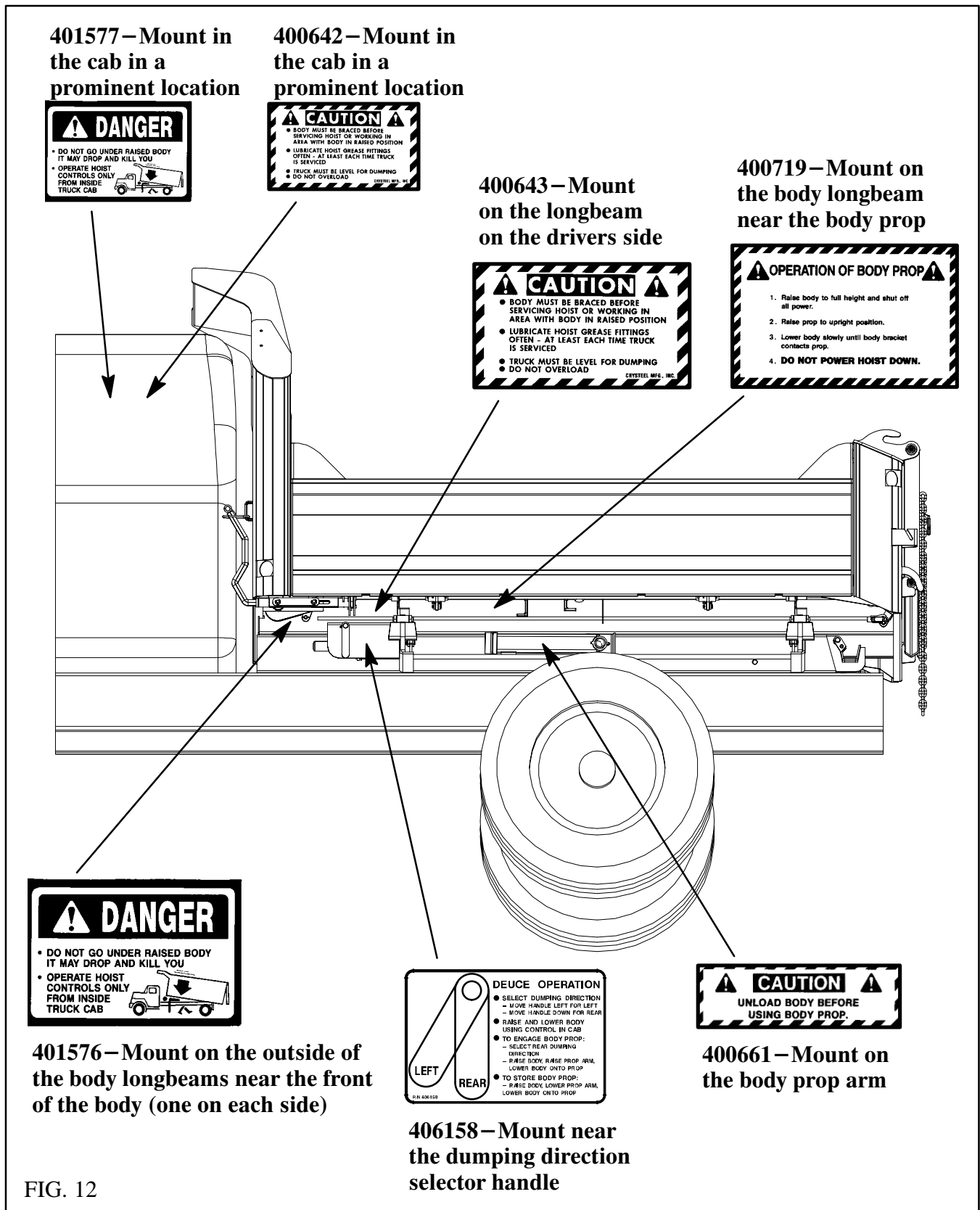
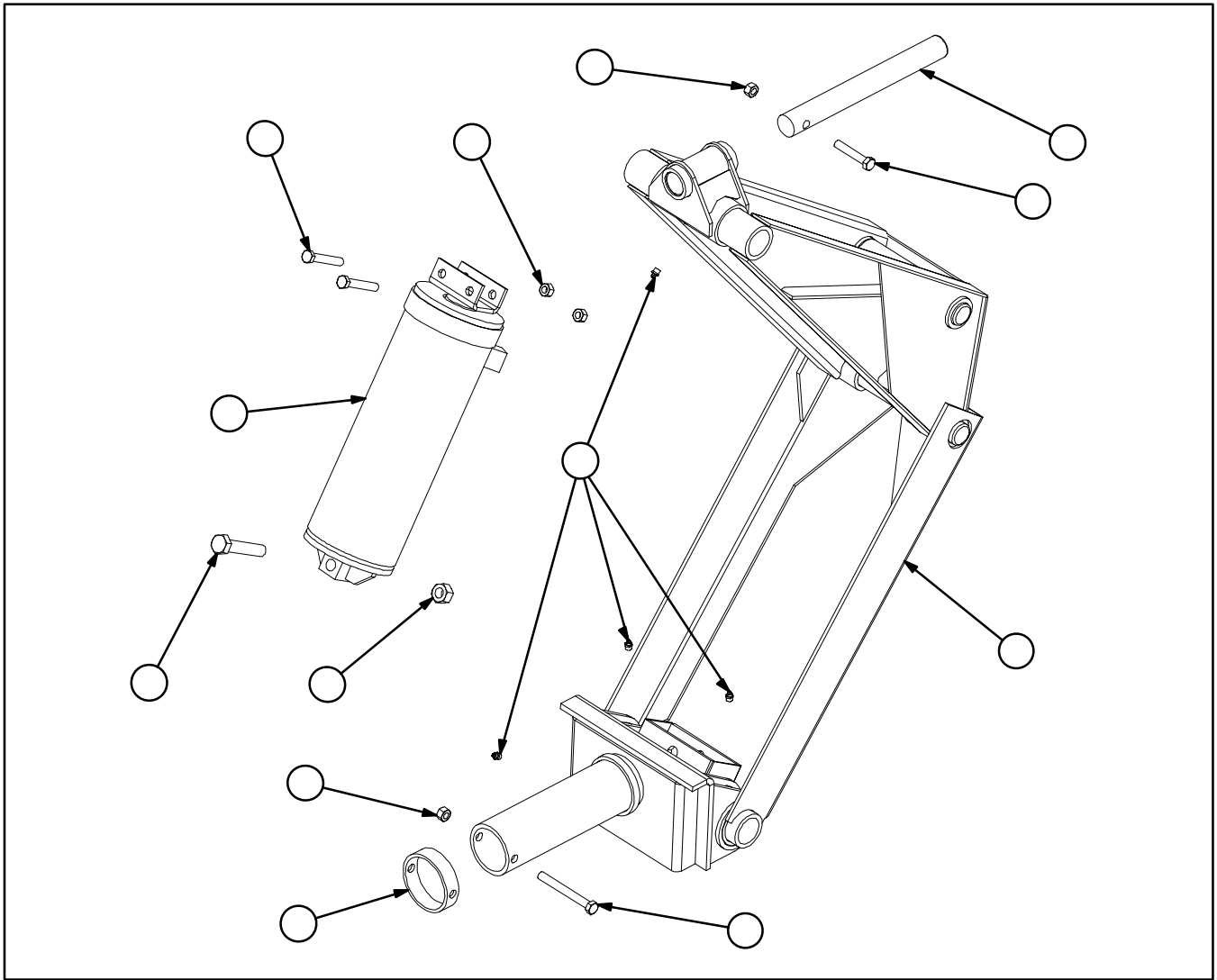

FIG. 12







		!	
!	"#\$%	&' '&	
	( ) * & + '	& !	
&	, + - . / 0 * &	& !!1	
	( ) *! + * &	& &	!
1	, + - . / 0 *!	& 1	&
	2 / *'	&	&
'	( ) *! + & *! '	&	
3	. "" , # 0 . \$ 0 4	! 1	
	( ) *! +! * & '	& & & ! 1	
	# \$ 5 ( ( # 6.0	!!!'	

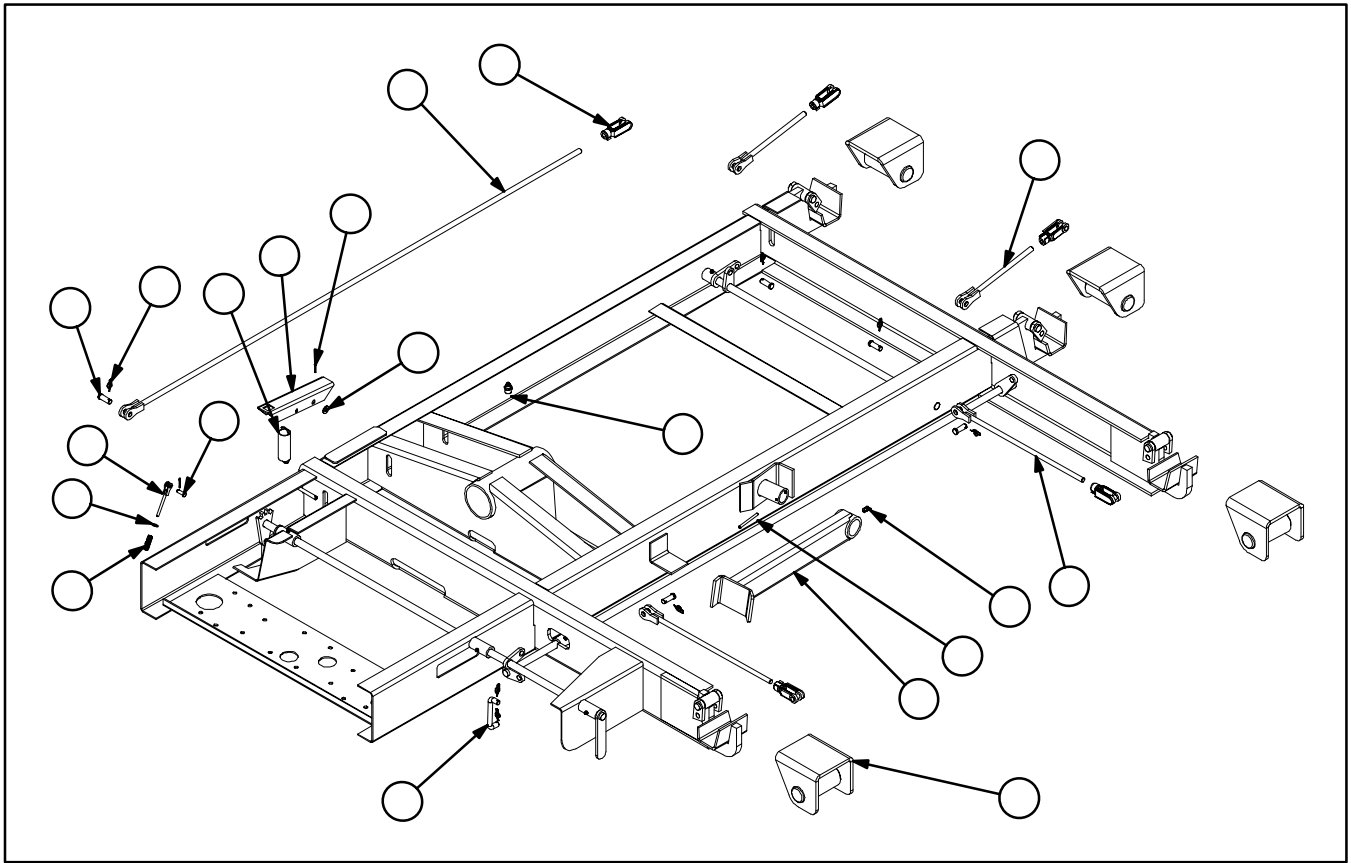

		!	"
#	\$% &%' &(	# "	
	'& ) *	##	
	& + &, )- ./	!	
	&' %	!"	#
"	&' % &	!	#
!	%, )#* 0) 1%2,	" /	
-	&' % & 1 ,	"	
/	%33 & )#* )	--/	#
	4 5 62 3 &5%2,	#!//	
	*3 % '& . ) * )# 1	--	
#	5 3 7 4 & )-	"	
	6 )#	"	!
	5 8 )#* #	#	
	5 8 )"* !)-	""	
"	6 %	""	
!	5 3 7 4 & )	-	
-	%('& % '& . - *	"	
/	% . 5)	#!" !-	
#	& + &, )-		
#	69:& ( 62 . %('5 3 ; 3 ( # 34&6 # <	!!	



39.	Electric Pump – SA	405286	1
40.	Control Push–Button – Electric Pump 10’	405289	1
	Control Push–Button – Electric Pump 15’	405290	
41.	Rubber Pad 3 x 5	405319	1
42.	Cable Tie 33”	404956	1
43.	Adapter 3/4 JICM x 1/4 NPTM 90°	402510	1
44.	Breather Cap w/ Dipstick	405384	1
45.	Adapter 3/4 JICM x 3/8 NPTM Long 90°	402509	1
46.	Assy Pump Mounting Angle	100174	2
47.	Adapter 3/4 JICM x 3/4 JICF 90°	403448	2
48.	Adapter 9/16 ORBM x 3/4 JICM 90°	403447	2

### SPECIFICATIONS

Hoist Model	Cylinder Bore	Cylinder Stroke	Cylinder Shaft	Operating Pressure
DEUCE	5 1/2”	12 1/8”	2”	3250 PSI

### CAPACITY

Body Length	Overhang	Dump Angle Rear	Capacity Rear	Dump Angle Side	Capacity Side
9’	9”	46°	10.9 Tons	55°	9.6 Tons
11’	9”	46°	8.6 Tons	55°	9.6 Tons

## NOTES

---

## *SPECIALLY DESIGNED – WITH QUALITY IN MIND*

### **WARRANTY**

- Crysteel Manufacturing, Inc. warrants its products for a period of five (5) years from date of purchase.
- This warranty covers our products for defective material and/or workmanship at a rate of 100% for the first (3) years and at a rate of 50% for years (4) and (5).
- This warranty is all encompassing and covers all areas of our product including: Crysteel manufactured product, OEM products purchased by Crysteel, the repair of the warranted product, the replacement of warranted product, the labor to replace the warranted product, and both in and outbound freight for the replacement of the warranted product. This warranty is limited to products supplied under the Crysteel Mfg. name and does not cover distributor modifications. Primer warranty is limited to adherence to metal surfaces only and does not include the inside or understructure of the dump body or hoist.
- We will not assume responsibility for travel, loss of use, or downtime expenses.
- This warranty is void if the product has been obviously abused, or subjected to usage it was not designed for.
- Please contact your Crysteel Distributor for additional details.

### **! CAUTION !**

- **BODY MUST BE BRACED BEFORE SERVICING HOIST OR WORKING IN AREA WITH BODY IN RAISED POSITION**
- **LUBRICATE HOIST GREASE FITTINGS OFTEN – AT LEAST EACH TIME TRUCK IS SERVICED**
- **TRUCK MUST BE LEVEL FOR DUMPING**
- **DO NOT OVERLOAD**

CRYSTEEL MFG, INC.

## **CRYSTEEL MANUFACTURING, INC.**

P.O. Box 178 52182 Ember Road  
Lake Crystal, MN 56055

1902 Route 57 South  
Fulton, NY 13069

(507) 726-2728 (800) 533-0494