

CRYSTEEL'S



SINGLE-ACTING TRAILER HOIST



P.O. Box 178
52182 Ember Road
Lake Crystal, MN 56055

www.colthoists.com
colthoist@crysteel.com
(507) 726-2728 (800) 533-0494

1902 Route 57 South
Fulton, NY 13069

DATE PURCHASED _____
HOIST SERIAL NUMBER _____
CYLINDER SERIAL NUMBER _____
DEALER _____
ADDRESS _____
PHONE _____

FOREWORD

This manual contains the information needed for the proper installation and operation of these hoists.

These instructions are for installing and maintaining all Colt trailer scissor hoists. With proper installation, use, and regular maintenance, Crysteel's Colt trailer hoists will give many years of trouble free service.

When ordering parts, be sure to give serial number of hoist and cylinder. The serial number of the hoist is stamped into the hoist frame near the base end of the cylinder. The serial number of the cylinder is stamped on the barrel of the cylinder near the base. For future reference, copy these numbers NOW in the space provided above. Order parts by number and description as given in the parts listing in this manual.

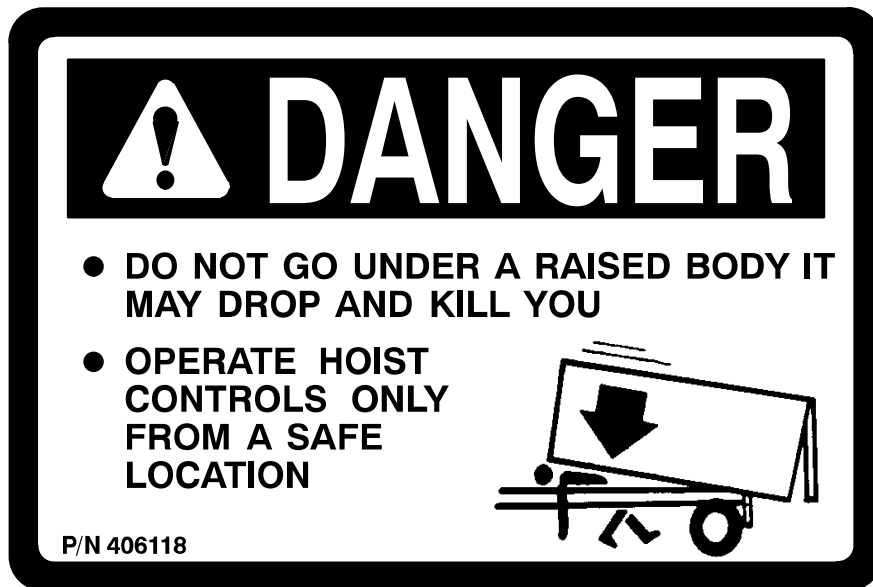

OPERATION AND USE

1. Operate hoist controls only from a safe location.
2. To raise the hoist, press and hold the 'UP' button. To hold the body in a raised position, release the 'UP' button. To lower the hoist, press and hold the 'DOWN' button.
3. Grease the hoist every 100 cycles or every two months
4. To use the body prop, raise the body, raise the body prop arm to its upright position and lower the body onto the body prop arm.
5. To lower the body prop, raise the body, lower the body prop arm to its storage position and lower the body.
6. The fluid in the electric power unit should be changed annually. Use automatic transmission fluid (Dexron II or equivalent) Clean the breather cap each time the fluid is changed.

SOME DO'S AND DON'TS FOR SAFE AND LONG SERVICE

1. Use the proper hydraulic fluid. **KEEP IT CLEAN.** Remember to change it regularly.
2. Lubricate all grease fittings at regular intervals.
3. **ALWAYS** carefully block up the body, using the body prop, before working under it.
4. Do not load the hoist beyond its capacity.
5. **DO NOT** tamper with the hydraulic relief valve. This will void the warranty. It can cause severe damage to the hoist and cylinder.
6. Check all bolts and fittings regularly. **Keep them tight.**

TABLE OF CONTENTS

Purchase Record	1
Foreword	1
Operation and Use	2
Some Do's and Don't's	2
Table of Contents	3
Hoist Mounting Methods	4
Locate and Mount Hoist – TR3, TR5, & TR8	5
Locate and Mount Hoist – TR10 & TR15	5
Locate and Mount Hoist – TR18	6
Two–Crossmember Mounting	7
Install Rear Hinge	7–8
Mount Electric Power Unit	8
Connect Hoses	9–10
Add Automatic Transmission Fluid	10
Install Body	11
Down Speed	11
Install Body Guides	11
Install Body Prop	12
Install Grease Zerks and Lubricate	13
Install Decals	14
Parts Lists and Diagrams	15–22
Specifications	23
Capacity Formula	23

INSTALLATION INSTRUCTIONS

HOIST MOUNTING METHODS

The following illustrations show three methods of trailer frame construction for mounting the hoist frame and cylinder.

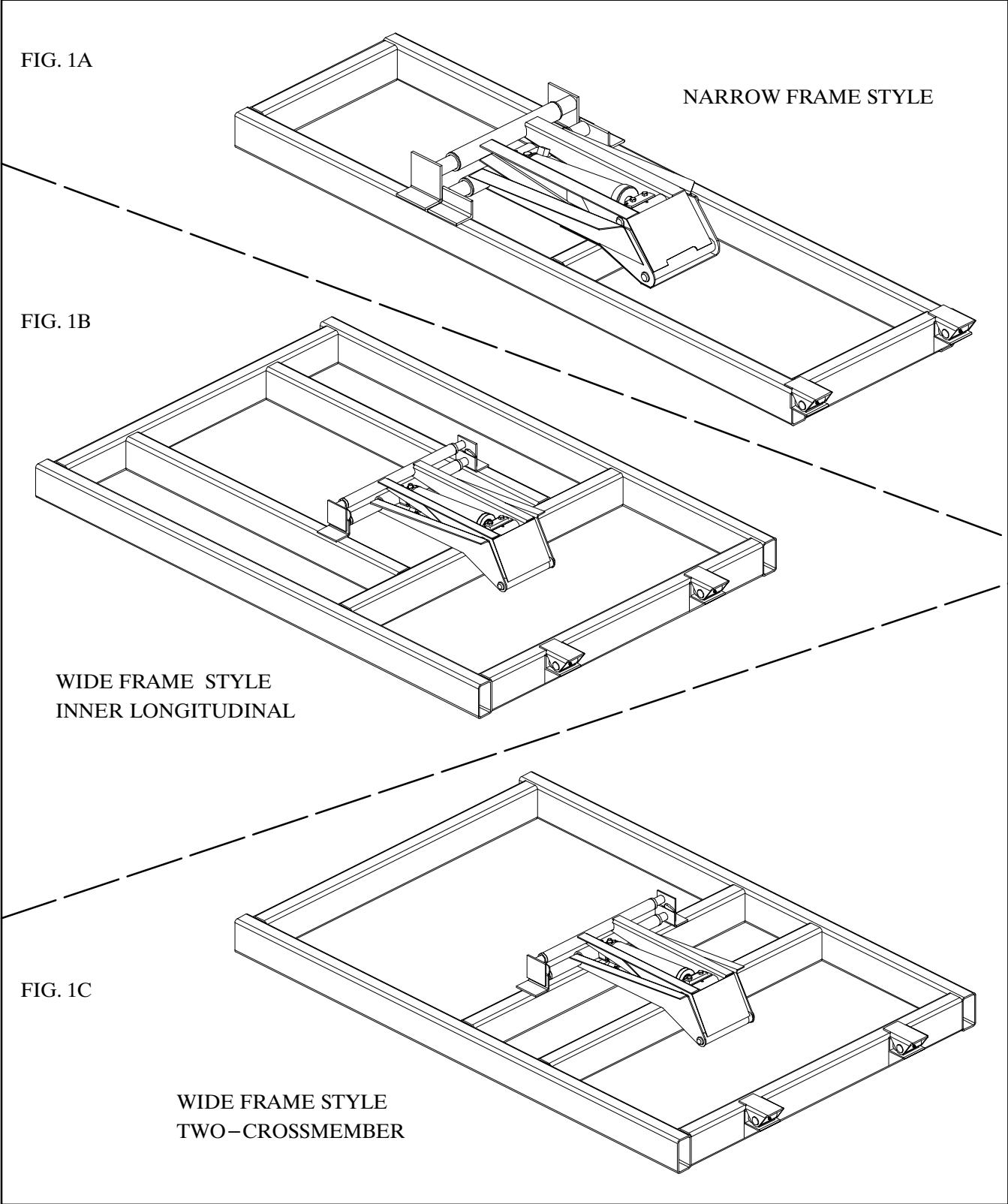

LOCATE AND MOUNT HOIST – MODELS TR3, TR5 & TR8

Determine where to mount the hoist on the trailer. Please refer to the chart in Fig. 2 for the relationship between dump angle and “D” dimension. Measure forward from the center of the rear hinge pin and mark, on the trailer frame, the location of the front crosstube of the hoist frame. Place the hoist on the trailer frame and clamp the hoist pivot pads to the trailer frame. The hoist should be level with the trailer frame. The back end of the hoist must be supported by a crossmember in the trailer frame. The “CM” dimension shows the location for this crossmember. Make sure the hoist frame is centered on and square with the trailer frame. Securely weld the lower hoist pivot pads to the trailer frame. Remove the clamps.

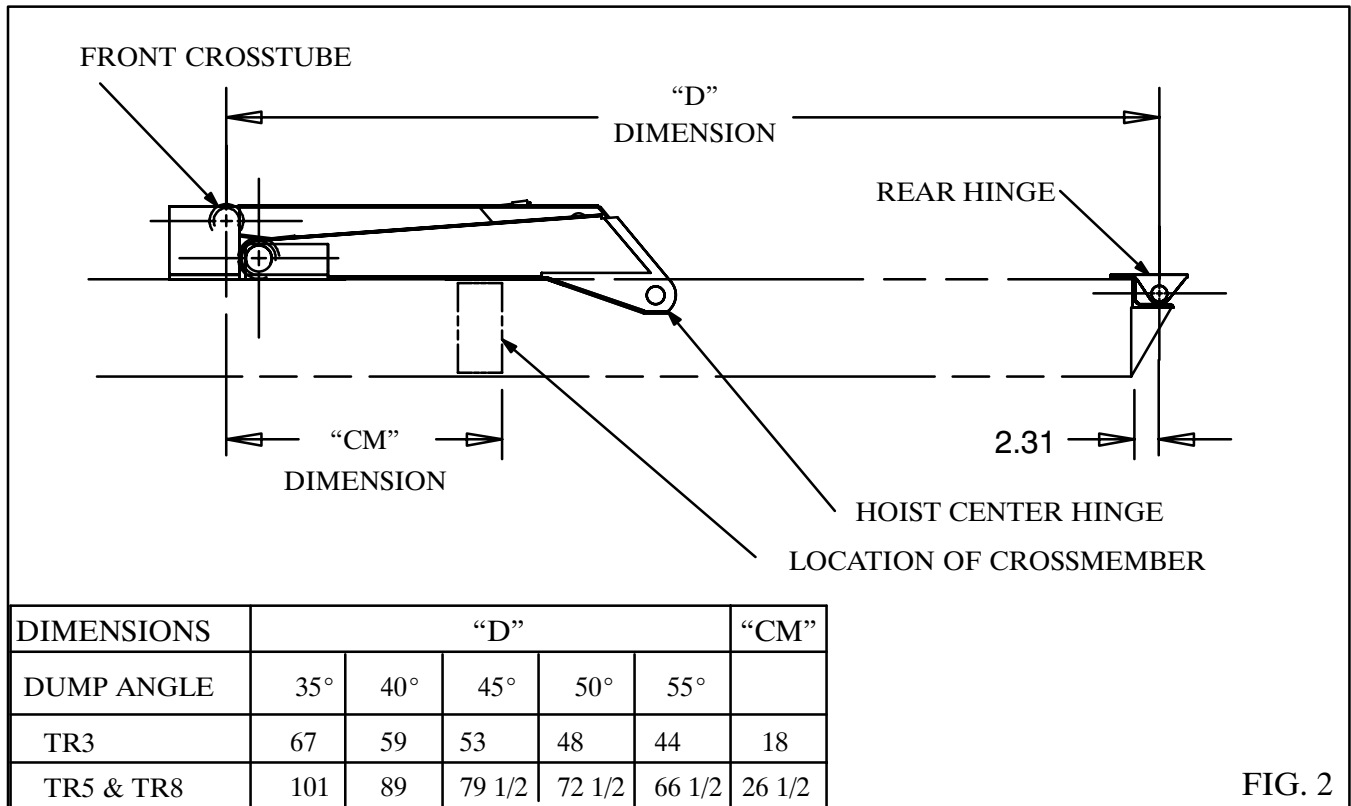

FIG. 2

LOCATE AND MOUNT HOIST – MODELS TR10 & TR15

Determine where to mount the hoist on the trailer. Please refer to the chart in Fig. 3 for the relationship between dump angle and “D” dimension. Measure forward from the center of the rear hinge pin and mark, on the trailer frame, the location of the front crosstube of the hoist frame. Place the hoist on the trailer frame and clamp the hoist pivot pads to the trailer frame. The hoist should be level with the trailer frame. The back end of the hoist must be supported by a crossmember in the trailer frame. The “CM” dimension shows the location for this crossmember. Make sure the hoist frame is centered on and square with the trailer frame. Securely weld the lower hoist pivot pads to the trailer frame. Remove the clamps.

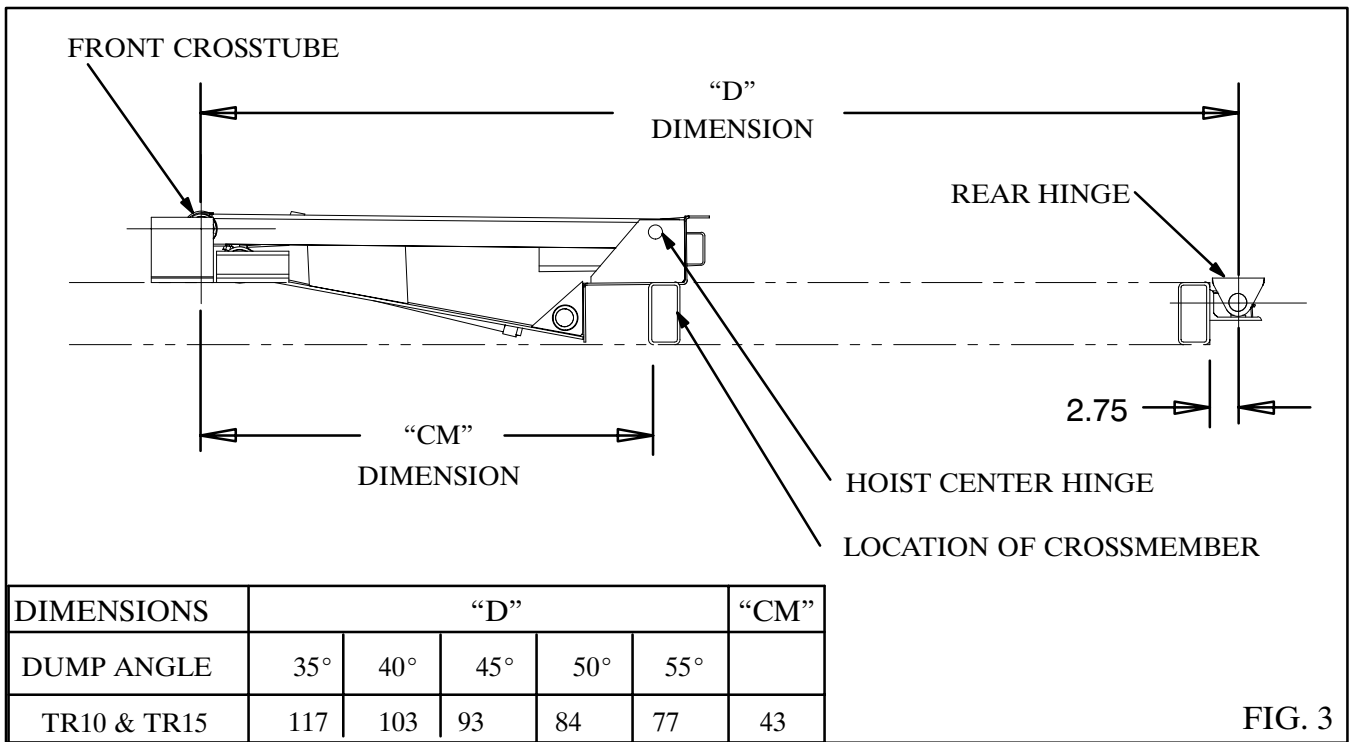

FIG. 3

LOCATE AND MOUNT HOIST – MODELS TR18

Determine where to mount the hoist on the trailer. Please refer to the chart in Fig. 4 for the relationship between dump angle and "D" dimension. Measure forward from the center of the rear hinge pin and mark, on the trailer frame, the location of the front crosstube of the hoist frame. Place the hoist on the trailer frame and clamp the hoist pivot pads to the trailer frame. The hoist should be level with the trailer frame. The back end of the hoist must be supported by a crossmember in the trailer frame. The "CM" dimension shows the location for this crossmember. Make sure the hoist frame is centered on and square with the trailer frame. Securely weld the lower hoist pivot pads to the trailer frame. Remove the clamps.

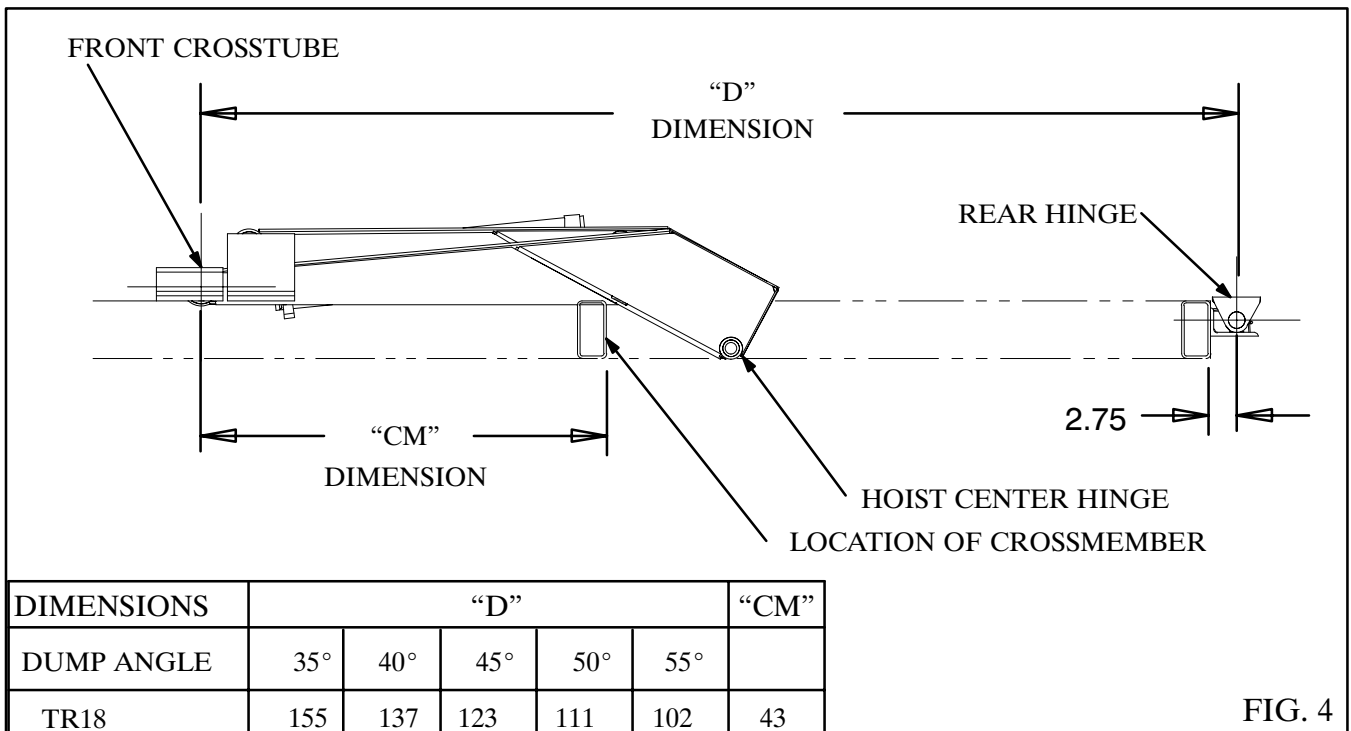
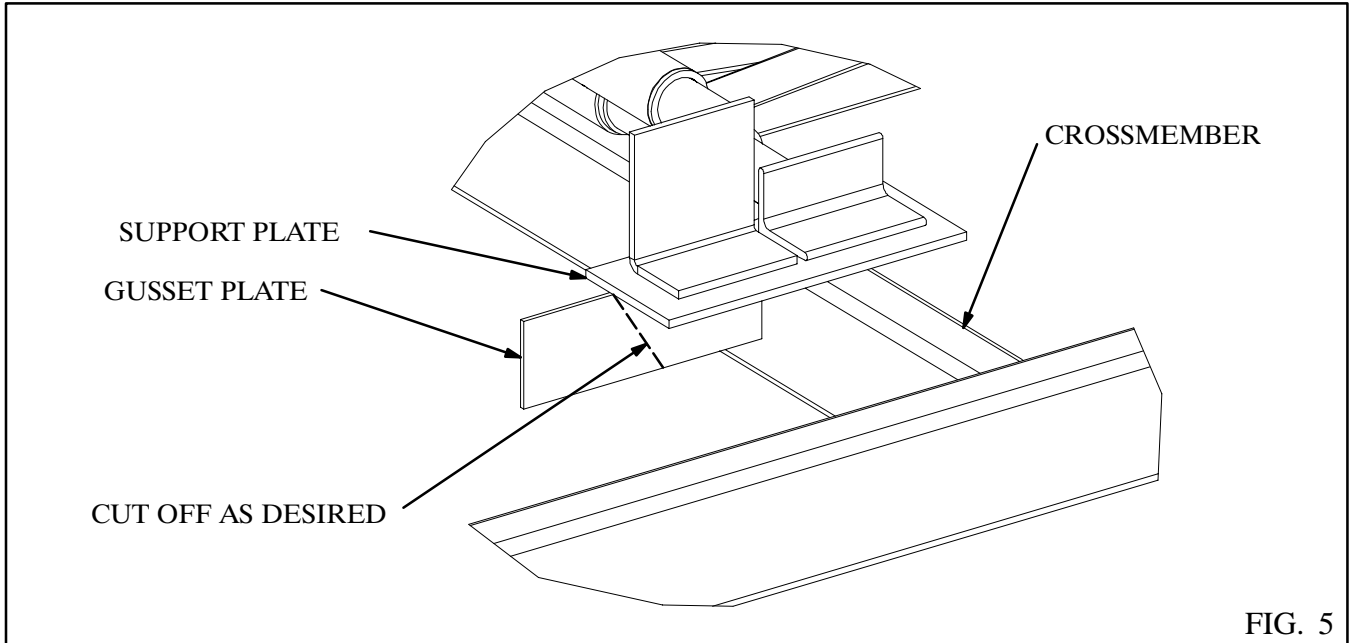

FIG. 4

TWO-CROSSMEMBER MOUNTING

It is important that both upper and lower mounting angles on the hoist frame be supported. For the narrow and inner longitudinal frame versions (Figures 1A & 1B), both angles rest on the longitudinals. When mounting the Colt trailer hoist on a crossmember, as shown in Figure 1C, supporting plates must be used. Place the supporting plate on the crossmember and the gusset plate underneath it. Trim off the excess material of the gusset plate. See Figure 5.



INSTALL REAR HINGE

Crysteel's rear hinge pads are designed to be welded to the rear crossmember of the trailer frame as shown in Figures 6 and 7. The Colt trailer hoists and rear hinge are designed so the longbeams of the platform sit on the mounting angles of the hoist frame and on top of the rear hinge pad. When locating the rear hinge pads, be sure the top of the hinge pad is even with the top of the hoist mounting angles and that they are aligned with each other. Fully weld the rear hinge angles to the trailer frame as shown in Figures 8 & 9. Trim braces under the rear hinge angle if needed. See Figure 6.

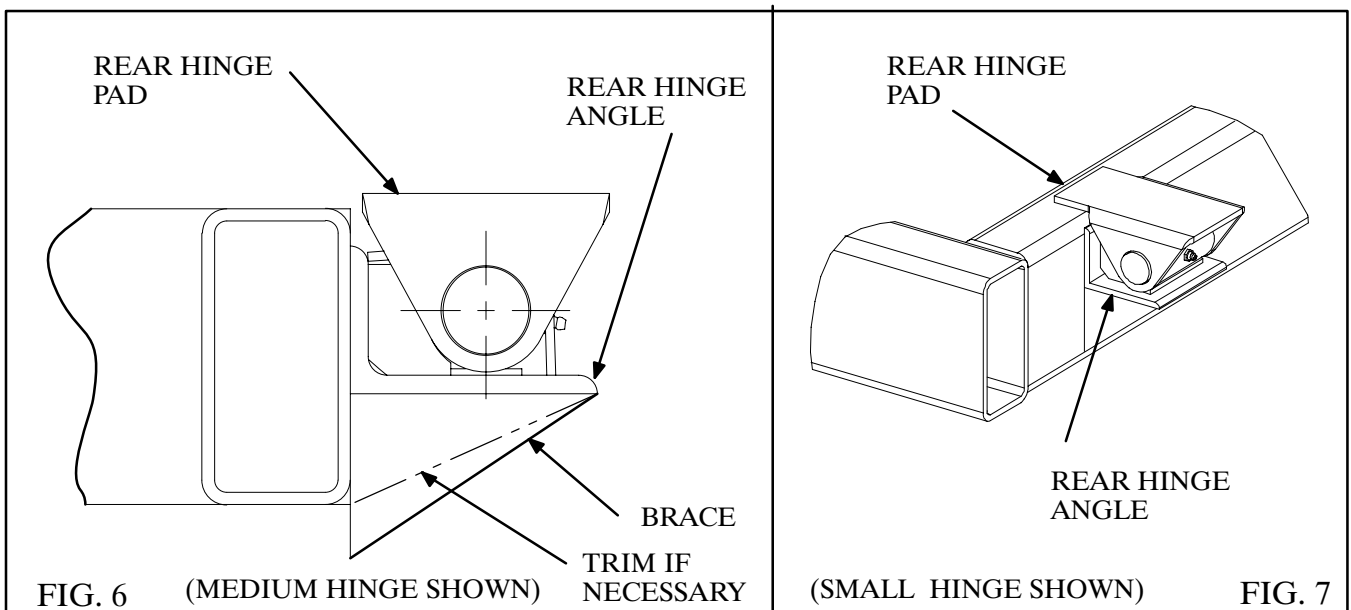

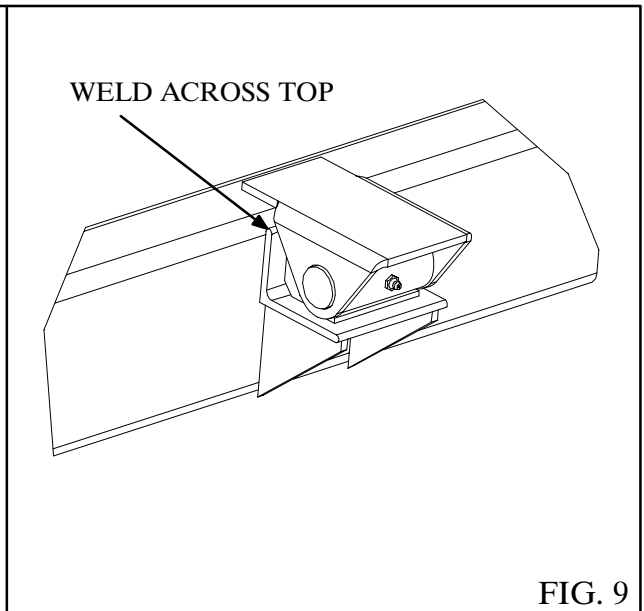
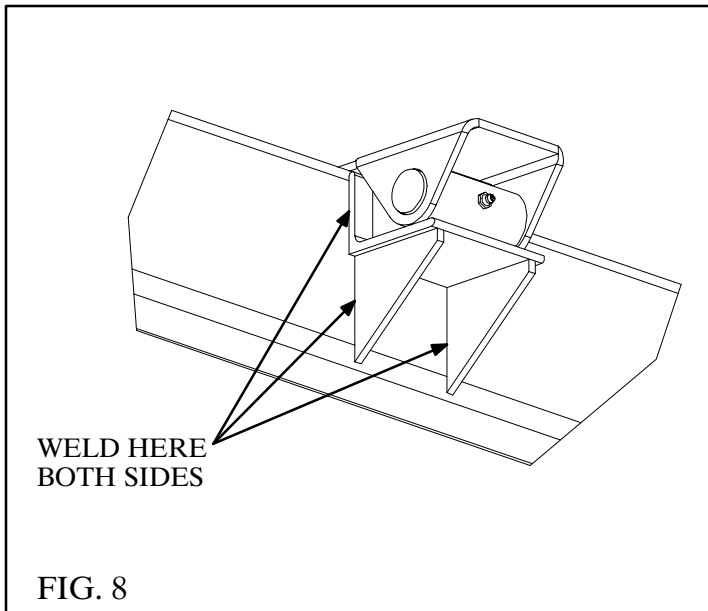

MOUNT ELECTRIC POWER UNIT

The electric power unit and the battery should be mounted in a protected area. Bolt the power unit in place using the 3/8 x 1 hex head cap screws, tightening to 24 to 26 lb–ft.

Connect the large terminal on the motor start solenoid to the positive terminal on the battery with a #0 gauge battery cable. Connect the negative terminal on the battery to one of the mounting screws on the power unit using a #0 gauge battery cable, or equivalent size ground strap.

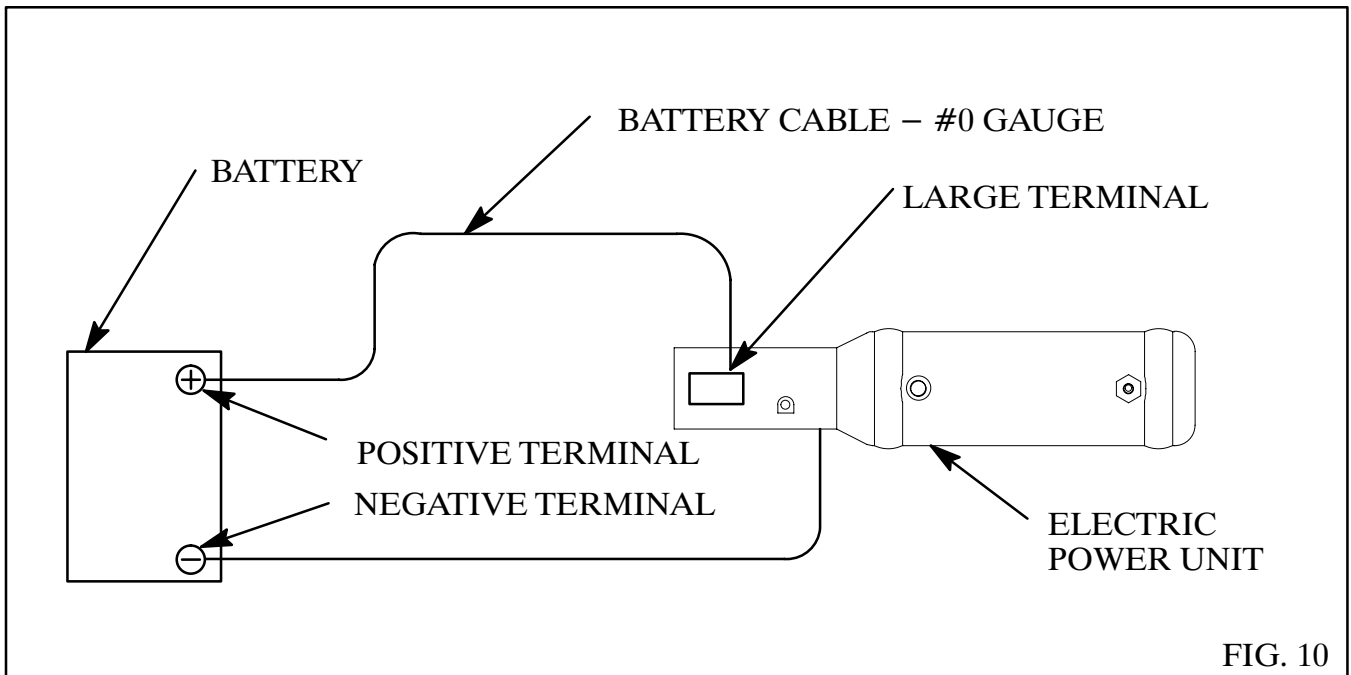

The hoist control should be operated only from a safe location. Mount the hoist control pendant in a safe location.

CONNECT HOSES

Install a 1/4 NPT x 7/16 JIC male elbow in a 3/4 x 1/4 hex bushing and install this in the port on the top of the reservoir.

For TR3, TR5 and TR8 hoist models, install a 9/16 ORB x 3/4–16 JIC male elbow in the power port on the electric power unit.

Connect a 3/8" hose (3500 psi minimum pressure rating) to the base end cylinder port on the hoist and to the flow control. Connect a 1/4" hose (250 psi minimum pressure rating) to the rod end cylinder port and to the reservoir on the electric power unit. See Figure 11.

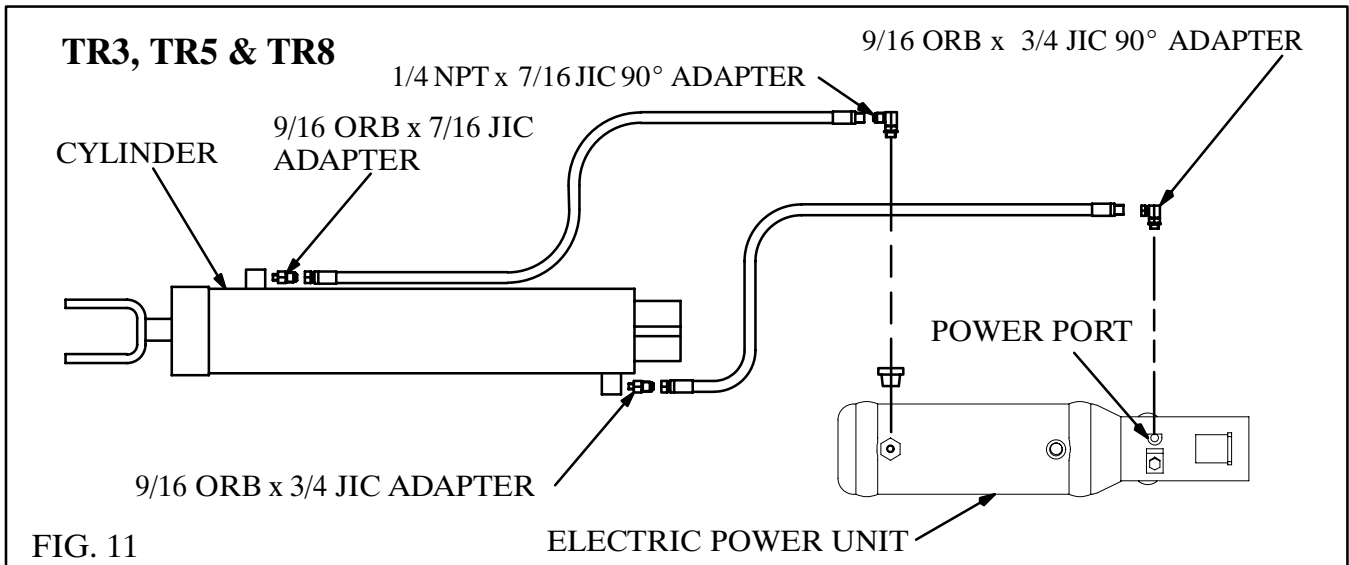

For TR10 and TR15 hoist models, install two 18" long 3/8" hoses to the cylinder ports as shown in Figure 10. Install a 9/16 ORB x 3/4–16 JIC male elbow in the power port on the electric power unit. Connect a 3/8" hose (3500 psi minimum pressure rating) to the hydraulic line assembly in the hoist frame connected to the base end cylinder port and to the power port on the electric power unit. Connect a 1/4" hose (250 psi minimum pressure rating) to the hydraulic line assembly in the hoist frame connected to the rod end cylinder port and to the reservoir on the electric power unit. See Figure 12.

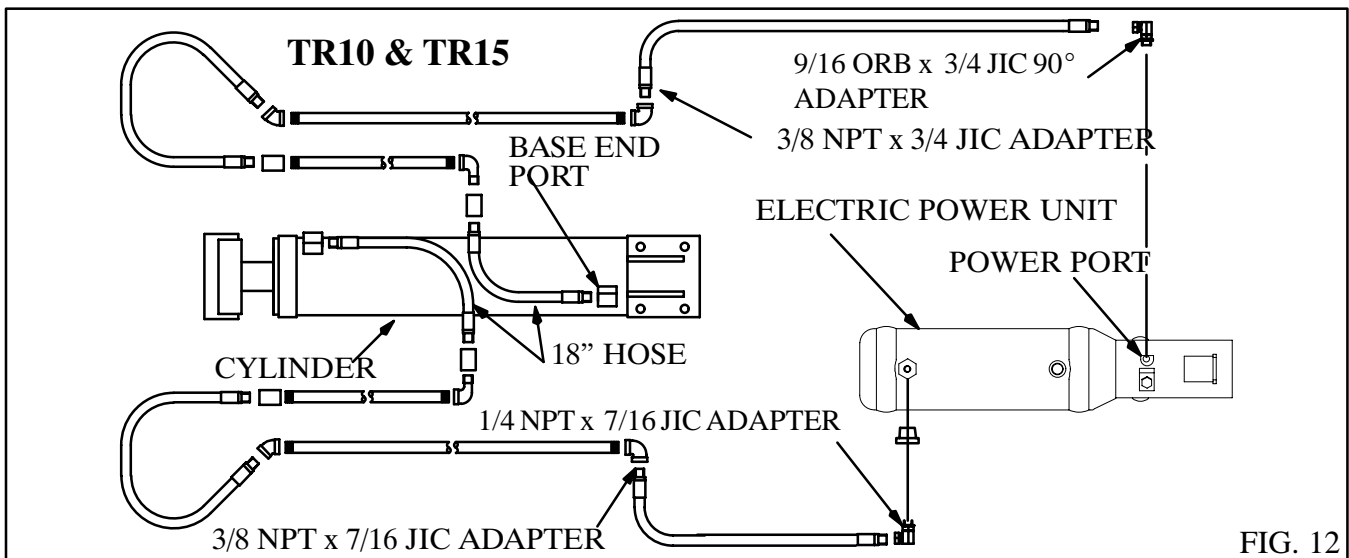

For TR18 hoist model, install a 9/16 ORB x 3/4-16 JIC male elbow in the power port on the electric power unit and connect a 3/8" hose (3500 psi minimum pressure rating) from the base end cylinder port on the hoist to the power port on the electric power unit. Connect a 1/4" hose (250 psi minimum pressure rating) to the rod end cylinder port and to the reservoir on the electric power unit. See Figure 13.

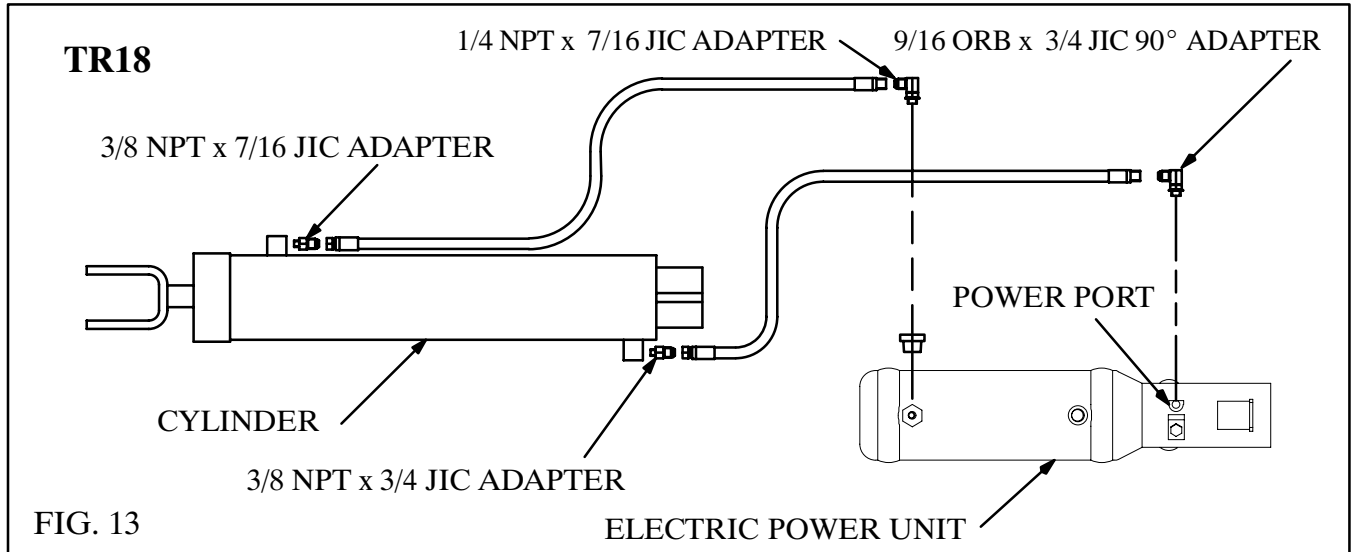

ADD AUTOMATIC TRANSMISSION FLUID

For the TR3, TR5, TR8 and TR10, add 7 quarts of DEXRON II automatic transmission fluid to the reservoir. For the TR15 and TR18, add 20 quarts of DEXRON II automatic transmission fluid. **DO NOT OVERFILL THE RESERVOIR!** Raise and lower the hoist several times and check the fluid level in the reservoir. Add fluid as needed.

KEEP THE ATF CLEAN! USE CLEAN CONTAINERS, FUNNELS AND OTHER EQUIPMENT!

With normal use and working conditions the automatic transmission fluid should be changed annually. The breather cap should be cleaned every time the automatic transmission fluid is changed. With heavy use or very dusty working conditions the automatic transmission fluid should be changed more often.

INSTALL BODY

Place the body in position on the trailer frame. Align the body longbeams carefully with the trailer frame. Securely weld the longbeams to the rear hinge pads and to the upper hoist pivot pads.

If the body has channel longbeams, weld a spacer (not supplied) to the top of the upper hoist pivot pads and to the top flange of the longbeam channels as shown in Figure 14. If the body has tubular longbeams or channel longbeams with the legs out, weld the hoist pivot pads to the inside of the inside of the longbeam as shown in Figure 15. Be sure to do this on both sides.

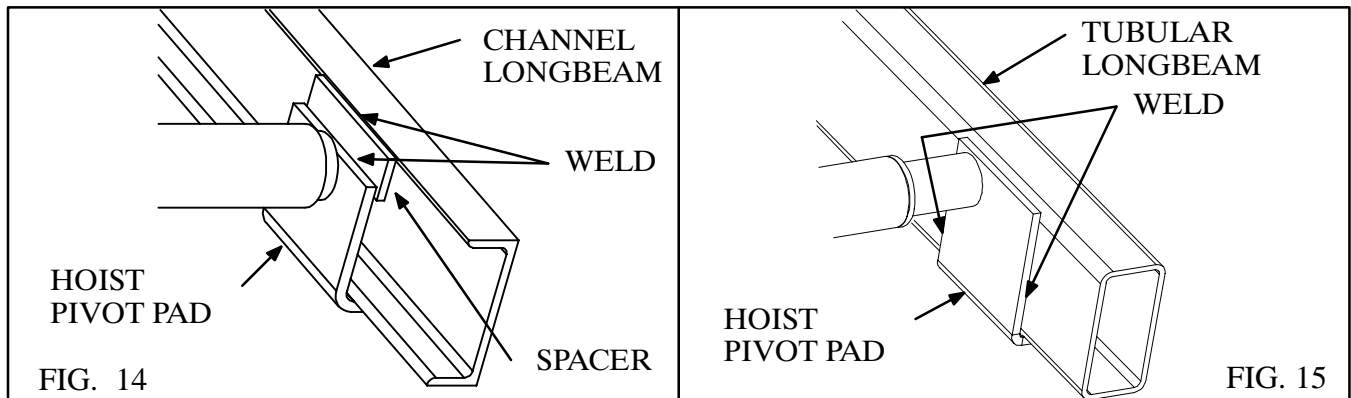

DO NOT WORK UNDER A RAISED BODY UNLESS THE BODY IS SECURELY BLOCKED OR PROPPED IN THE RAISED POSITION.

DOWN SPEED

Once the hoist is installed raise the hoist to its full stroke and time the down cycle. Crysteel Mfg. recommends a lowering time of 15 seconds or longer for an empty body (the time will vary depending on body weight and ambient temperature). If the down cycle time is less than 15 seconds, contact Crysteel to purchase an optional flow control kit. Flow control kits are available from Crysteel in different flow rates to control the down speed.

INSTALL BODY GUIDES

Crysteel recommends that guides be installed to keep the body and trailer frame aligned when the body is down.

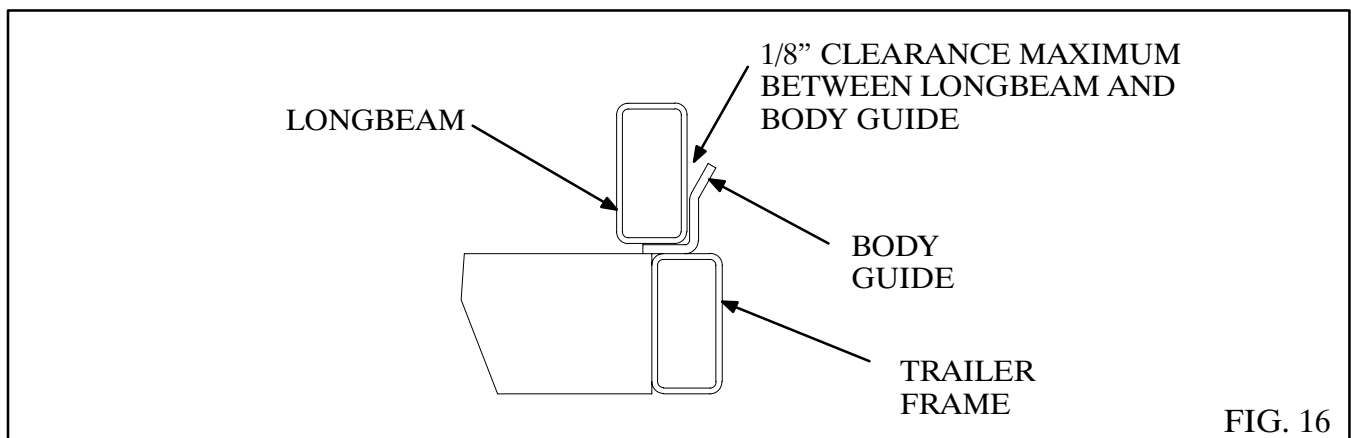

INSTALL BODY PROP

The body prop is designed and intended to support an EMPTY trailer body in the raised position. Use of the body prop permits service to be performed safely beneath a raised body. Install the prop on the trailer as explained below and shown in Fig. 17.

1. Raise the body to a 20° to 30° angle and brace it securely before beginning installation.
2. Clamp the prop pivot against the outside of the trailer frame. Raise the body prop arm to a free standing position. Reposition the prop if needed to locate the prop bracket on the longbeam. It may be necessary to raise or lower the body to get the best location for the prop pivot mount. Securely weld the prop pivot to the trailer frame.
3. A pocket needs to be constructed on the body to prevent the top end of the prop tube from sliding forward or back or from side-to-side.
4. To operate the body prop, raise the body to the desired height, raise the prop arm to a free standing position. Lower the body slowly until the body contacts the prop arm.
5. To place the body prop in the storage position, raise the body to clear the body prop, lower the body prop to the storage position and lower the body.

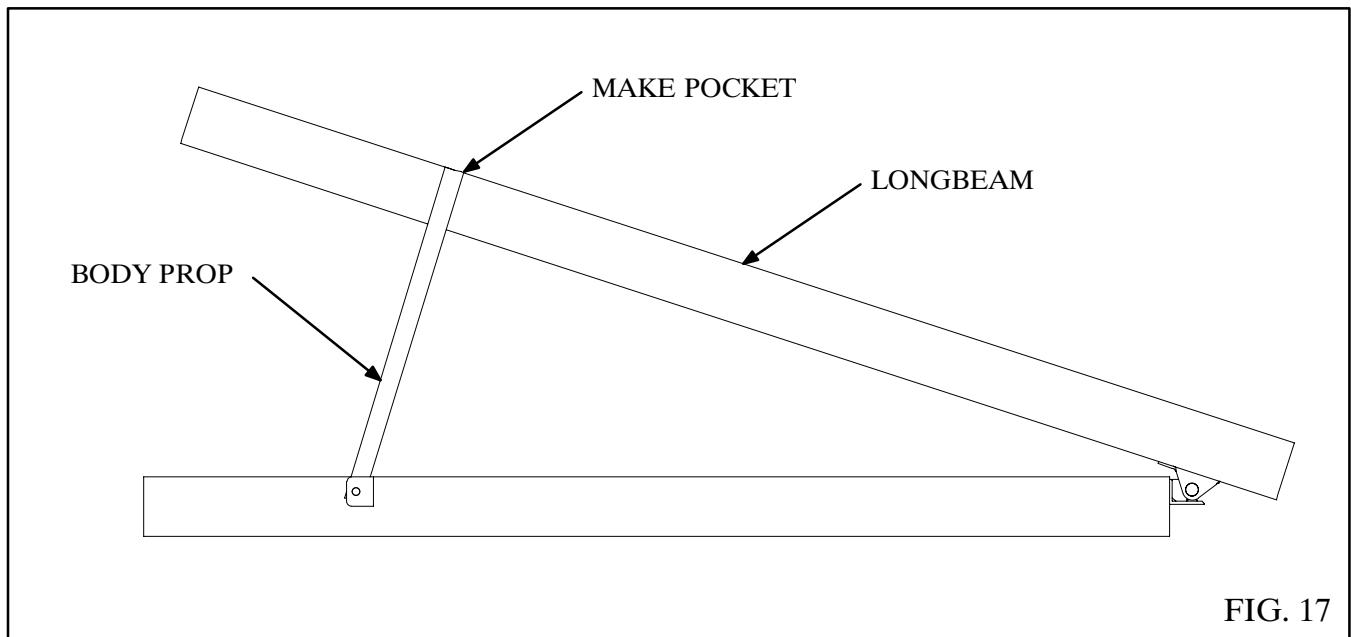

INSTALL GREASE ZERKS AND LUBRICATE

Install grease zerks in the hoist frame. Lubricate all fittings at regular intervals, at least every 100 cycles or every two months. The grease fittings are located (See Fig. 18.) as follows:

- A. Rear Hinge 2 fittings (already installed)
- B. Lower Cylinder Mount 1 fitting
- C. Lower Crosstube 2 fittings
- D. Upper Crosstube 2 fittings
- E. Cylinder Crosshead 1 fitting
- F. Center Hinge 1 or 2 fitting(s)

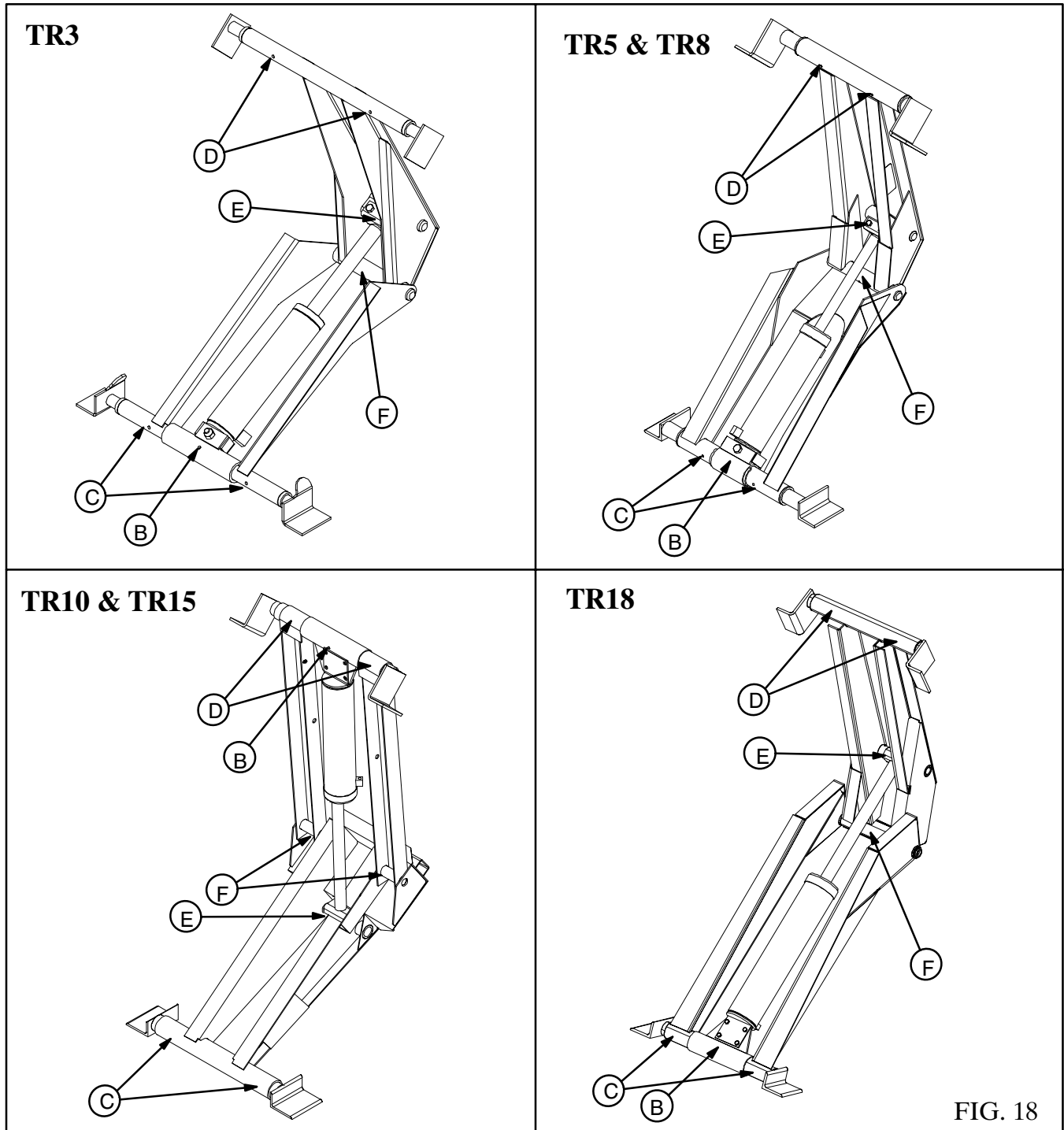
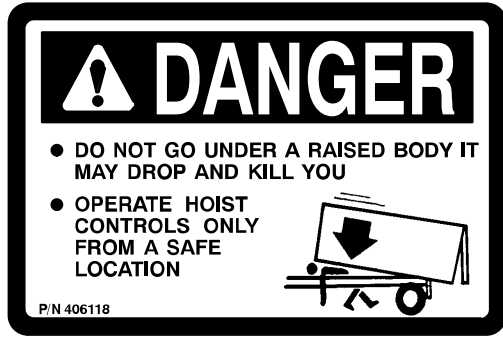

FIG. 18

INSTALL DECALS

Mount decals in the proper places as shown in Figure 19.



406118 – Mount on the outside of the body longbeams near the front of the body (one on each side)



406117 – Mount on the longbeam on the left side

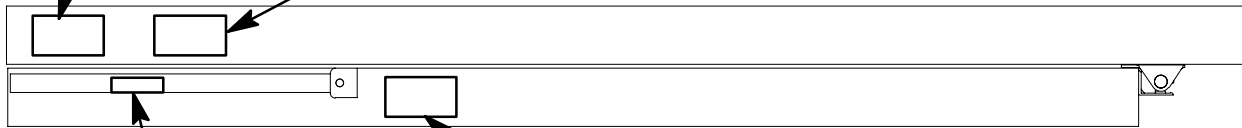

400661 – Mount on the body prop

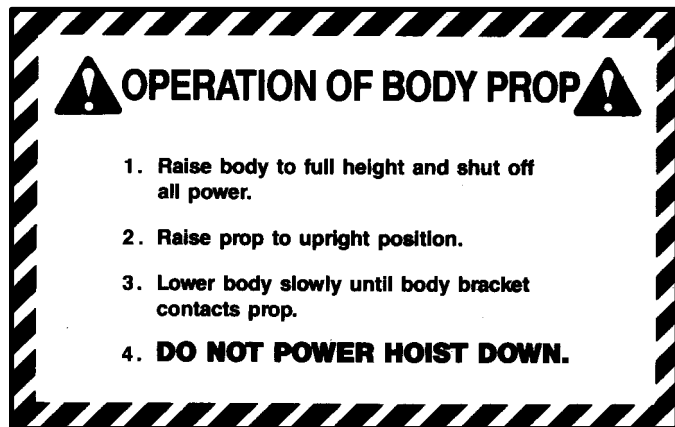

400719 – Mount on the body longbeam near the body prop

FIG. 19

TR 3 HOIST PARTS

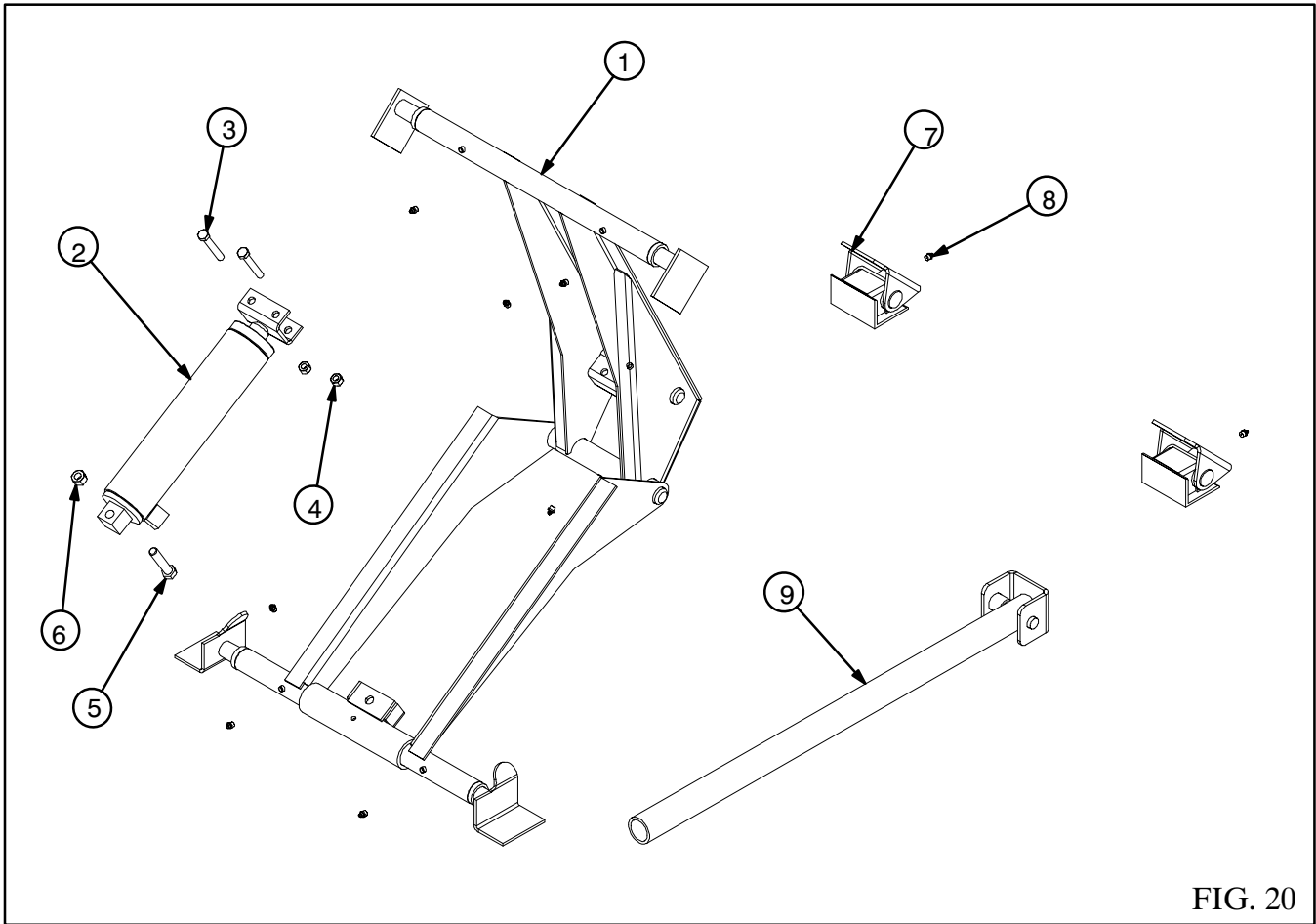

ITEM	DESCRIPTION	MODEL	PART NO.	QTY.
1.	Assy Frame	TR3	151346	1
2.	Assy Cylinder	TR3	150978	1
3.	Cap Screw 1/2-13 x 3 1/4 Gr 5	TR3	401140	2
4.	Hex Lock Nut 1/2-13	TR3	401316	2
5.	Cap Screw 5/8-11 x 3 Gr 8	TR3	406061	1
6.	Hex Lock Nut 5/8-11	TR3	401585	1
7.	Assy Rear Hinge Pad - Sm	TR3	150986	2
8.	Grease Zerk 1/8 NPT	TR3	400103	9
9.	Assy Body Prop	TR3	151451	1

TR5 & TR8 HOIST PARTS

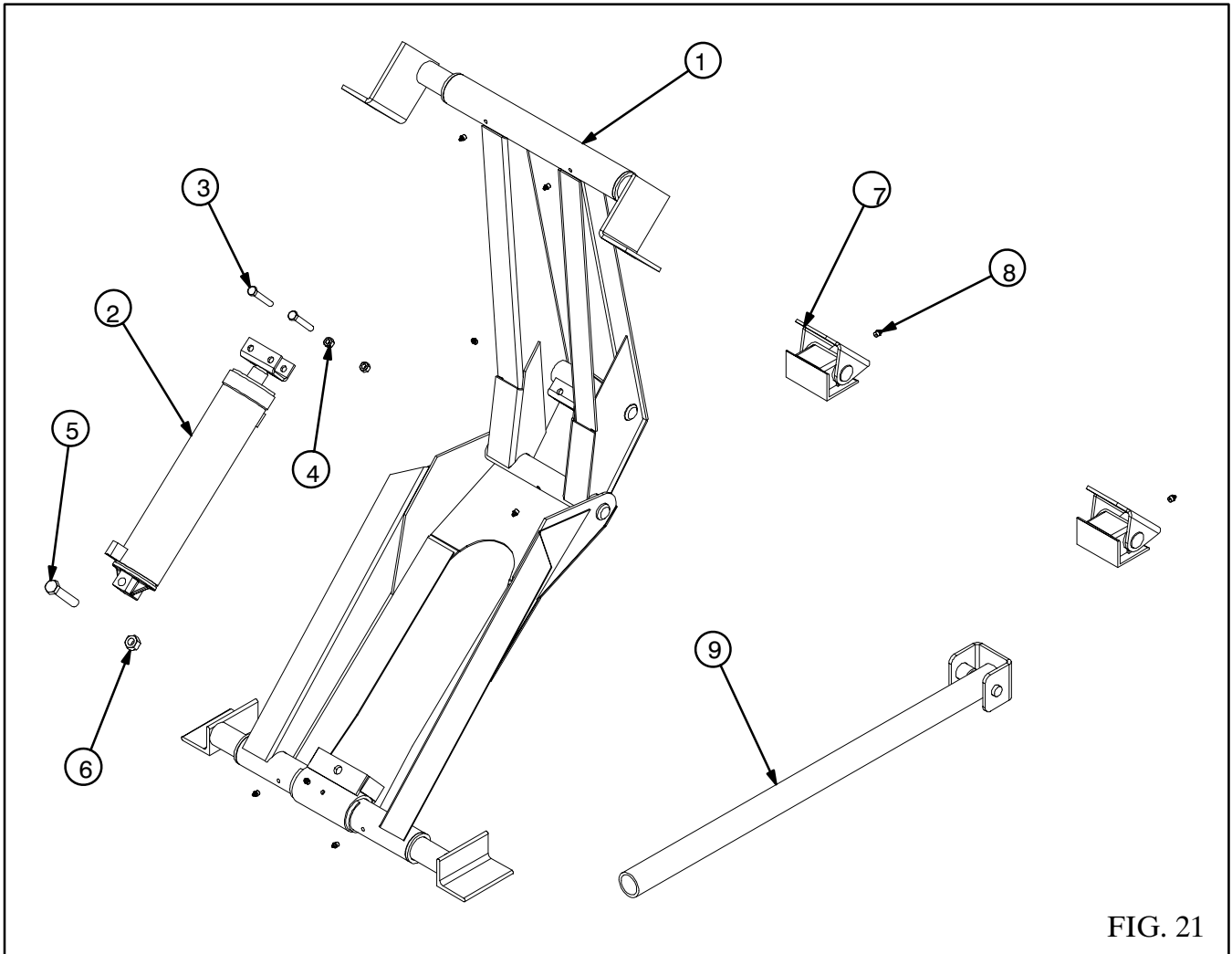
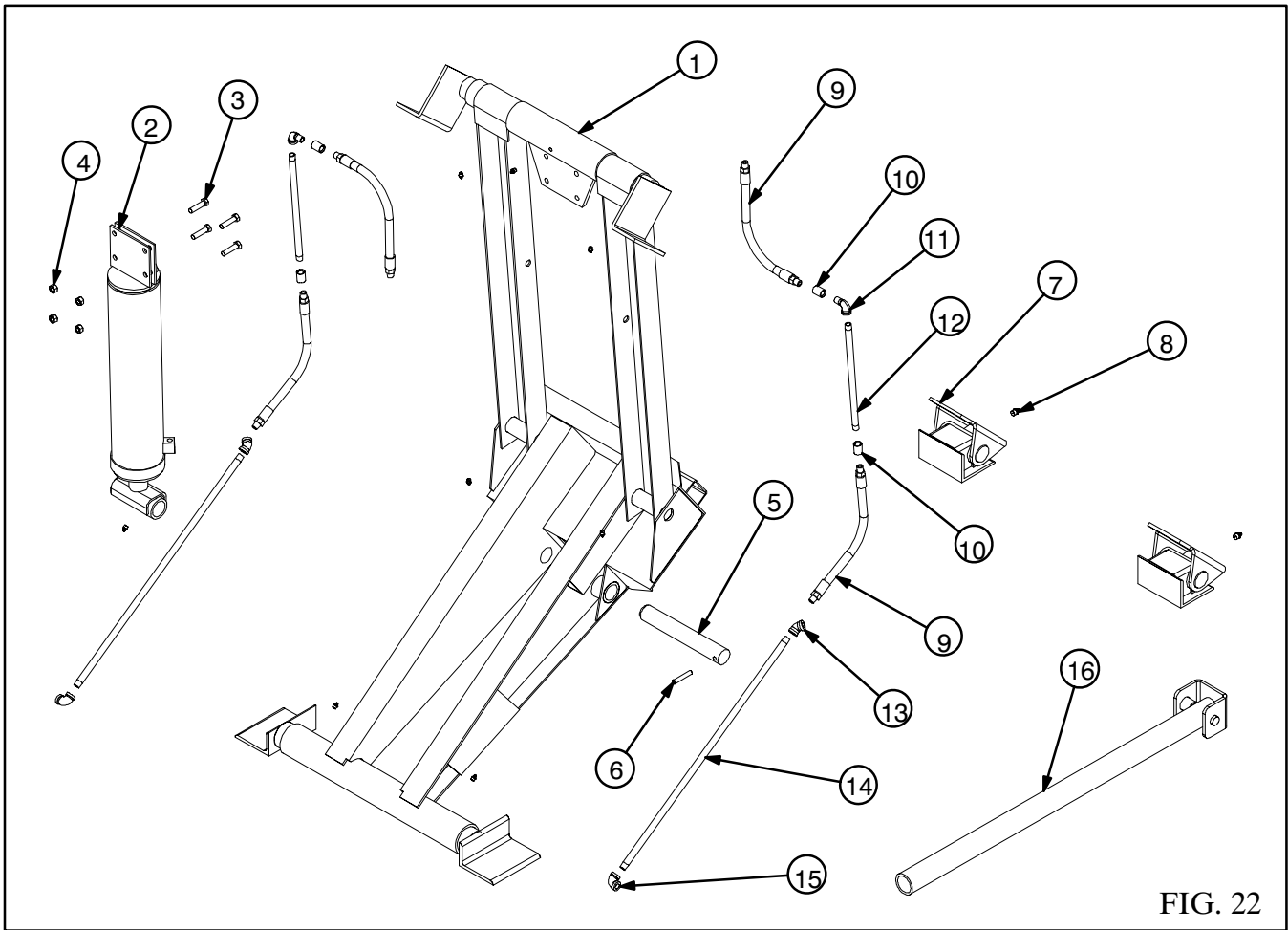

FIG. 21

ITEM	DESCRIPTION	MODEL	PART NO.	QTY.
1.	Assy Frame – TR5	TR5	151398	1
	Assy Frame – TR8	TR5	151399	1
2.	Assy Cylinder	TR8	105528	1
	Assy Cylinder	TR8	110304	1
3.	Cap Screw 1/2–13 x 3 1/4 Gr 5	TR5 & TR8	401140	2
4.	Hex Lock Nut 1/2–13	TR5 & TR8	401316	2
5.	Cap Screw 3/4–10 x Gr 8	TR5 & TR8	401237	1
6.	Hex Lock Nut 3/4–10	TR5 & TR8	401226	1
7.	Assy Rear Hinge Pad – Sm	TR5 & TR8	150986	2
8.	Grease Zerk 1/8 NPT	TR5 & TR8	400103	9
9.	Assy Body Prop	TR5 & TR8	151451	1

TR10 & TR15 HOIST PARTS



ITEM	DESCRIPTION	MODEL	PART NO.	QTY.
1.	Assy Frame – TR10	TR10	151705	1
	Assy Frame – TR15	TR15	151706	1
2.	Assy Cylinder	TR10	104235	1
	Assy Cylinder	TR15	104236	1
3.	Cap Screw 1/2–13 x 1 3/4 Gr 5	TR10 & TR15	400104	4
	Cap Screw 1/2–13 x 2 Gr 8	TR10 & TR15	400105	4
4.	Hex Lock Nut 1/2–13	TR10 & TR15	401316	4
5.	Crosshead Shaft	TR10 & TR15	201158	1
6.	Spirol Pin 7/16 x 2 1/2	TR10 & TR15	400208	1
7.	Assy Rear Hinge Pad – Med	TR10 & TR15	146157	2
8.	Grease Zerk 1/8 NPT	TR10 & TR15	400103	10
9.	Hose 3/8 NPT x 18” 4000 PSI	TR10 & TR15	400509	4
10.	Pipe Coupling 3/8 NPT	TR10 & TR15	400415	4
11.	Street Elbow 3/8 NPT	TR10 & TR15	400412	2
12.	Pipe 3/8” x 14”	TR10 & TR15	400565	2
13.	Pipe Elbow 3/8 – 45°	TR10 & TR15	400414	2
14.	Pipe 3/8” x 30”	TR10 & TR15	400567	2
15.	Pipe Elbow 3/8 – 90°	TR10 & TR15	400413	2
16.	Assy Body Prop	TR10 & TR15	151451	1

TR18 HOIST PARTS

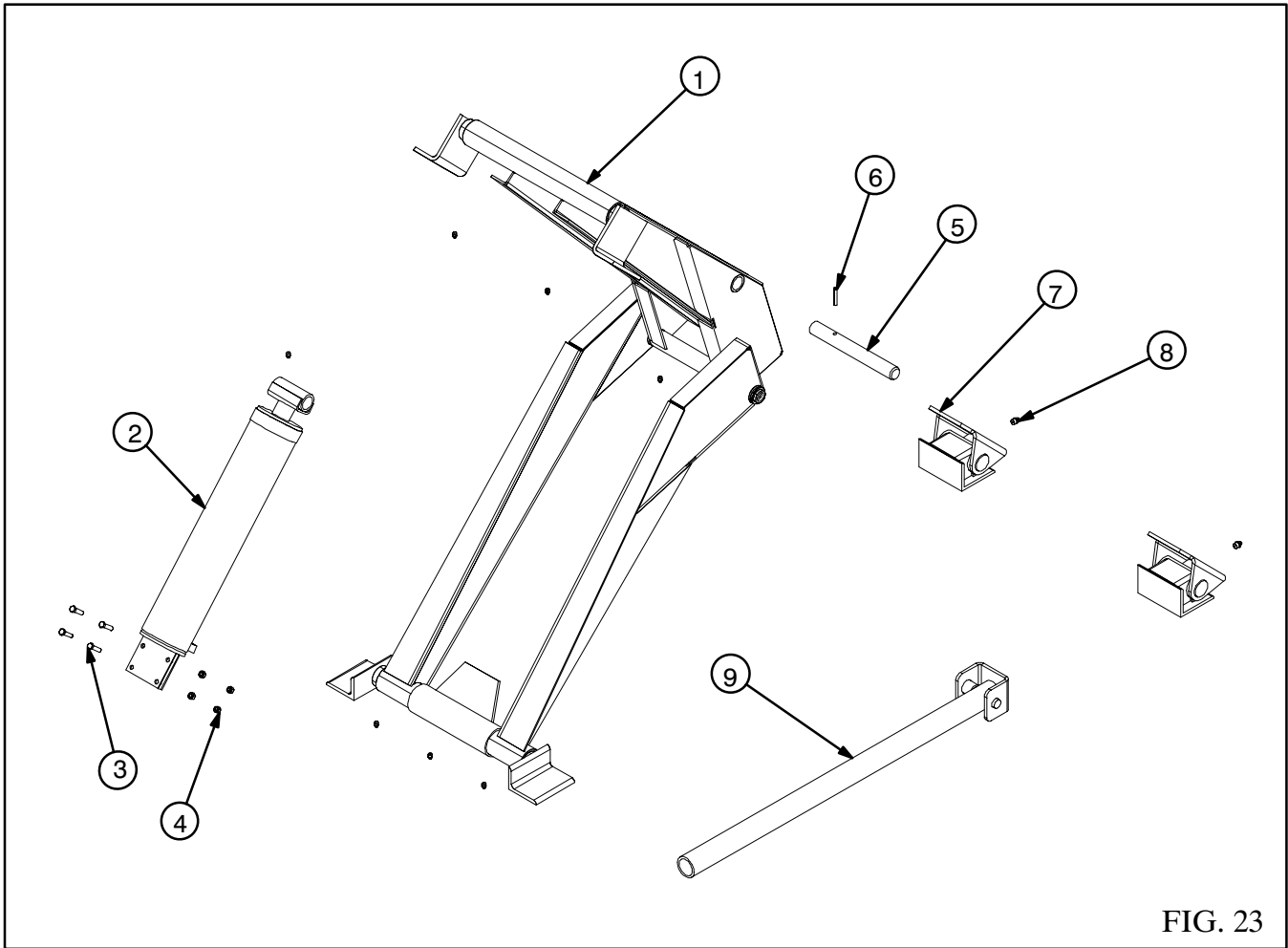

ITEM	DESCRIPTION	MODEL	PART NO.	QTY.
1.	Assy Frame – TR18	TR18	151707	1
2.	Assy Cylinder	TR10	104235	1
3.	Cap Screw 1/2–13 x 2 Gr 8	TR18	400105	4
4.	Hex Lock Nut 1/2–13	TR18	401316	4
5.	Crosshead Shaft	TR18	201173	1
6.	Spirol Pin 7/16 x 2 1/2	TR18	400208	1
7.	Assy Rear Hinge Pad – Med	TR18	146157	2
8.	Grease Zerk 1/8 NPT	TR18	400103	9
9.	Assy Body Prop	TR18	151451	1

TR3, TR5 & TR8 CYLINDER PARTS

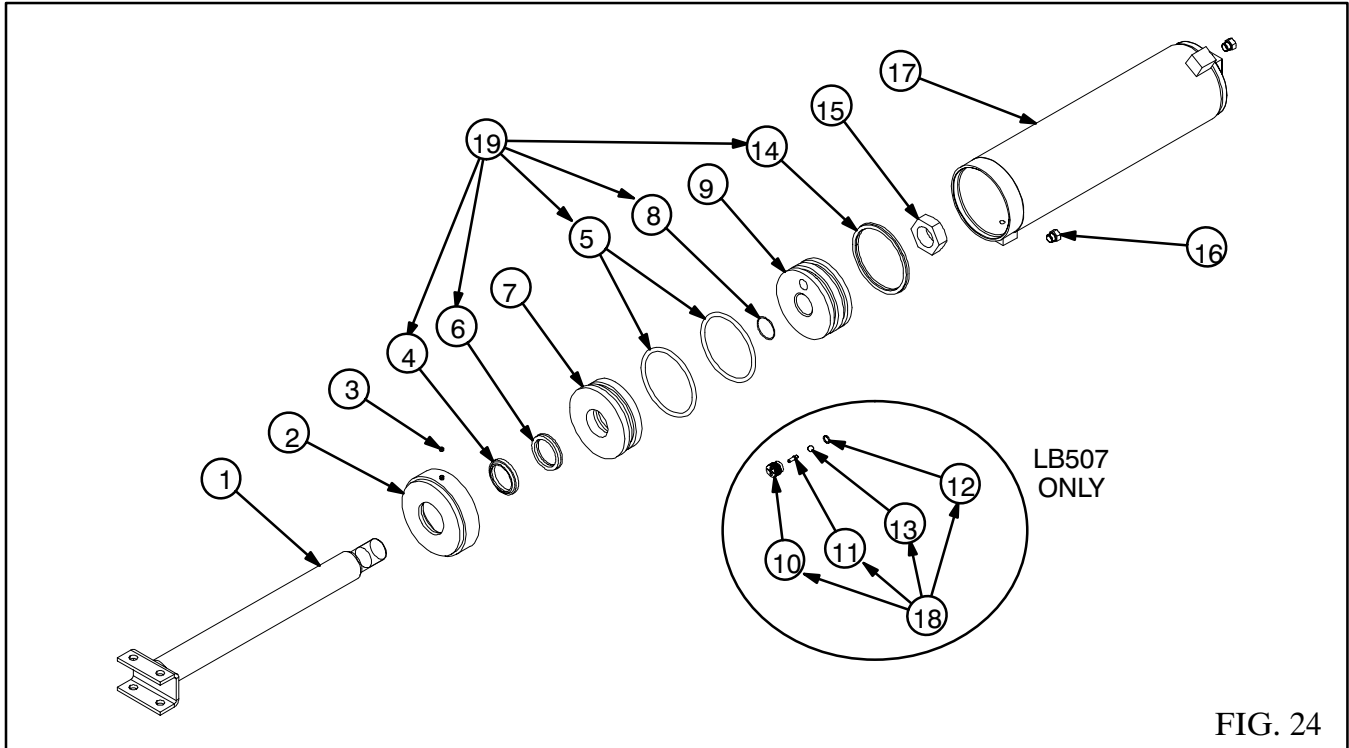

ITEM	DESCRIPTION	TR3 PART NO	TR5 PART NO	TR8 PART NO.	QTY.
1.	Shaft Assy	150984	105540	110306	1
2.	Cylinder Cap Assy		105541	104293	1
3.	Set Screw 1/4 x 3/16 Nylon Tip		400149	400149	1
4.	Wiper	401617	401133	400913	1
5.	O-Ring	406041	400263	400254	2
6.	Poly Seal	401132	401132	400253	1
7.	Cylinder Head	276970	406279	402469	1
8.	O-Ring	401131	401131	400255	1
9.	Cylinder Piston	215364	206755	202461	1
10.	Bypass Valve Body			400978	1
11.	Bypass Valve Pin			400979	1
12.	O-Ring 7/16			401017	1
13.	Steel Ball 3/8 Dia			400013	1
14.	Poly Seal	401645	400262	400252	1
15.	Hex Jam Nut			401370	1
16.	Plug 9/16-18 ORB	400404	400404	400404	2
17.	Cylinder Tube Assy	150983	105539	110305	1
18.	Bypass Valve Kit			105185	1
19.	Seal Kit		107958	107960	1

TR10, TR15 & TR18 CYLINDER PARTS

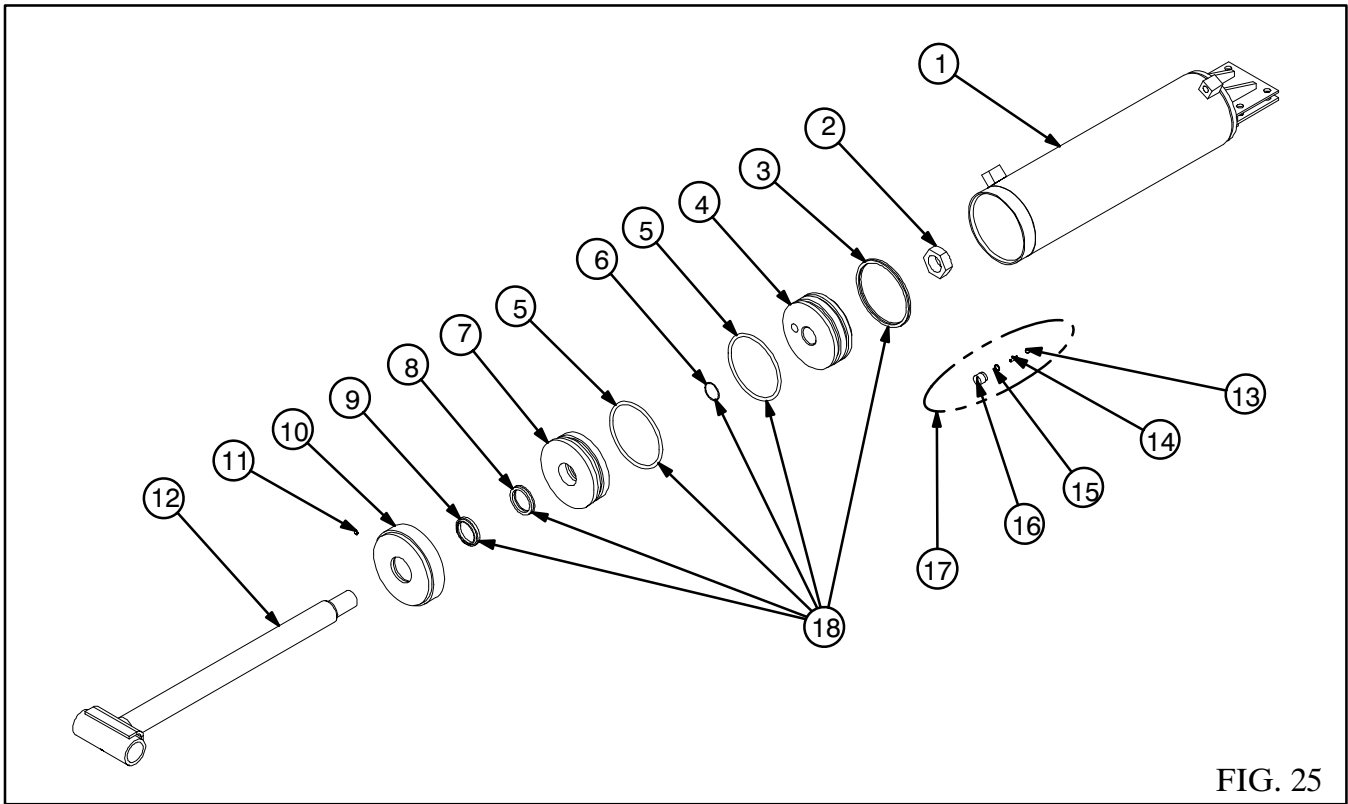

FIG. 25

ITEM	DESCRIPTION	MODEL	PART NO.	QTY.
1.	Assy Cylinder Tube	TR10	104303	1
	Assy Cylinder Tube	TR15	104306	1
	Assy Cylinder Tube	TR18	104272	1
2.	Hex Jam Nut 1 1/2-12	TR10, TR15 & TR18	401370	1
3.	Poly Seal 5" OD x 1/4 C.S.	TR10	400252	1
	Poly Seal 6" OD x 1/4 C.S.	TR15 & TR18	400257	1
4.	Piston 5"	TR10	202461	1
	Piston 6"	TR15 & TR18	202472	1
5.	O-Ring 4 1/2 ID x .275 C.S.	TR10	400254	2
	O-Ring 5 1/2 ID x .275 C.S.	TR15 & TR18	400258	2
6.	O-Ring 1 1/2 ID x .070 C.S.	TR10, TR15 & TR18	400255	1
7.	Head 5"	TR10	205128	1
	Head 6"	TR15	205130	1
	Head 6"	TR18	205104	1
8.	Poly Seal 2" ID x 1/4 C.S.	TR10 & TR15	400253	1
	Poly Seal 2 3/8" ID x 1/4 C.S.	TR8	400908	1
9.	Wiper 2" ID	TR10 & TR15	400913	1
	Wiper 2 3/8" ID	TR18	400915	1
10.	Assy Cylinder Cap 5" x 2"	TR10	104293	1
	Assy Cylinder Cap 6" x 2"	TR15	104298	1

	Assy Cylinder Cap 6" x 2 3/8"	TR18	104275	1
11.	Set Screw 1/4-20 Nylon Tip	TR10 & TR15	400149	1
12.	Assy Cylinder Shaft	TR10 & TR15	104305	1
	Assy Cylinder Shaft	TR18	104274	1
13.	Steel Ball 3/8 Dia	TR10, TR15 & TR18	400013	1
14.	Bypass Valve Pin	TR10, TR15 & TR18	400979	1
15.	O-Ring 7/16 ID x .070 C.S.	TR10, TR15 & TR18	401017	1
16.	Bypass Valve Body	TR10, TR15 & TR18	400978	1
17.	Kit Bypass Valve	TR10, TR15 & TR18	105185	1
18.	Kit Seal 5" Universal	TR10	107960	1
	Kit Seal 6" Universal	TR15 & TR18	107962	1

HYDRAULIC PARTS

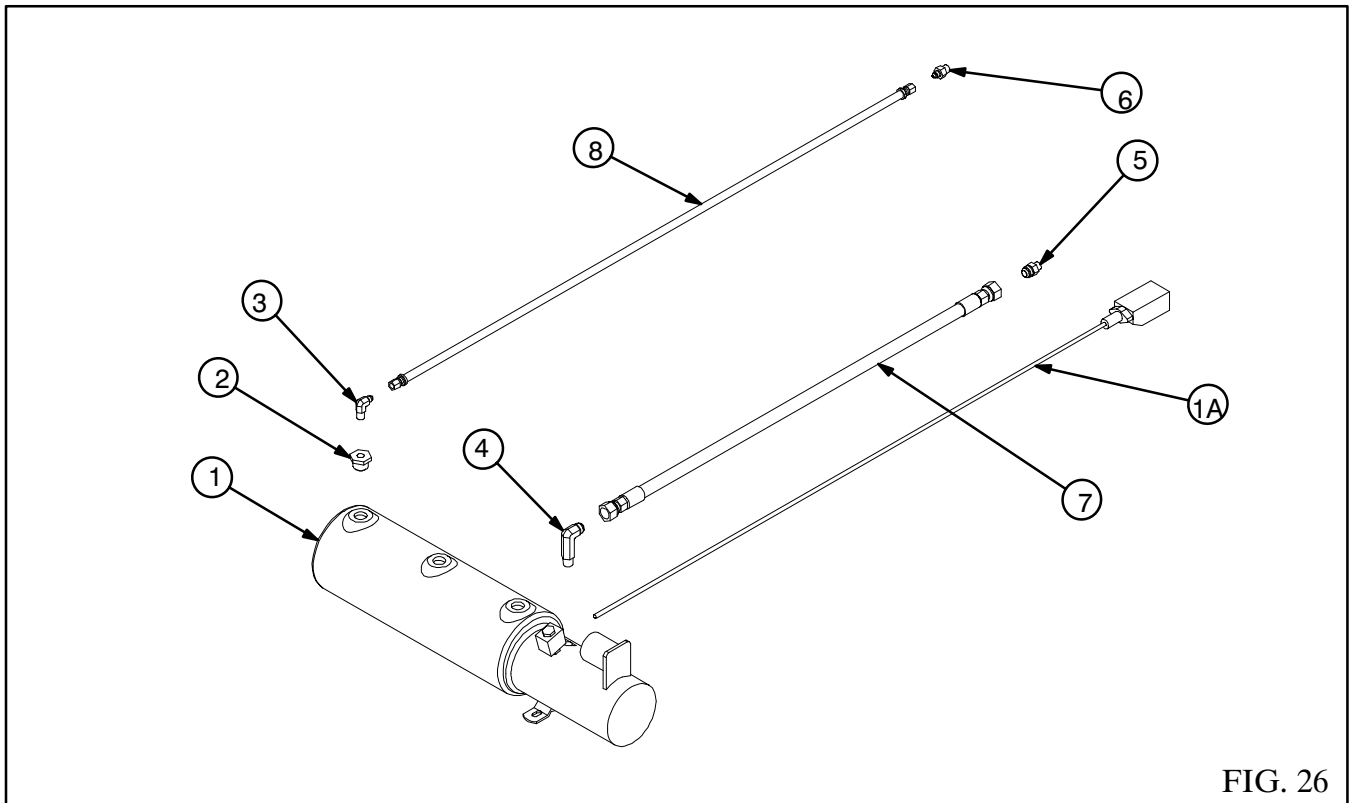

FIG. 26

ITEM	DESCRIPTION	MODEL	PART NO.	QTY.
1.	Electric Power Unit SA - 7 Qt	TR6DP, TR3, TR5. TR8 & TR10	406090	1
	Electric Power Unit SA - 20 Qt	TR15 & TR18	406119	1
1A.	Push-Button Control - 10' Cord	ALL	406157	1
2.	Bushing Hex 3/4 x 1/4	ALL	405501	1
3.	Adapter 7/16 JICM x 1/4 NPTM 90°	ALL	406151	1
4.	Adapter 3/4 JICM x 9/16 ORBM 90°	ALL	406116	1
5.	Adapter 3/4 JICM x 9/16 ORBM	TR6DP, TR3, TR5 & TR8	402516	1

	Adapter 3/4 JICM x 3/8 NPTM	TR10, TR15 & TR18	402789	1
6.	Adapter 7/16 JICM x 9/16 ORBM	TR6DP, TR3, TR5 & TR8	406152	1
	Adapter 7/16 JICM x 3/8 NPTM	TR10, TR15 & TR18	406153	1
7.	Hose 3/4 JIC x 36 SF/SF 4000	ALL	404898	1
	Hose 3/4 JIC x 42 SF/SF 4000	ALL	402489	1
	Hose 3/4 JIC x 48 SF/SF 4000	ALL	402490	1
	Hose 3/4 JIC x 54 SF/SF 4000	ALL	406120	1
	Hose 3/4 JIC x 60 SF/SF 4000	ALL	402517	1
	Hose 3/4 JIC x 66 SF/SF 4000	ALL	403311	1
	Hose 3/4 JIC x 72 SF/SF 4000	ALL	404906	1
	Hose 3/4 JIC x 78 SF/SF 4000	ALL	406121	1
	Hose 3/4 JIC x 84 SF/SF 4000	ALL	406122	1
	Hose 3/4 JIC x 90 SF/SF 4000	ALL	406128	1
	Hose 3/4 JIC x 96 SF/SF 4000	ALL	406129	1
8.	Hose 7/16 JIC x 48 SF/SF 250	ALL	406130	1
	Hose 7/16 JIC x 54 SF/SF 250	ALL	406139	1
	Hose 7/16 JIC x 60 SF/SF 250	ALL	406140	1
	Hose 7/16 JIC x 66 SF/SF 250	ALL	406141	1
	Hose 7/16 JIC x 72 SF/SF 250	ALL	406142	1
	Hose 7/16 JIC x 78 SF/SF 250	ALL	406143	1
	Hose 7/16 JIC x 84 SF/SF 250	ALL	406144	1
	Hose 7/16 JIC x 90 SF/SF 250	ALL	406145	1
	Hose 7/16 JIC x 96 SF/SF 250	ALL	406146	1

SPECIFICATIONS

Hoist Model	Cylinder Bore	Cylinder Stroke	Cylinder Shaft	Operating Pressure
TR3	3 1/4"	11"	1 1/2"	3250 PSI
TR5	4"	15 1/4"	1 1/2"	3250 PSI
TR8	5"	15 1/4"	1 1/2"	3250 PSI
TR10	5"	19 3/8"	2"	3250 PSI
TR15	6"	19 3/8"	2"	3250 PSI
TR18	6"	27 1/2"	2 3/8"	3250 PSI

CAPACITY FORMULA

The capacity of the Colt trailer hoists can be calculated using the following steps.

1. Measure the distance, in inches, from the center of the rear hinge to the center of the body. Call this "A".
2. Measure the distance, in inches from the center of the rear hinge to the forward crosstube on the hoist. Call this "D". (See Figures 2, 3 & 4 for "D" dimensions for the various models.)
3. For Model TR3, multiply "D" by 2.76.
For Model TR5, multiply "D" by 3.78.
For Model TR8, multiply "D" by 5.91.
For Model TR10, multiply "D" by 6.51.
For Model TR15, multiply "D" by 8.83.
For Model TR18, multiply "D" by 9.00.
4. Divide the result of Step 3 by "A". This is the capacity in tons for an evenly distributed load (over the whole length of the body) and includes the weight of the body.

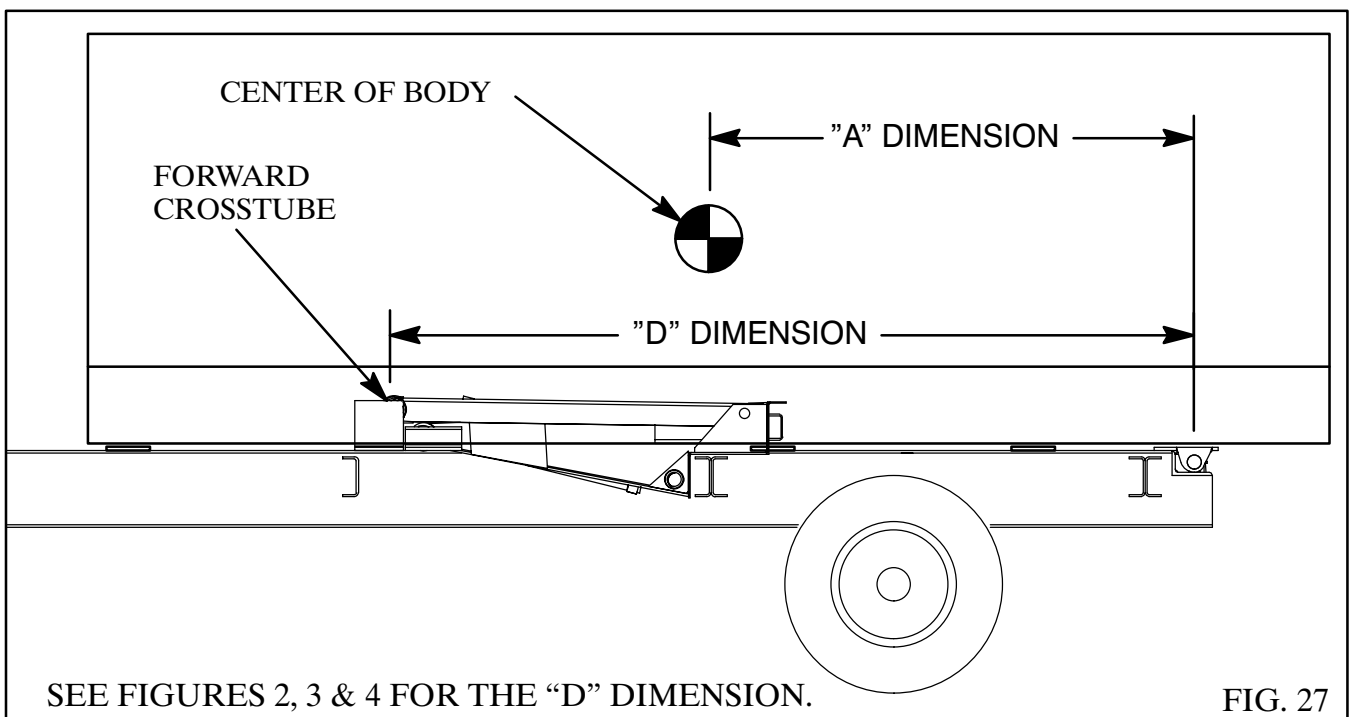

NOTES

SPECIALLY DESIGNED – WITH QUALITY IN MIND

WARRANTY

- Crysteel Manufacturing, Inc. warrants its products for a period of one year from date of purchase.
- The warranty provides that our products must perform satisfactorily or we will repair, replace or refund the purchase price at the option of the purchaser. Hydraulic pumps, valves, hoses and other purchased parts are covered by the warranties of their respective manufacturers.
- Any parts returned to Crysteel Manufacturing, Inc. shall be shipped prepaid, and will be returned F.O.B. Lake Crystal, Minnesota.
- We will not assume responsibility for shipping, labor, travel, loss of use or downtime expenses.
- The warranty is void if the product has been obviously abused, or subjected to other than normal usage.
- We reserve the right to make improvements without notice or obligation regarding models previously sold.



CRYSTEEL MANUFACTURING, INC.

P.O. Box 178 52182 Ember Road
Lake Crystal, MN 56055

1902 Route 57 South
Fulton, NY 13069

(507) 726-2728 (800) 533-0494