

# CRYSTEEL'S

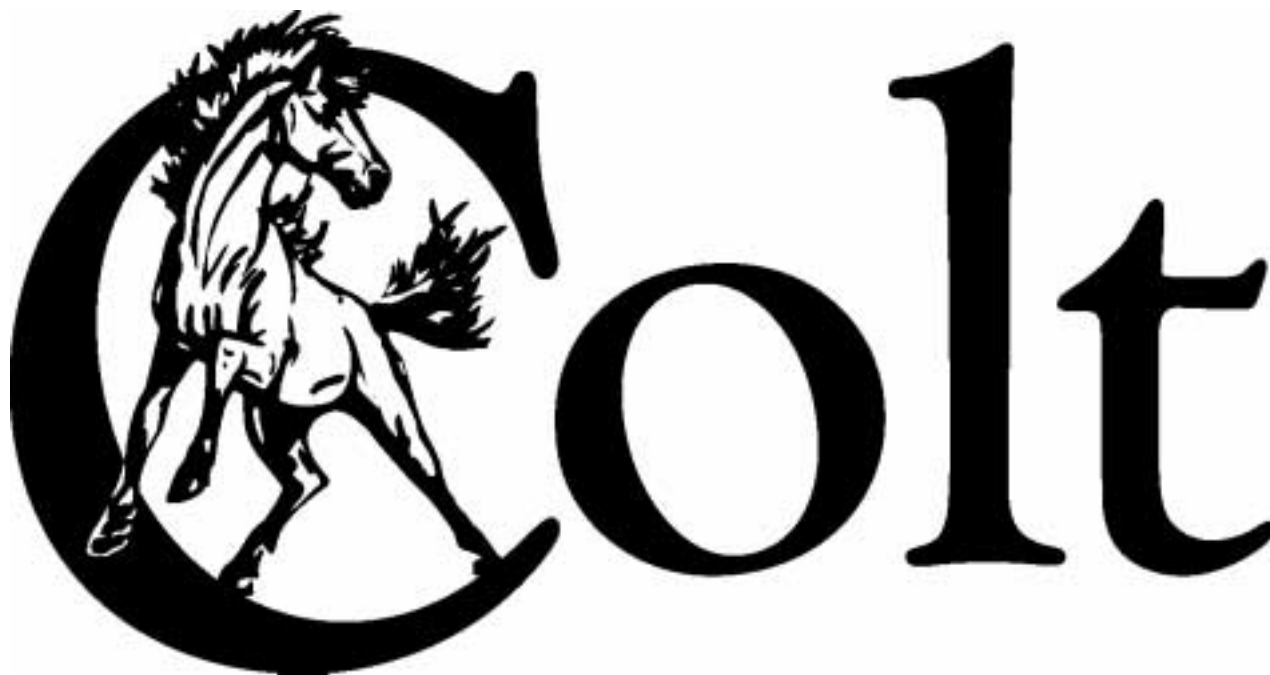

## SCISSOR TRAILER HOIST



USE WITH  
HOISTS WITH  
THIS LABEL

### NOTICE

THIS IS A NEW COLT MODEL!  
THE MOUNTING DISTANCES HAVE  
CHANGED.

PLEASE REFER TO THE NEW  
INSTALLATION MANUAL,  
P/N 406596, DATED 4/16/2004.

THIS NEW MANUAL IS FOUND IN  
CARTONS WITH A SIMILAR DECAL.

REMOVE THIS DECAL DURING INSTALLATION. P/N 80658

P.O. Box 178  
52182 Ember Road  
Lake Crystal, MN 56055

[www.colthoists.com](http://www.colthoists.com)  
[colthoist@crysteel.com](mailto:colthoist@crysteel.com)  
(507) 726-2728 (800) 533-0494

1902 Route 57 South  
Fulton, NY 13069

**DATE PURCHASED** \_\_\_\_\_  
**HOIST SERIAL NUMBER** \_\_\_\_\_  
**CYLINDER SERIAL NUMBER** \_\_\_\_\_  
**DEALER** \_\_\_\_\_  
**ADDRESS** \_\_\_\_\_  
**PHONE** \_\_\_\_\_

### FOREWORD

This manual contains the information needed for the proper installation and operation of these hoists.

These instructions are for installing and maintaining all Colt trailer scissor hoists. With proper installation, use, and regular maintenance, Crysteel's Colt trailer hoists will give many years of trouble free service.

When ordering parts, be sure to give serial number of hoist and cylinder. The serial number of the hoist is stamped into the hoist frame near the base end of the cylinder. The serial number of the cylinder is stamped on the barrel of the cylinder near the base. For future reference, copy these numbers NOW in the space provided above. Order parts by number and description as given in the parts listing in this manual.

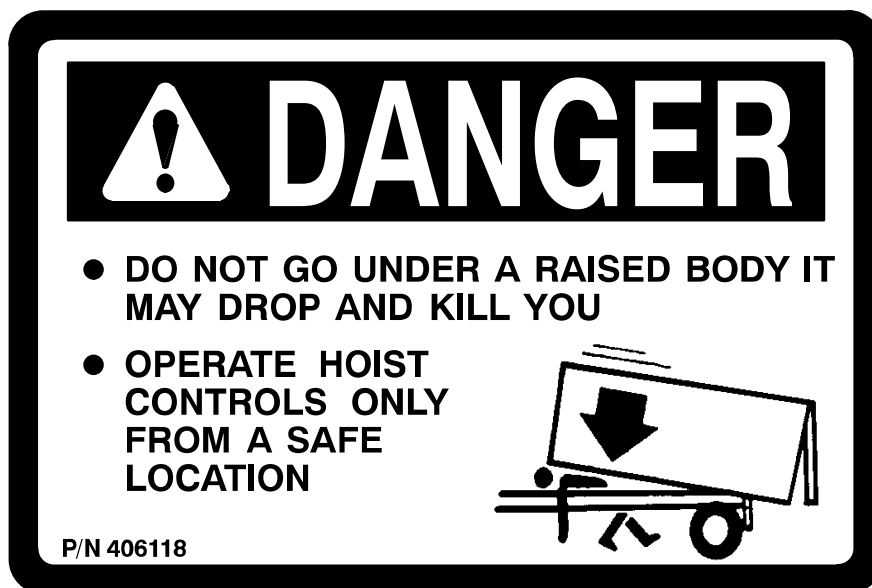

## **OPERATION AND USE**

1. Operate hoist controls only from a safe location.
2. To raise the hoist, press and hold the 'UP' button. To hold the body in a raised position, release the 'UP' button. To lower the hoist, press and hold the 'DOWN' button.
3. Grease the hoist every 100 cycles or every two months
4. To use the body prop, raise the body, raise the body prop arm to its upright position and lower the body onto the body prop arm.
5. To lower the body prop, raise the body, lower the body prop arm to its storage position and lower the body.
6. The fluid in the electric power unit should be changed annually. Use automatic transmission fluid (Dexron II or equivalent) Clean the breather cap each time the fluid is changed.

## **SOME DO'S AND DON'TS FOR SAFE AND LONG SERVICE**

1. Use the proper hydraulic fluid. **KEEP IT CLEAN.** Remember to change it regularly.
2. Lubricate all grease fittings at regular intervals.
3. **ALWAYS** carefully block up the body, using the body prop, before working under it.
4. Do not load the hoist beyond its capacity.
5. **DO NOT** tamper with the hydraulic relief valve. This will void the warranty. It can cause severe damage to the hoist and cylinder.
6. Check all bolts and fittings regularly. **Keep them tight.**

## TABLE OF CONTENTS

Purchase Record	1
Foreword	1
Operation and Use	2
Some Do's and Don't's	2
Table of Contents	3
Hoist Mounting Methods	4
Locate and Mount Hoist	5
Two–Crossmember Mounting	6
Install Rear Hinge	6–7
Mount Electric Power Unit	7
Connect Hoses – Single–Acting	8
Connect Hoses – Double–Acting	9
Add Automatic Transmission Fluid	13
Install Body	11
Down Speed	11
Install Body Guides	11
Install Body Prop	12
Install Grease Zerks and Lubricate	13
Install Decals	14
Parts Lists and Diagrams	15–20
Specifications	21
Capacity Formula	21

# INSTALLATION INSTRUCTIONS

## HOIST MOUNTING METHODS

The following illustrations show three methods of trailer frame construction for mounting the hoist frame and cylinder.

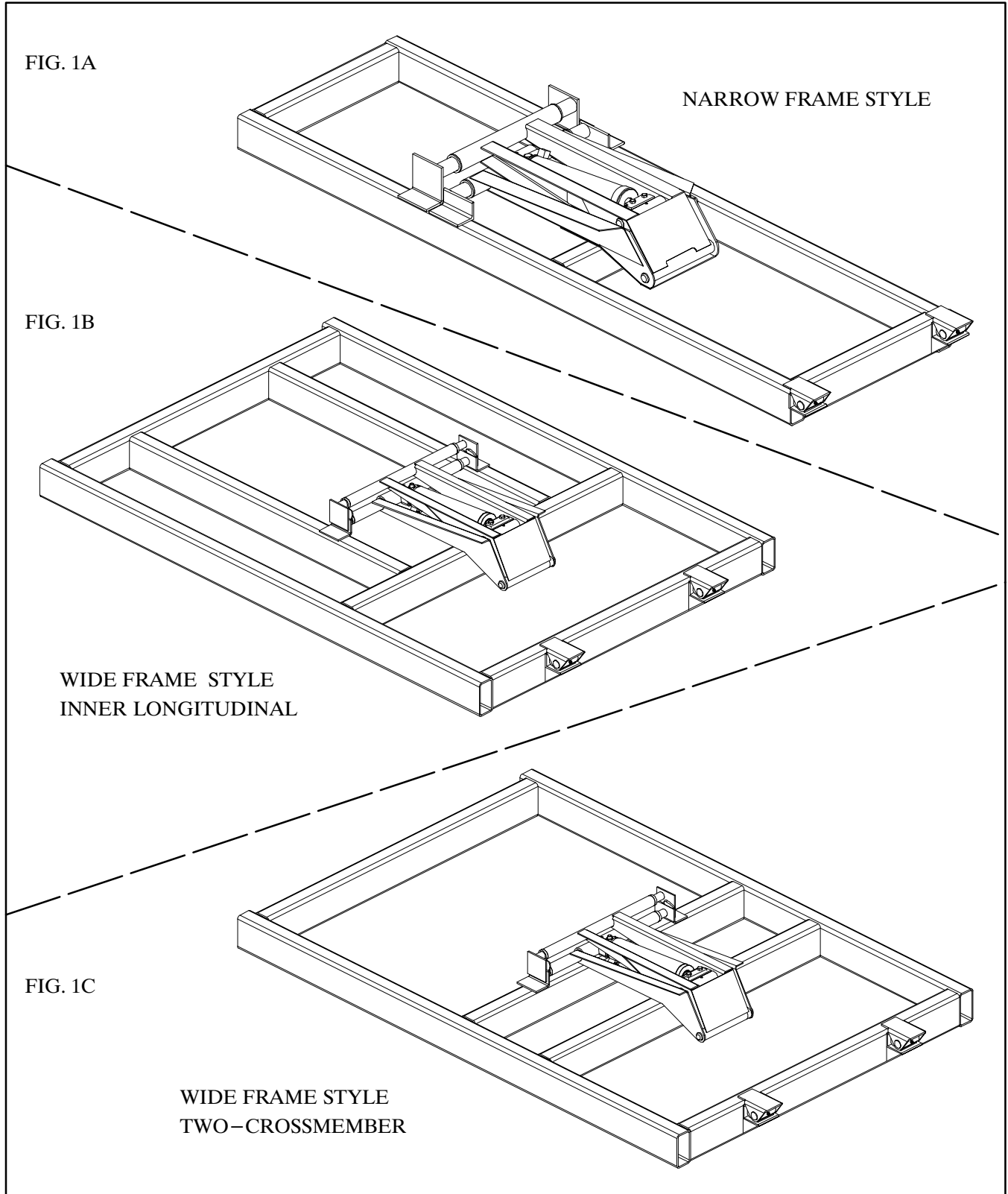

## LOCATE AND MOUNT HOIST

Determine where to mount the hoist on the trailer. Please refer to the chart in Fig. 2 for the relationship between dump angle and “D” dimension. Measure forward from the center of the rear hinge pin and mark, on the trailer frame, the location of the front crosstube of the hoist frame. Place the hoist on the trailer frame and clamp the hoist pivot pads to the trailer frame. The hoist should be level with the trailer frame. The back end of the hoist must be supported by a crossmember in the trailer frame. The “CM” dimension shows the location for this crossmember. Make sure the hoist frame is centered on and square with the trailer frame. Securely weld the lower hoist pivot pads to the trailer frame. Remove the clamps.

If desired, the hoist can be turned end for end for a 'Reverse' mount. This does not affect the lifting capacity.

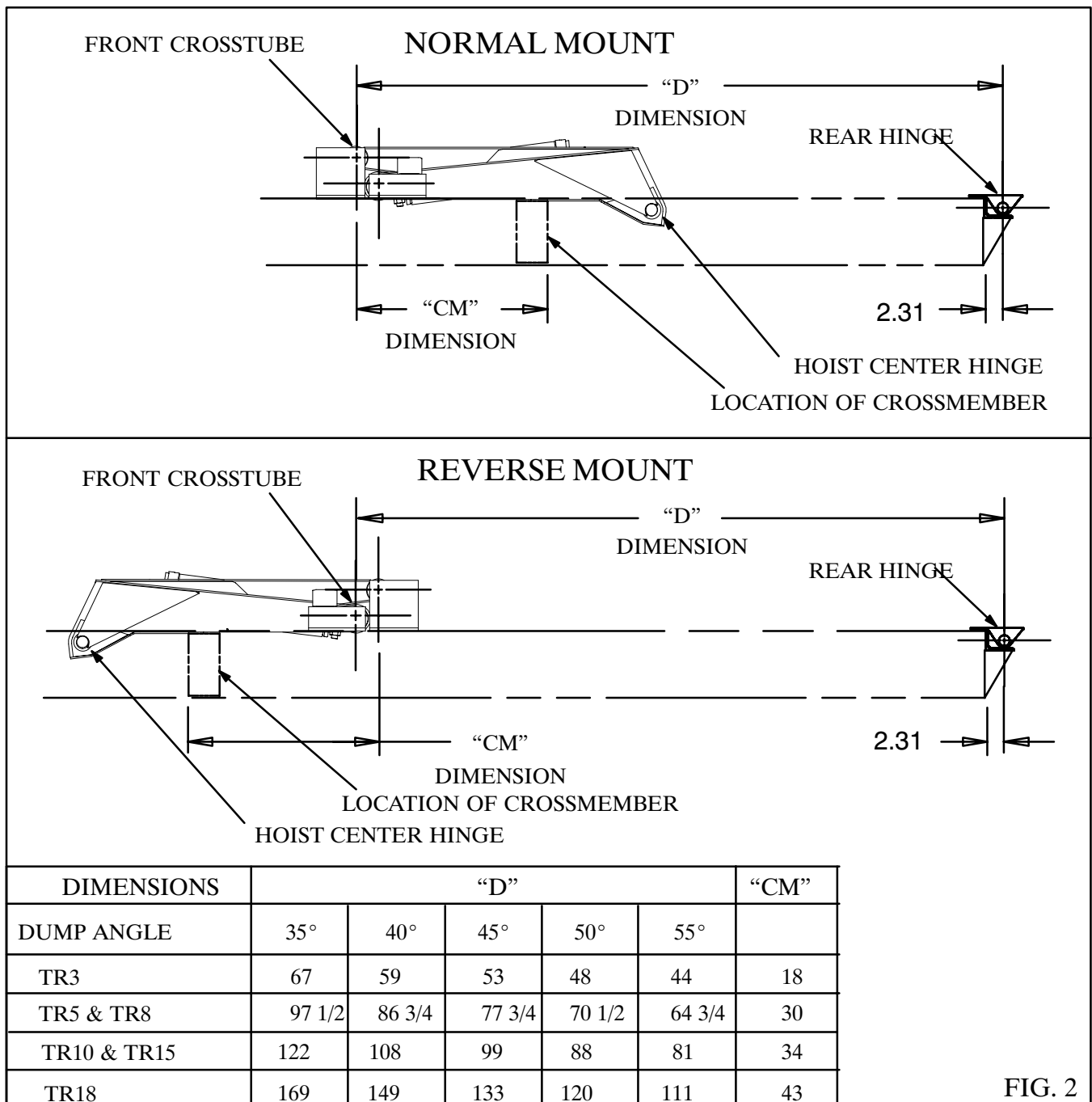
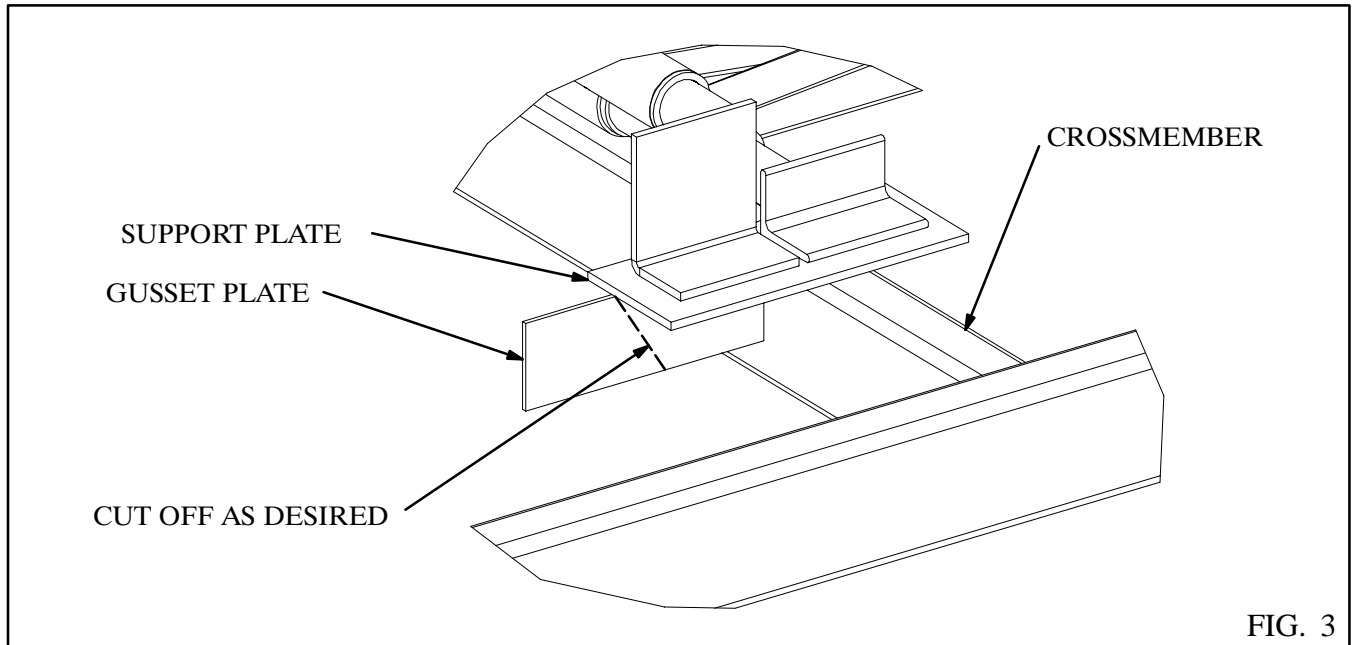

FIG. 2

## TWO – CROSSMEMBER MOUNTING

It is important that both upper and lower mounting angles on the hoist frame be supported. For the narrow and inner longitudinal frame versions (Figures 1A & 1B), both angles rest on the longitudinals. When mounting the Colt trailer hoist on a crossmember, as shown in Figure 1C, supporting plates must be used. Place the supporting plate on the crossmember and the gusset plate underneath it. Trim off the excess material of the gusset plate. See Figure 3.



## INSTALL REAR HINGE

Crysteel's rear hinge pads are designed to be welded to the rear crossmember of the trailer frame as shown in Figures 4 and 5. The Colt trailer hoists and rear hinge are designed so the longbeams of the platform sit on the mounting angles of the hoist frame and on top of the rear hinge pad. When locating the rear hinge pads, be sure the top of the hinge pad is even with the top of the hoist mounting angles and that they are aligned with each other. Fully weld the rear hinge angles to the trailer frame as shown in Figures 4 & 5. Trim braces under the rear hinge angle if needed. See Figure 4.

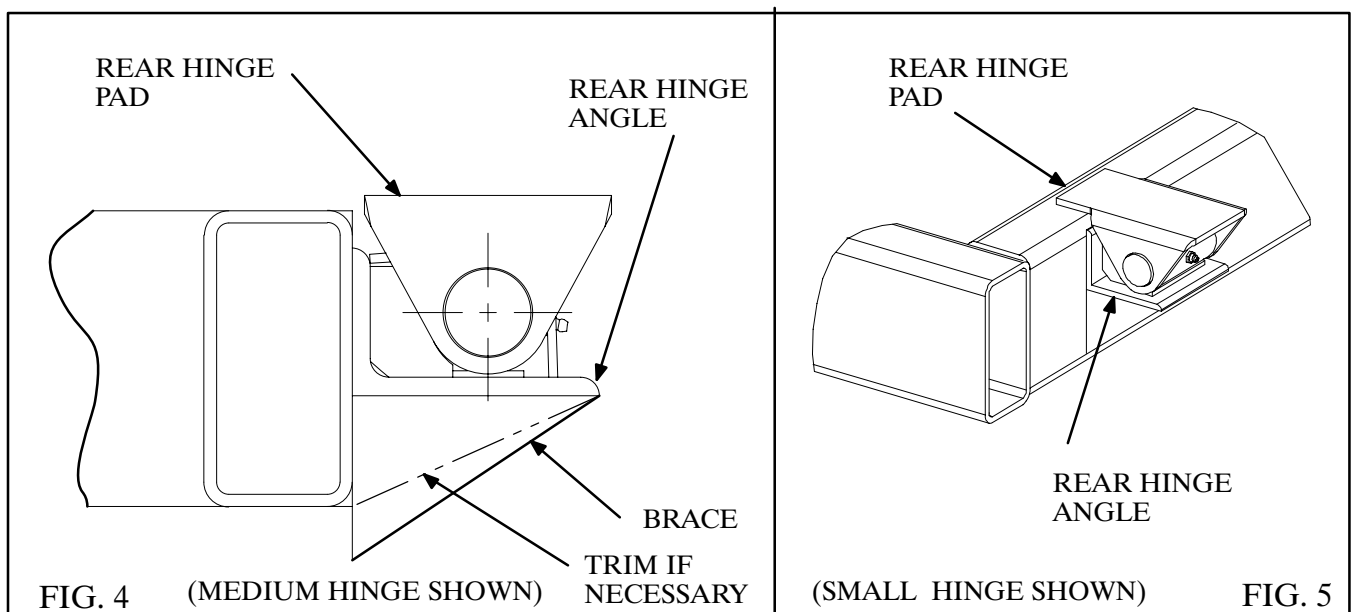

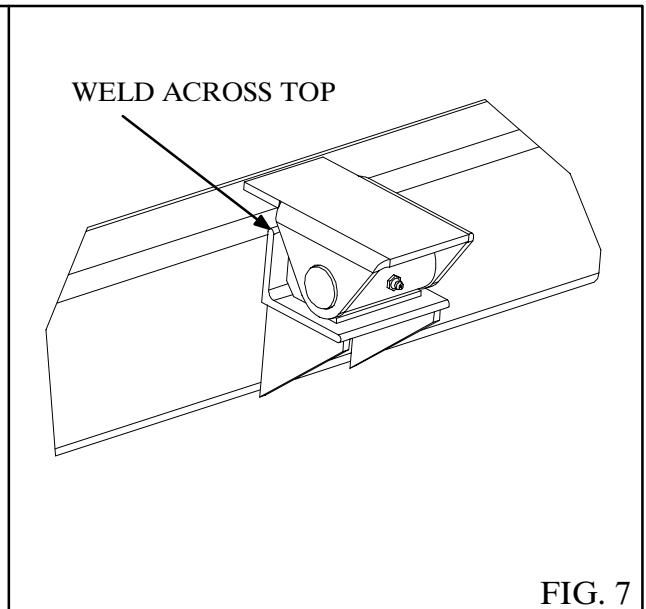
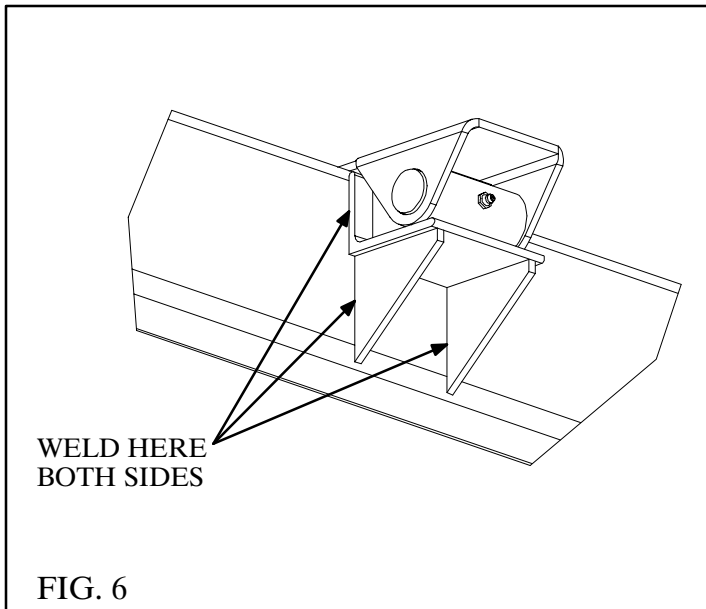

## MOUNT ELECTRIC POWER UNIT

The electric power unit and the battery should be mounted in a protected area. Bolt the power unit in place using the 3/8 x 1 hex head cap screws, tightening to 24 to 26 lb–ft.

Connect the large terminal on the motor start solenoid to the positive terminal on the battery with a #0 gauge battery cable. Connect the negative terminal on the battery to one of the mounting screws on the power unit using a #0 gauge battery cable, or equivalent size ground strap.

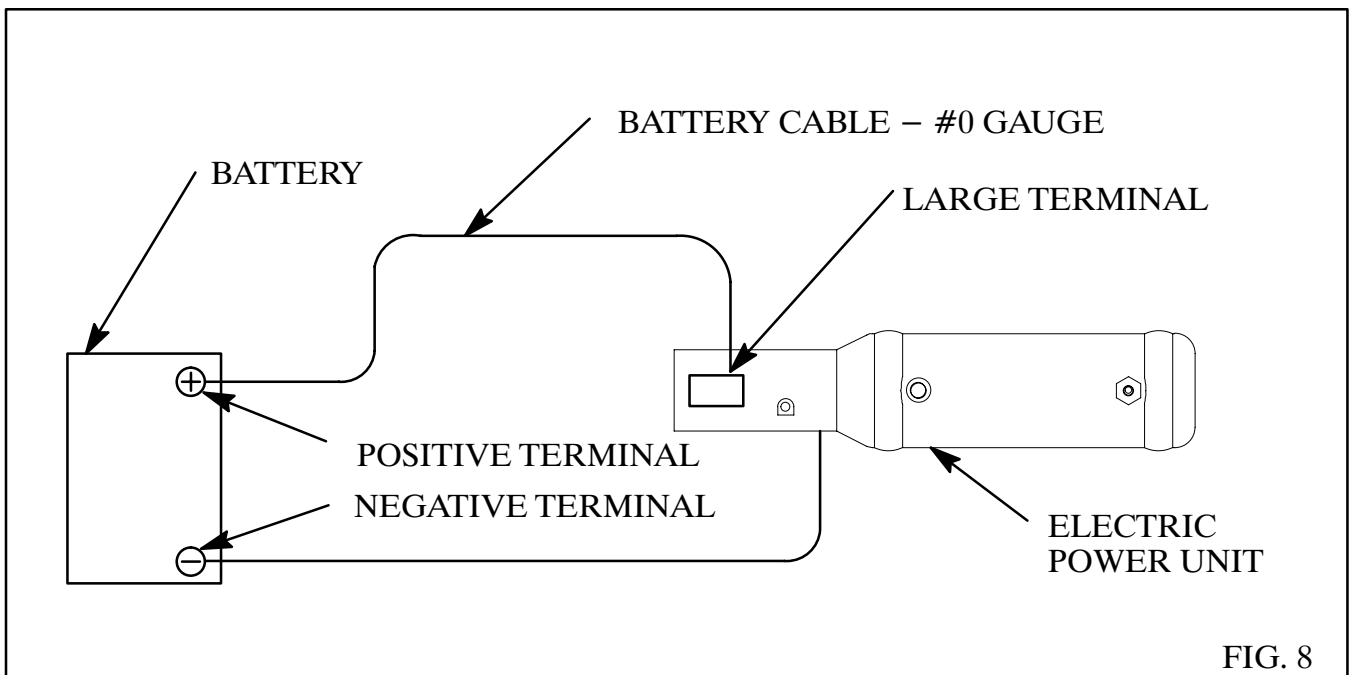

The hoist control should be operated only from a safe location. Mount the hoist control pendant in a safe location.



## CONNECT HOSES – SINGLE-ACTING

Install a 1/4 NPT x 7/16 JIC male elbow in a 3/4 x 1/4 hex bushing and install this in the port on the top of the reservoir.

For TR3, TR5 and TR8 hoist models, install a 9/16 ORB x 3/4–16 JIC male adapter in the base–end cylinder port; install a 9/16 ORB x 7/16–16 JIC male adapter in the rod–end cylinder port. Install a 9/16 ORB x 3/4–16 JIC male elbow in the power port on the electric power unit.

Connect a 3/8” hose (3500 psi minimum pressure rating) to the base end cylinder port on the hoist and to the power port on the electric power unit. Connect a 1/4” hose (250 psi minimum pressure rating) to the rod end cylinder port and to the reservoir on the electric power unit. See Figure 9.

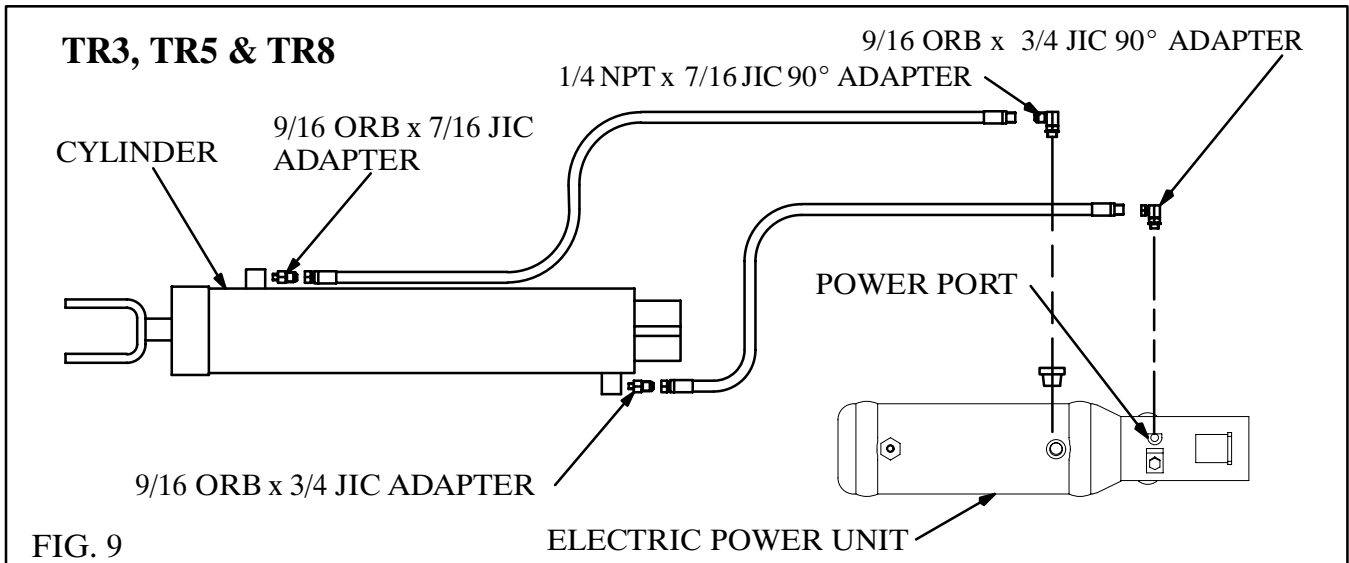

For TR10, TR15 and TR18 hoist models, install a 3/4 ORB x 3/4–16 JIC male adapter in the base–end cylinder port; install a 3/4 ORB x 7/16–16 JIC male adapter in the rod–end cylinder port. Install a 9/16 ORB x 3/4–16 JIC male elbow in the power port on the electric power unit.

Connect a 3/8” hose (3500 psi minimum pressure rating) to the base end cylinder port on the hoist and to the power port on the electric power unit. Connect a 1/4” hose (250 psi minimum pressure rating) to the rod end cylinder port and to the reservoir on the electric power unit. See Figure 10.

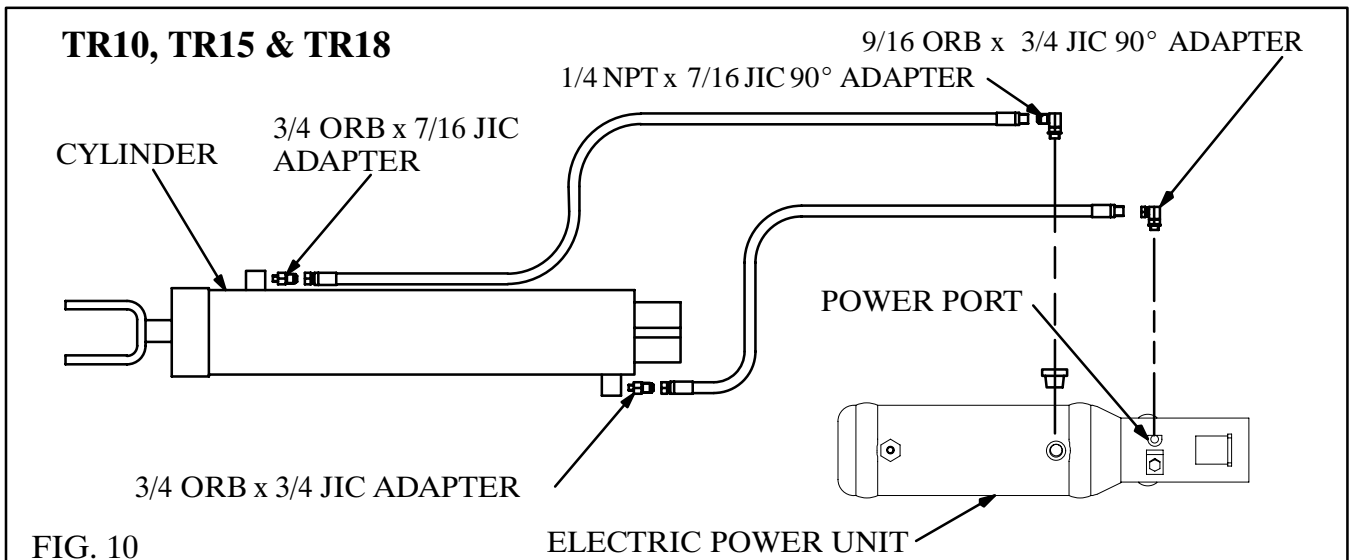

## CONNECT HOSES – DOUBLE–ACTING

*NOTE: When using a double–acting power unit, the rod end hose MUST be rated to 3500 psi.*

Install 9/16 ORB x 3/4 JIC 90° swivel adapters in both work ports on the electric power unit. If needed, for good hose routing, install 3/4 JIC x 3/4 JIC 90° swivel adapters to both of these adapters. (see Figures 14, 15 & 16.)

For TR3, TR5 and TR8 hoist models, install 9/16 ORB x 3/4–16 JIC straight adapters in both cylinder ports. Connect a 3/8” hose (3500 psi minimum pressure rating) from the ‘C1’ port on the pump to the base end port on the cylinder. Connect a second 3/8” ID hose (3500 psi minimum pressure rating) from the ‘C2’ port to the rod end port. (See Figure 11.)

*NOTE: The ‘C2’ port is the power down port and has only 500 PSI maximum pressure.*

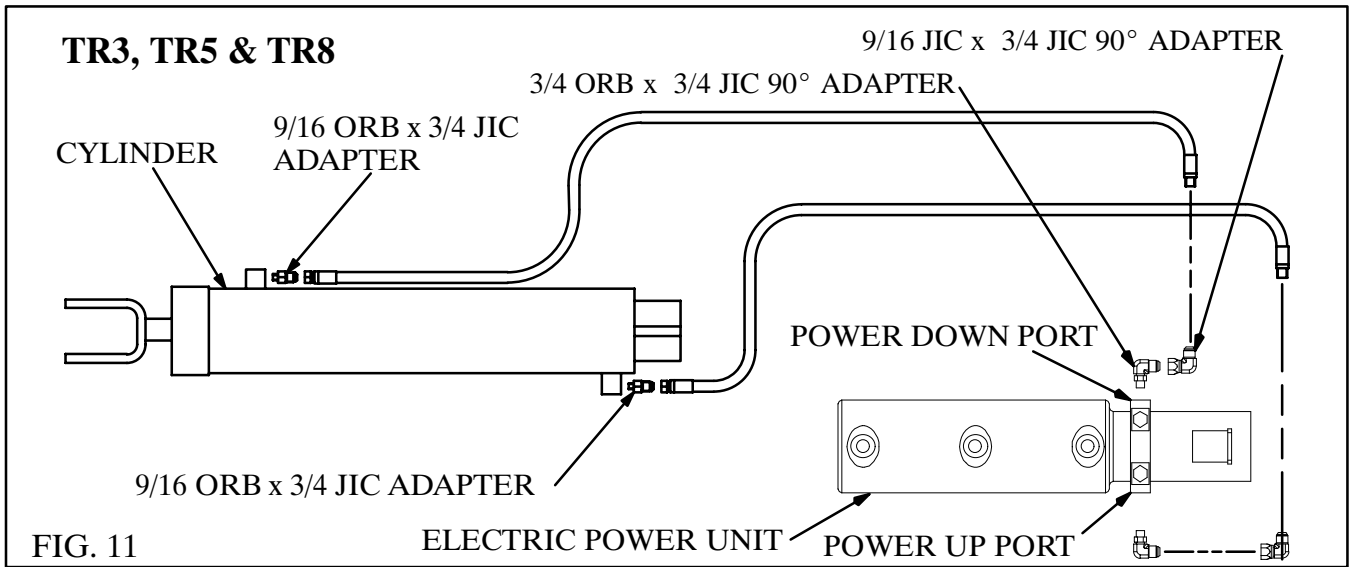

For TR10, TR15 and TR18 hoist models, install 3/4 ORB x 3/4–16 JIC straight adapters in both cylinder ports. Connect a 3/8” hose (3500 psi minimum pressure rating) from the ‘C1’ port on the pump to the base end port on the cylinder. Connect a second 3/8” ID hose (3500 psi minimum pressure rating) from the ‘C2’ port to the rod end port. (See Figure 12.)

*NOTE: The ‘C2’ port is the power down port and has only 500 PSI maximum pressure.*

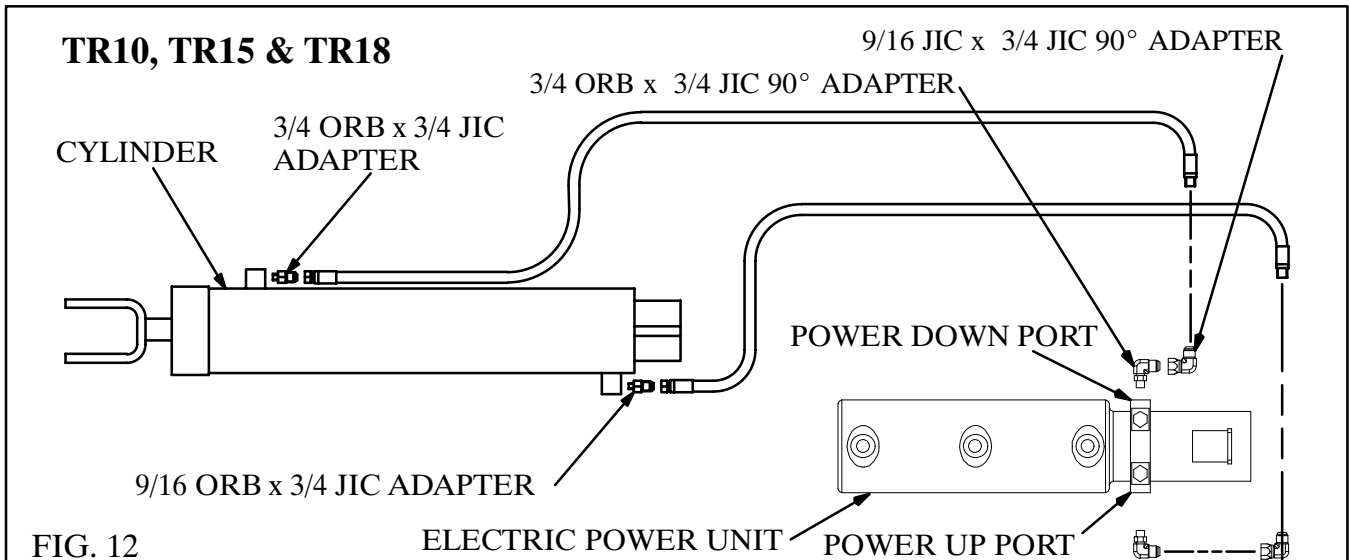

## **ADD AUTOMATIC TRANSMISSION FLUID**

For the TR3, TR5, TR8 and TR10, with single-acting electric power units, add 7 quarts of DEXRON II automatic transmission fluid to the reservoir. For the TR15 and TR18 with single-acting electric power units, add 20 quarts of DEXRON II automatic transmission fluid. **DO NOT OVERFILL THE RESERVOIR!** Fully raise the hoist and hold the 'UP' button for 15 seconds. This will remove the air that is inside the cylinder. Raise and lower the hoist several times and check the fluid level in the reservoir. Add fluid as needed.

For all models with double-acting electric power units, add 7 quarts of DEXRON II automatic transmission fluid. **DO NOT OVERFILL THE RESERVOIR.** For the TR15 and TR18, raise the hoist until there is 2" of ATF in the reservoir. Add 2 quarts and raise the hoist until there is 2" of ATF in the reservoir. Repeat this until the hoist can be fully raised. Fully raise the hoist and hold the 'UP' button for 15 seconds. This will remove the air that is inside the cylinder. Raise and lower the hoist several times and check the fluid level in the reservoir. Add fluid as needed.

***KEEP THE ATF CLEAN! USE CLEAN CONTAINERS, FUNNELS AND OTHER EQUIPMENT!***

With normal use and working conditions the automatic transmission fluid should be changed annually. The breather cap should be cleaned every time the automatic transmission fluid is changed. With heavy use or very dusty working conditions the automatic transmission fluid should be changed more often.

***NOTE: If a single-acting power unit is being replaced by a double-acting power unit, the 250 psi rated rod end hose must be replaced with a 3500 psi rated hose.***

## INSTALL BODY

Place the body in position on the trailer frame. Align the body longbeams carefully with the trailer frame. Securely weld the longbeams to the rear hinge pads and to the upper hoist pivot pads.

If the body has channel longbeams, weld a spacer (not supplied) to the top of the upper hoist pivot pads and to the top flange of the longbeam channels as shown in Figure 13. If the body has tubular longbeams or channel longbeams with the legs out, weld the hoist pivot pads to the inside of the inside of the longbeam as shown in Figure 14. Be sure to do this on both sides.

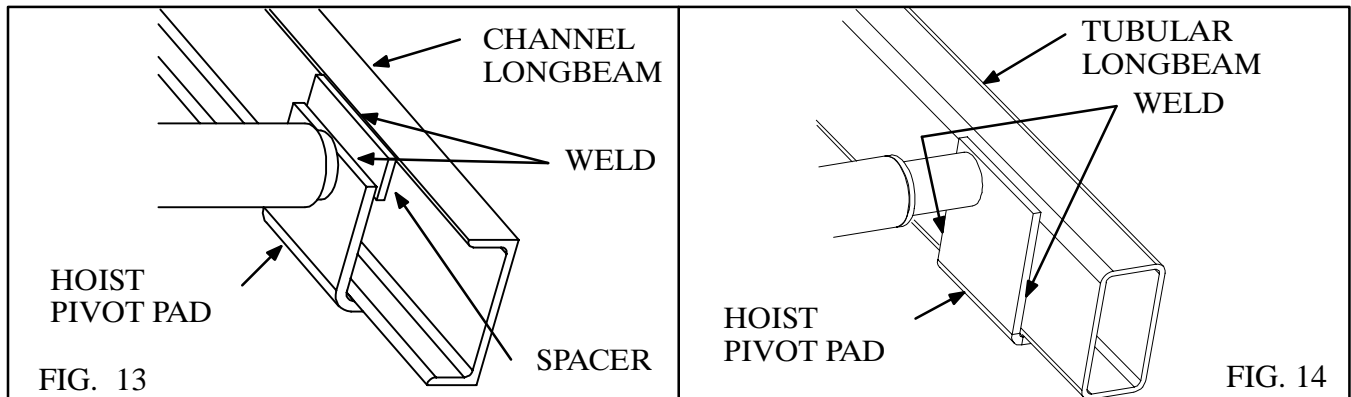

***DO NOT WORK UNDER A RAISED BODY UNLESS THE BODY IS SECURELY BLOCKED OR PROPPED IN THE RAISED POSITION.***

## DOWN SPEED

Once the hoist is installed raise the hoist to its full stroke and time the down cycle. Crysteel Mfg. recommends a lowering time of 15 seconds or longer for an empty body (the time will vary depending on body weight and ambient temperature). If the down cycle time is less than 15 seconds, contact Crysteel to purchase an optional flow control kit. Flow control kits are available from Crysteel in different flow rates to control the down speed.

## INSTALL BODY GUIDES

Crysteel Mfg. recommends that guides be used to keep the body and trailer frame aligned when the body is down. The Colt hoist frames have body guides built into the lower mounting angles. Space body longbeams, or add filler plates, to get 1/8" gap between inside of longbeams and body guides.

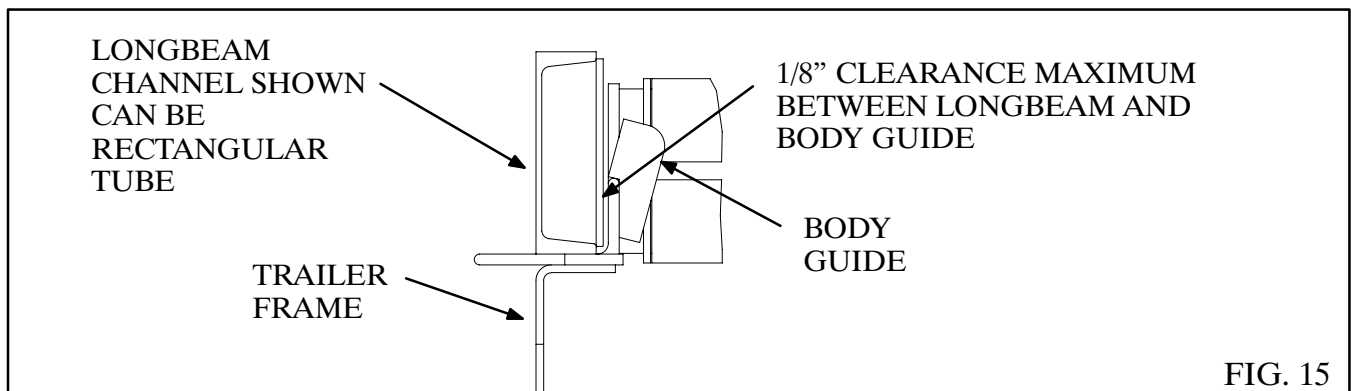

## INSTALL BODY PROP

The body prop is designed and intended to support an EMPTY trailer body in the raised position. Use of the body prop permits service to be performed safely beneath a raised body. Install the prop on the trailer as explained below and shown in Fig. 16.

1. Raise the body to a 20° to 30° angle and brace it securely before beginning installation.
2. Clamp the prop pivot against the outside of the trailer frame. Raise the body prop arm to a free standing position. Reposition the prop if needed to locate the prop bracket on the longbeam. It may be necessary to raise or lower the body to get the best location for the prop pivot mount. Securely weld the prop pivot to the trailer frame.
3. A pocket needs to be constructed on the body to prevent the top end of the prop tube from sliding forward or back or from side-to-side.
4. To operate the body prop, raise the body to the desired height, raise the prop arm to a free standing position. Lower the body slowly until the body contacts the prop arm.
5. To place the body prop in the storage position, raise the body to clear the body prop, lower the body prop to the storage position and lower the body.

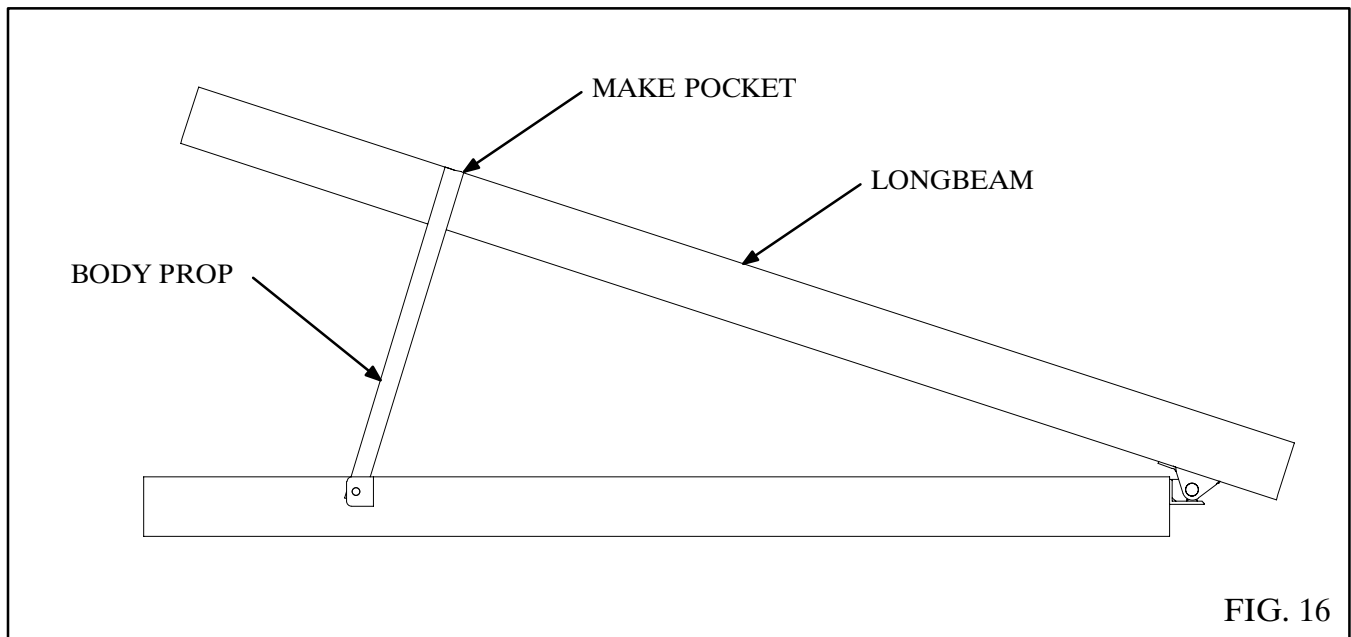

# INSTALL GREASE ZERKS AND LUBRICATE

Install grease zerks in the hoist frame. Lubricate all fittings at regular intervals, at least every 100 cycles or every two months. The grease fittings are located (See Fig. 17.) as follows:

- A. Rear Hinge . . . . . 2 fittings (already installed)
- B. Lower Cylinder Mount 1 fitting
- C. Lower Crosstube 2 fittings
- D. Upper Crosstube 2 fittings
- E. Cylinder Crosshead 1 fitting
- F. Center Hinge 1 or 2 fitting(s)

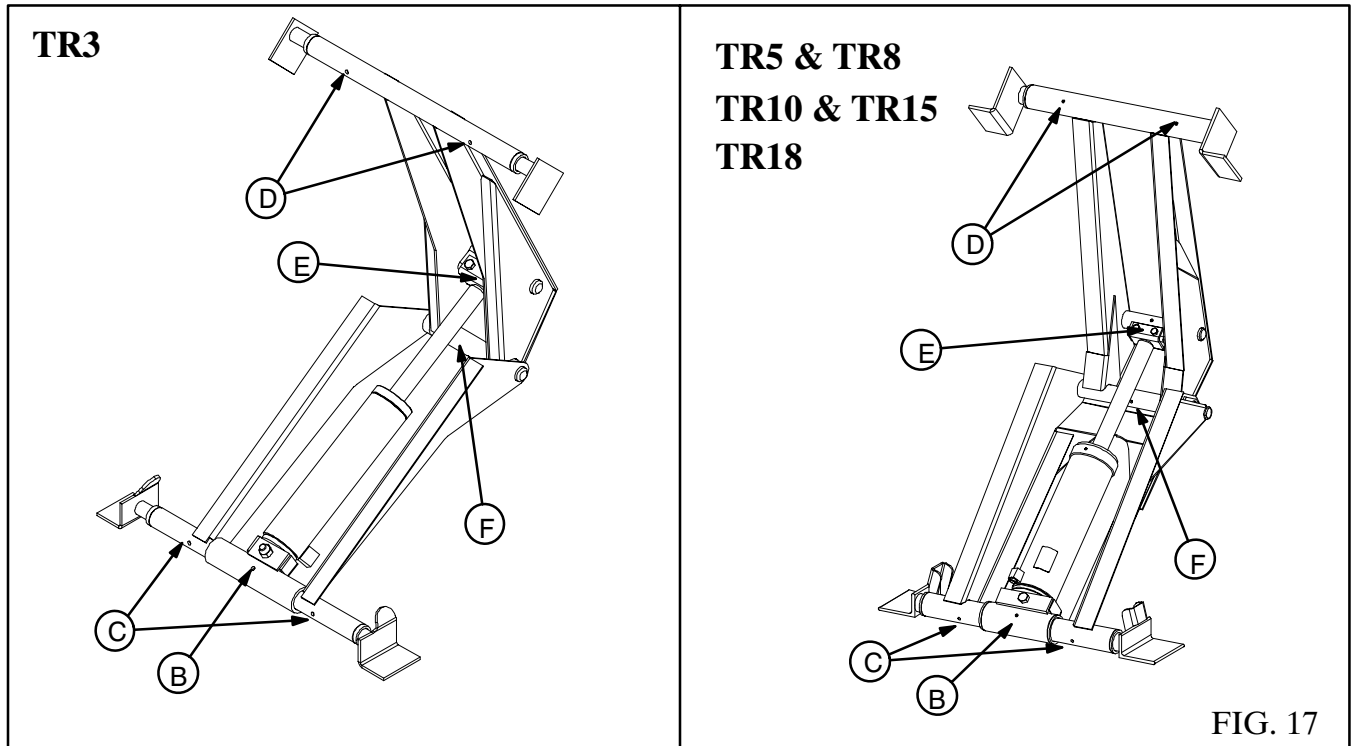
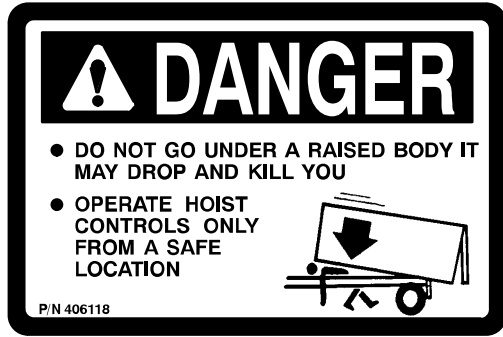

FIG. 17

# INSTALL DECALS

Mount decals in the proper places as shown in Figure 18.



406118 – Mount on the outside of the body longbeams near the front of the body (one on each side)



406117 – Mount on the longbeam on the left side

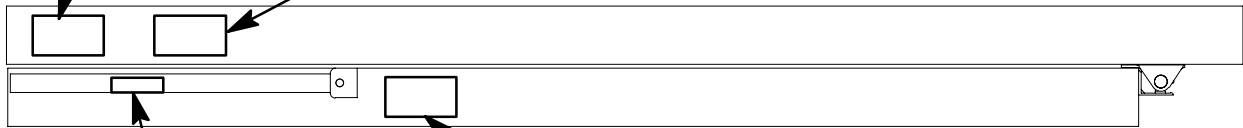

40661 – Mount on the body prop

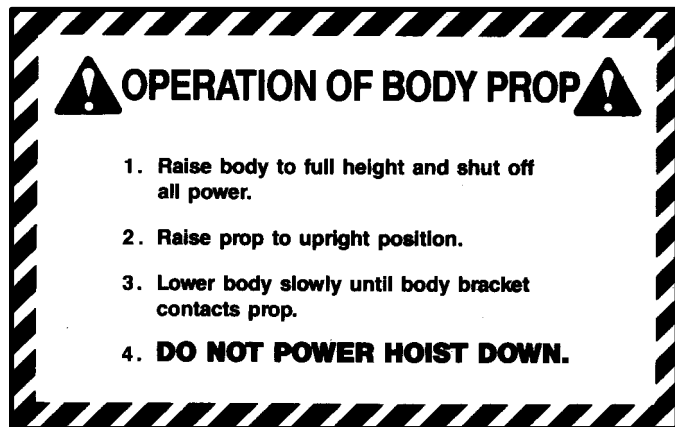

400719 – Mount on the body longbeam near the body prop

FIG. 18

## TR 3 HOIST PARTS

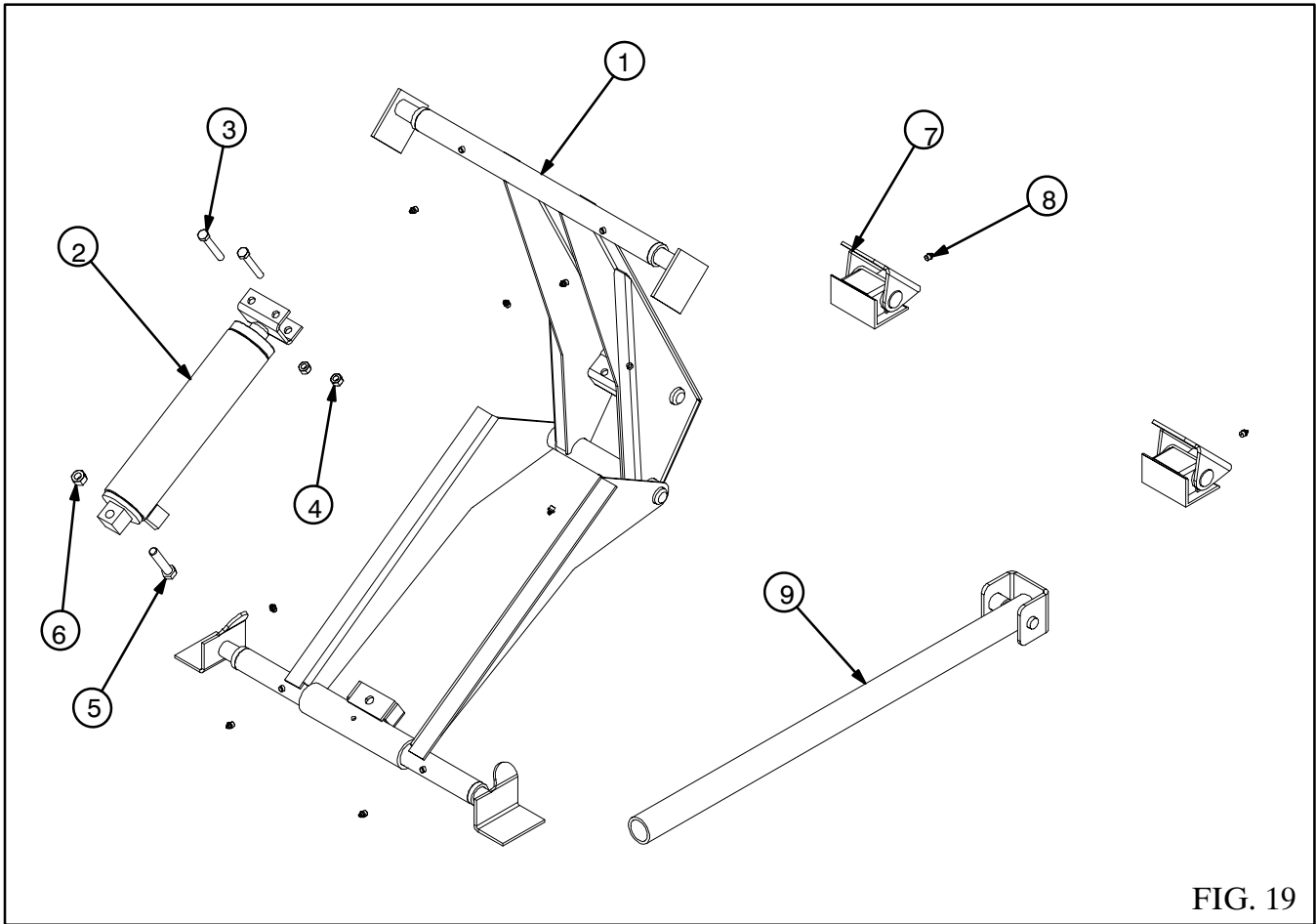
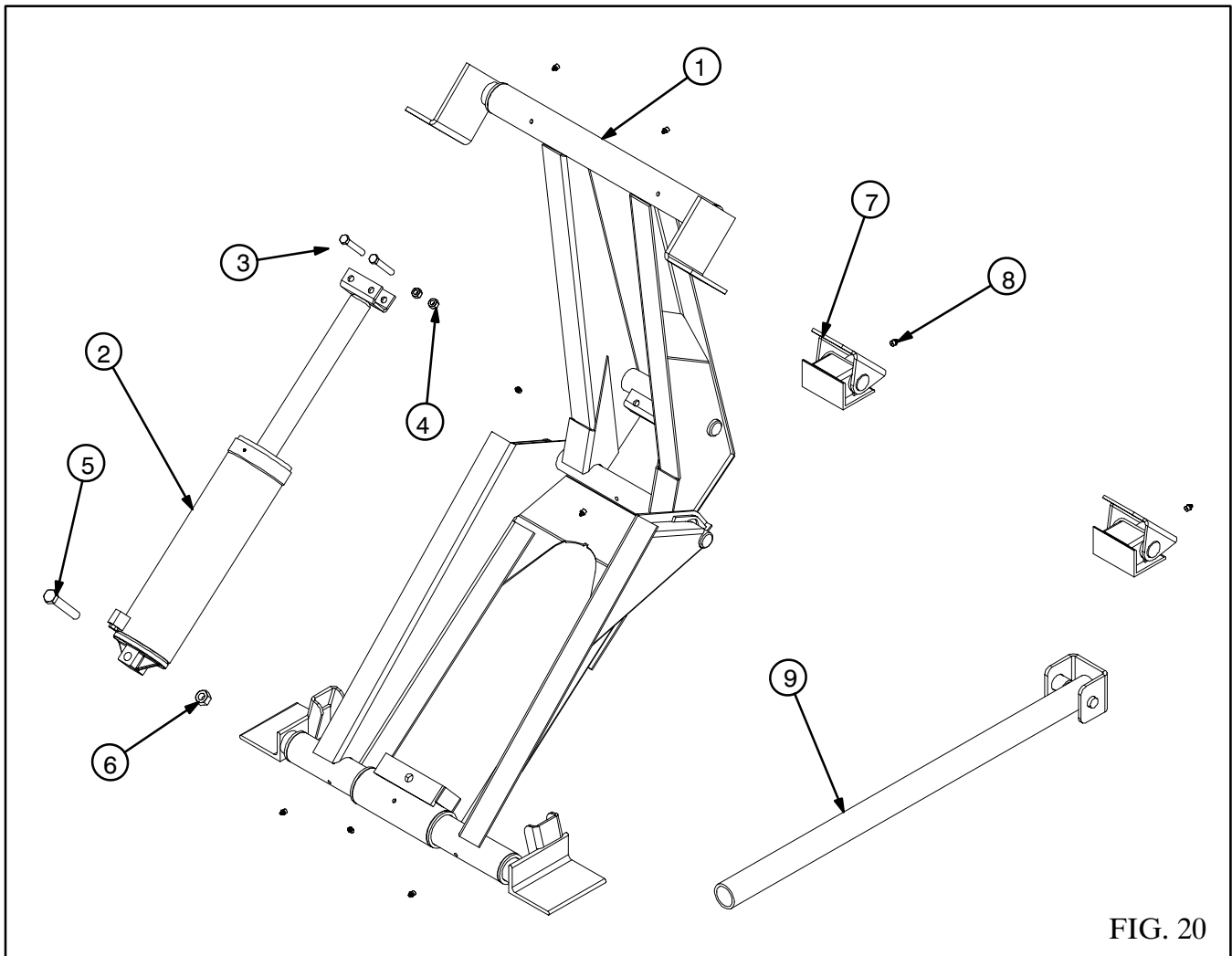

FIG. 19

ITEM	DESCRIPTION	MODEL	PART NO.	QTY.
1.	Assy Frame	TR3	151346	1
2.	Assy Cylinder	TR3	150978	1
3.	Cap Screw 1/2-13 x 3 1/4 Gr 5	TR3	401140	2
4.	Hex Lock Nut 1/2-13	TR3	401316	2
5.	Cap Screw 5/8-11 x 3 Gr 8	TR3	406061	1
6.	Hex Lock Nut 5/8-11	TR3	401585	1
7.	Assy Rear Hinge Pad - Sm	TR3	150986	2
8.	Grease Zerk 1/8 NPT	TR3	400103	9
9.	Assy Body Prop	TR3	151451	1



## TR5, TR8, TR10, TR15 & TR18 HOIST PARTS



ITEM	DESCRIPTION	MODEL TR5	MODEL TR8	MODEL TR10	MODEL TR15	MODEL TR18	QTY.
1.	Assy Frame	156995	156995	152731	153365	155548	1
2.	Assy Cylinder	105528	110304	152735	153367	155102	1
3.	Cap Screw 1/2-13 x 3 1/4 Gr 5	401140	401140	401140	401140	401140	2
4.	Hex Lock Nut 1/2-13	401316	401316	401316	401316	401316	2
5.	Cap Screw 3/4-10 x Gr 8	401237	401237	401237	401237	401237	1
6.	Hex Lock Nut 3/4-10	401226	401226	401226	401226	401226	1
7.	Assy Rear Hinge Pad	150986	150986	146157	146157	146157	2
8.	Grease Zerk 1/8 NPT	400103	400103	400103	400103	400103	9
9.	Assy Body Prop	151451	151451	151451	151451	151451	1

## TR3, TR5, TR8, TR10 & TR18 CYLINDER PARTS

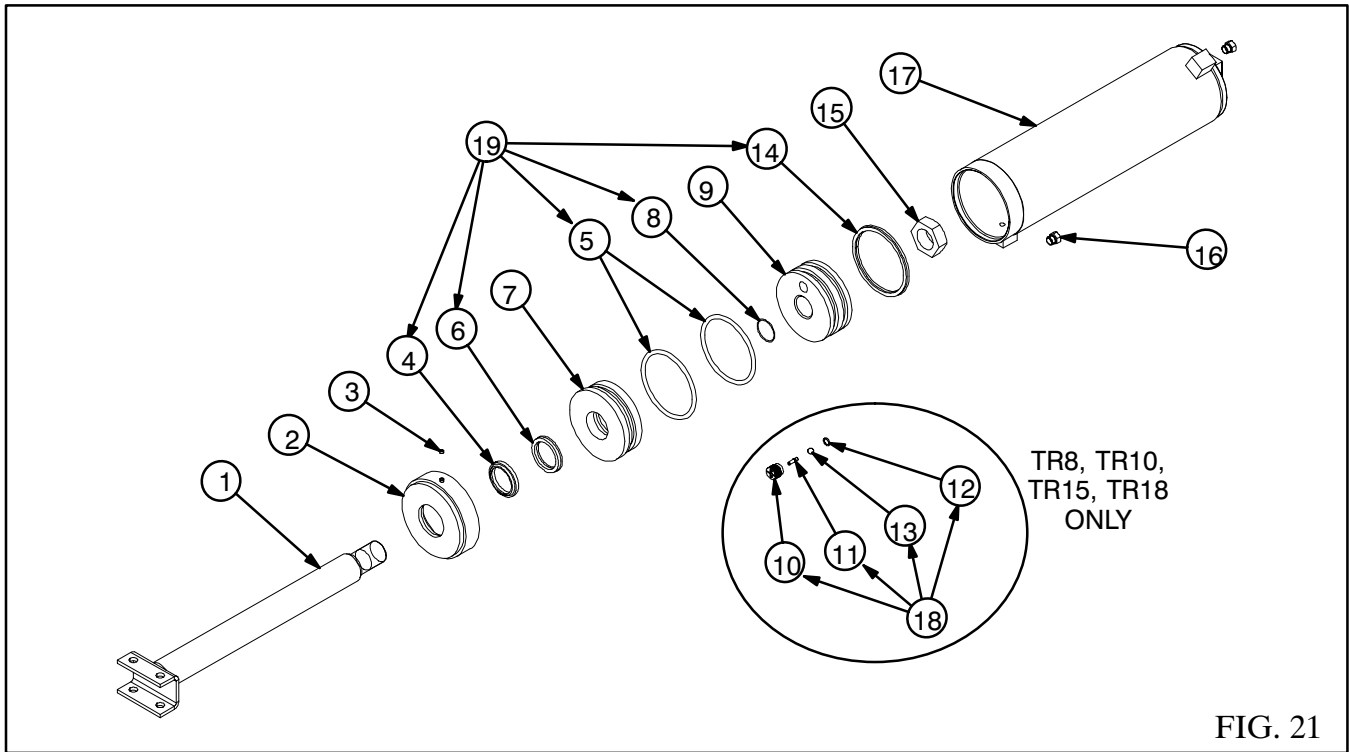

FIG. 21

ITEM	DESCRIPTION	MODEL TR3	MODEL TR5	MODEL TR8	MODEL TR10	MODEL TR15	MODEL TR18	QTY.
1.	Shaft Assy	150984	105540	110306	152737	152737	155107	1
2.	Cylinder Cap Assy		105541	104293	104293	104298	104299	1
3.	Set Screw 1/4 x 3/16 Nylon Tip		400149	400149	400149	400149	400149	1
4.	Wiper	401617	401133	400913	400913	400913	400914	1
5.	O-Ring	406041	400263	400254	400254	400258	400258	2
6.	Poly Seal	401132	401132	400253	400253	400253	400907	1
7.	Cylinder Head	276970	206279	202469	202469	205130	205141	1
8.	O-Ring	401131	401131	400255	400255	400255	400255	1
9.	Cylinder Piston	215364	206755	202461	202461	202472	202472	1
10.	Bypass Valve Body			400978	400978	400978	400978	1
11.	Bypass Valve Pin			400979	400979	400979	400979	1
12.	O-Ring 7/16			401017	401017	401017	401017	1
13.	Steel Ball 3/8 Dia			400013	400013	400013	400013	1
14.	Poly Seal	401645	400262	400252	400252	400257	400257	1
15.	Hex Jam Nut			401370	401370	401370	401370	1
16.	Plug 9/16-18 ORB	400404	400404	400404	400436	400436	400436	2

17.	Cylinder Tube Assy	150983	105539	110305	152736	153368	155106	1
18.	Bypass Valve Kit			105185	105185	105185	105185	1
19.	Seal Kit	155795	107958	107960	107960	107962	107962	1

### HYDRAULIC PARTS – SINGLE-ACTING

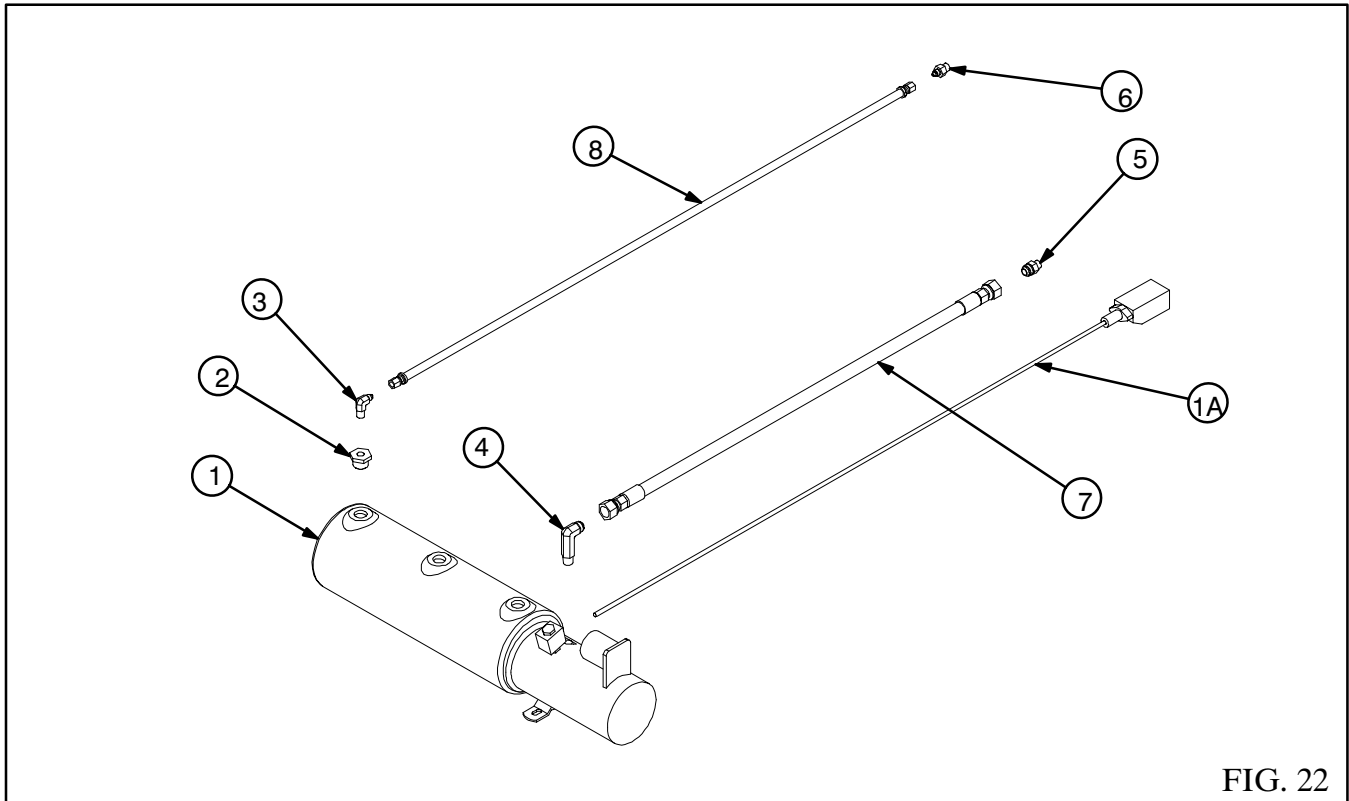

FIG. 22

ITEM	DESCRIPTION	MODEL	PART NO.	QTY.
1.	Electric Power Unit SA – 7 Qt	TR6DP, TR3, TR5, TR8 & TR10	406090	1
	Electric Power Unit SA – 20 Qt	TR15 & TR18	406119	1
1A.	Push-Button Control – 10' Cord	ALL	406157	1
2.	Bushing Hex 3/4 x 1/4	ALL	405501	1
3.	Adapter 7/16 JICM x 1/4 NPTM 90°	ALL	406151	1
4.	Adapter 3/4 JICM x 9/16 ORBM 90°	ALL	406116	1
5.	Adapter 3/4 JICM x 9/16 ORBM	TR6DP, TR3, TR5 & TR8	402516	1
	Adapter 3/4 JICM x 3/8 NPTM	TR10, TR15 & TR18	402789	1
6.	Adapter 7/16 JICM x 9/16 ORBM	TR6DP, TR3, TR5 & TR8	406152	1
	Adapter 7/16 JICM x 3/8 NPTM	TR10, TR15 & TR18	406153	1
7.	Hose 3/4 JIC x 36 SF/SF 4000	ALL	404898	1
	Hose 3/4 JIC x 42 SF/SF 4000	ALL	402489	1
	Hose 3/4 JIC x 48 SF/SF 4000	ALL	402490	1

	Hose 3/4 JIC x 54 SF/SF 4000	ALL	406120	1
	Hose 3/4 JIC x 60 SF/SF 4000	ALL	402517	1
	Hose 3/4 JIC x 66 SF/SF 4000	ALL	403311	1
	Hose 3/4 JIC x 72 SF/SF 4000	ALL	404906	1
	Hose 3/4 JIC x 78 SF/SF 4000	ALL	406121	1
	Hose 3/4 JIC x 84 SF/SF 4000	ALL	406122	1
	Hose 3/4 JIC x 90 SF/SF 4000	ALL	406128	1
	Hose 3/4 JIC x 96 SF/SF 4000	ALL	406129	1
8.	Hose 7/16 JIC x 48 SF/SF 250	ALL	406130	1
	Hose 7/16 JIC x 54 SF/SF 250	ALL	406139	1
	Hose 7/16 JIC x 60 SF/SF 250	ALL	406140	1
	Hose 7/16 JIC x 66 SF/SF 250	ALL	406141	1
	Hose 7/16 JIC x 72 SF/SF 250	ALL	406142	1
	Hose 7/16 JIC x 78 SF/SF 250	ALL	406143	1
	Hose 7/16 JIC x 84 SF/SF 250	ALL	406144	1
	Hose 7/16 JIC x 90 SF/SF 250	ALL	406145	1
	Hose 7/16 JIC x 96 SF/SF 250	ALL	406146	1

## HYDRAULIC PARTS – DOUBLE-ACTING

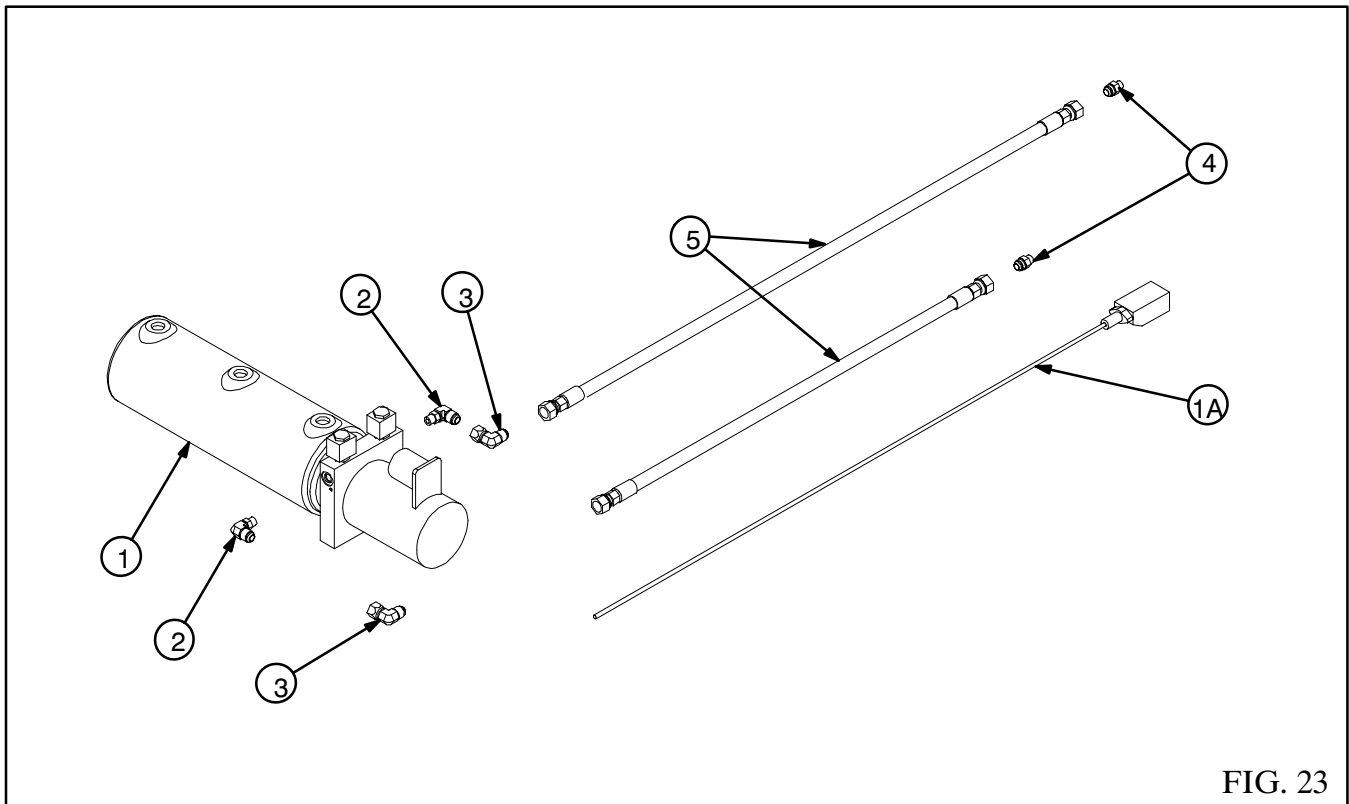

FIG. 23

ITEM	DESCRIPTION	MODEL	PART NO.	QTY.
1.	Electric Power Unit DA – 7 Qt	ALL	406598	1
1A.	Push-Button Control – 10' Cord	ALL	406599	1
2.	Adapter 9/16 ORBM X 3/4 JICF 90°	ALL	403447	1
3.	Adapter 3/4 JICM x 3/4 JICF 90°	ALL	403448	1
4.	Adapter 3/4 JICM x 9/16 ORBM	TR6DP, TR3, TR5 & TR8	402516	2
	Adapter 3/4 JICM x 3/8 NPTM	TR10, TR15 & TR18	402789	2
5.	Hose 3/4 JIC x 36 SF/SF 4000	ALL	404898	5
	Hose 3/4 JIC x 42 SF/SF 4000	ALL	402489	1
	Hose 3/4 JIC x 48 SF/SF 4000	ALL	402490	1
	Hose 3/4 JIC x 54 SF/SF 4000	ALL	406120	1
	Hose 3/4 JIC x 60 SF/SF 4000	ALL	402517	1
	Hose 3/4 JIC x 66 SF/SF 4000	ALL	403311	1
	Hose 3/4 JIC x 72 SF/SF 4000	ALL	404906	1
	Hose 3/4 JIC x 78 SF/SF 4000	ALL	406121	1
	Hose 3/4 JIC x 84 SF/SF 4000	ALL	406122	1
	Hose 3/4 JIC x 90 SF/SF 4000	ALL	406128	1
	Hose 3/4 JIC x 96 SF/SF 4000	ALL	406129	1

## SPECIFICATIONS

Hoist Model	Cylinder Bore	Cylinder Stroke	Cylinder Shaft	Operating Pressure
TR3	3 1/4"	11"	1 1/2"	3250 PSI
TR5	4"	15 1/4"	1 1/2"	3250 PSI
TR8	5"	15 1/4"	2"	3250 PSI
TR10	5"	20 11/16"	2"	3250 PSI
TR15	6"	20 11/16"	2"	3250 PSI
TR18	6"	29 5/16"	2 1/4"	3250 PSI

### CAPACITY FORMULA

The capacity of the Colt trailer hoists can be calculated using the following steps.

1. Measure the distance, in inches, from the center of the rear hinge to the center of the body. Call this "A".
2. Measure the distance, in inches from the center of the rear hinge to the forward crosstube on the hoist. Call this "D". (See Figures 2, 3 & 4 for "D" dimensions for the various models.)
3. For Model TR3, multiply "D" by 2.76.  
For Model TR5, multiply "D" by 3.87.  
For Model TR8, multiply "D" by 6.05.  
For Model TR10, multiply "D" by 6.16.  
For Model TR15, multiply "D" by 8.87.  
For Model TR18, multiply "D" by 8.75.
4. Divide the result of Step 3 by "A". This is the capacity in tons for an evenly distributed load (over the whole length of the body) and includes the weight of the body.

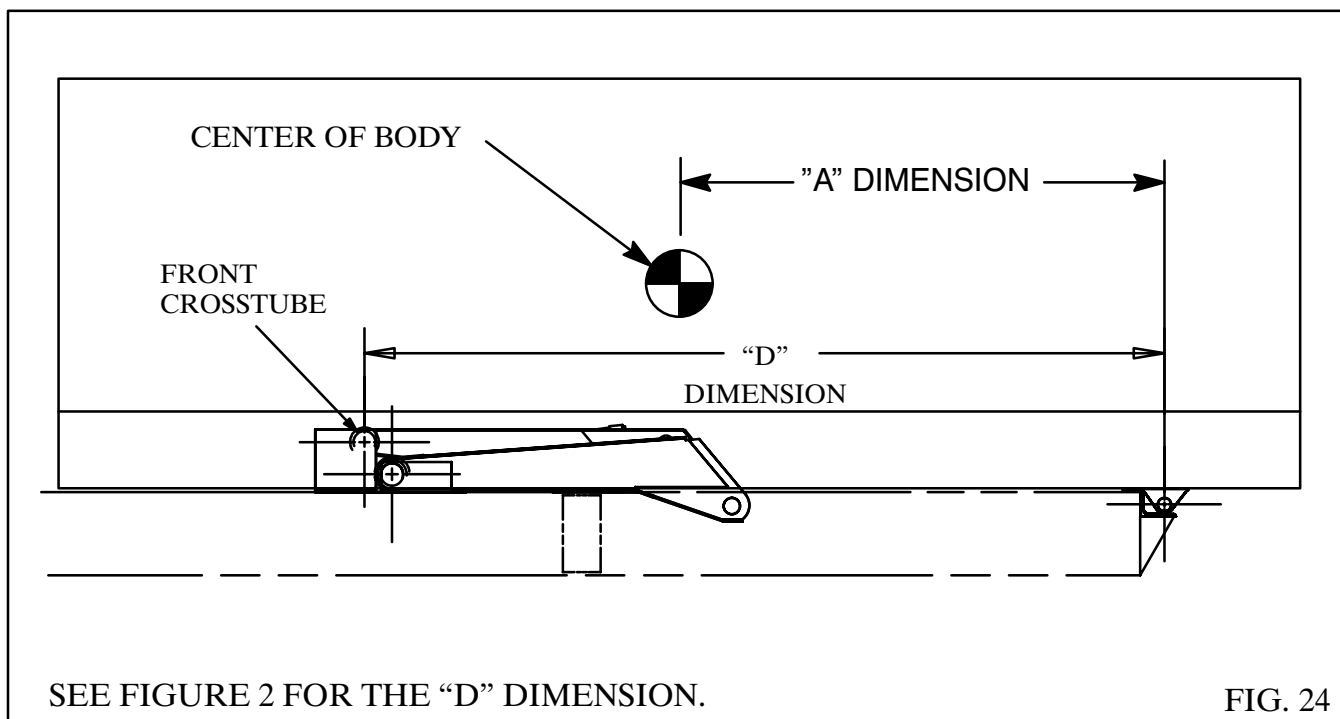

# NOTES

---

*SPECIALLY DESIGNED – WITH QUALITY IN MIND*

**WARRANTY**

- This Colt Hoist Warranty covers new products for a period of one (1) year after the date of the hoist manufacturer's invoice.
- This warranty covers Colt Hoist products for defective material and/or workmanship at a rate of 100%.
- This warranty is limited to product manufactured by Crysteel Mfg. and does not cover modifications. Crysteel will not assume responsibility for travel, loss of use, or downtime expenses. This warranty is void if the product has been obviously abused, subjected to other than intended usage, or modified from its original design.



**CRYTEEL MANUFACTURING, INC.**

P.O. Box 178 52182 Ember Road  
Lake Crystal, MN 56055

1902 Route 57 South  
Fulton, NY 13069

(507) 726-2728 (800) 533-0494