



Website: [www.TBEI.com](http://www.TBEI.com)  
E-mail: [sales@TBEI.com](mailto:sales@TBEI.com)

# **CRYSTEEL'S LO-BOY TRUCK HOIST**



***THIS MANUAL MUST BE INCLUDED WITH THE VEHICLE  
AFTER COMPLETING THE INSTALLATION.***

Web Site  
[www.crysteel.com](http://www.crysteel.com)

E-Mail  
[crysteel@tbei.com](mailto:crysteel@tbei.com)

Phone (507) 726-2728  
Toll Free (800) 533-0494

DATE PURCHASED \_\_\_\_\_

HOIST SERIAL NUMBER \_\_\_\_\_

CYLINDER SERIAL NUMBER \_\_\_\_\_

DEALER \_\_\_\_\_

ADDRESS \_\_\_\_\_

PHONE \_\_\_\_\_

## FOREWORD

Crysteel's LoBoy hoists have been designed for use on single-axle trucks with cab-to-axle dimensions of 60 to 150 inches for use with bodies of 8 through 18 feet in length and on tandem axle trucks with cab-to-tandem center dimensions of 102 to 126 inches for use with bodies from 14 to 18 feet in length. Bodies normally used with these hoists are grain bodies and platforms. This manual contains the information needed for the proper installation and operation of these hoists.

These instructions are for installing and maintaining all models of LoBoy hoists. With proper installation, use, and regular maintenance, Crysteel's LoBoy truck hoists will give many years of trouble free service.

When ordering parts, be sure to give serial number of hoist and cylinder. The serial number of the hoist is stamped into the hoist frame near the base end of the cylinder. The serial number of the cylinder is stamped on the barrel of the cylinder near the base. For future reference, copy these numbers NOW in the space provided above. Order parts by number and description as given in the parts listing in this manual.

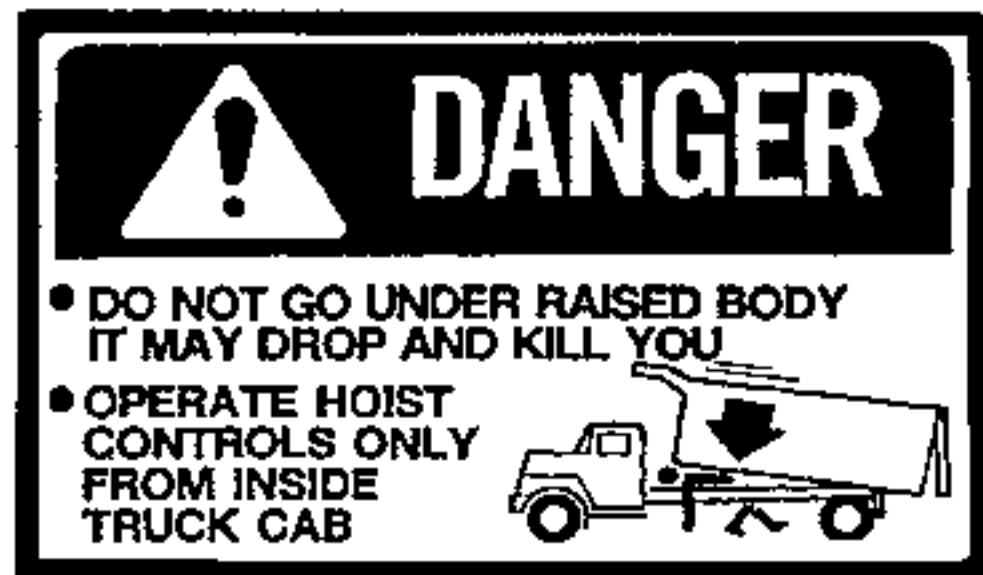

## OPERATION AND USE

1. Engage PTO from cab and adjust engine speed to fast idle.
2. ALWAYS operate the hoist from inside the cab of the truck.
3. If the hydraulic hose connections are correct, the hoist should raise when the hoist control lever is pulled back, hold when the lever is in the center detent, and lower when the lever is pushed forward.
4. To raise the hoist, pull the control lever back. To hold the body in a raised position, place the control lever in its center detent position. To lower the hoist, push the control lever forward.
5. ALWAYS return the hoist control lever to its center detent position after each use.
6. When the hoist cylinder reaches the end of the stroke, oil will flow through the automatic bypass valve built into the piston inside the cylinder and return to the reservoir.
7. It is advisable to run the PTO to "power down" or lower the hoist because this will act as an hydraulic lock to hold the hoist in the lowered position. It is not necessary to do this, however, because the reservoir has sufficient capacity whether or not the hoist is powered down. You will benefit from the advantages of the double acting hoist only if you power down.
8. To make use of the hydraulic lock feature, place the hoist control lever in the center hold position after the hoist is powered down. This places the pressure on the valve, where it belongs, not on the pump.
9. DO NOT LEAVE THE PTO IN GEAR WHILE TRANSPORTING. THIS CAN CAUSE SEVERE DAMAGE TO THE PTO OR HYDRAULIC PUMP.
10. The hydraulic system should be drained, flushed and refilled with proper hydraulic fluid at regular intervals. CAUTION: NEVER use hydraulic BRAKE FLUID in the hydraulic system.
11. After adding or replacing the hydraulic fluid, cycle the hoist several times to remove air from the cylinders and hydraulic hoses.

## SOME DO'S AND DON'TS FOR SAFE AND LONG SERVICE

1. Use the proper hydraulic fluid. KEEP IT CLEAN. Remember to change it regularly.
2. Lubricate all grease fittings every 100 cycles or every two months. Infrequent or insufficient lubrication will cause hoist failure and possibly injury or death.
3. ALWAYS carefully block up the body, using the body prop, before working under it.
4. Do not "race" the engine when unloading.
5. Do not load the hoist beyond its capacity.
6. DO NOT tamper with the hydraulic relief valve. This will void the warranty. It can cause severe damage to the hoist and cylinder.
7. Never leave the PTO in gear while transporting. It could ruin the hydraulic pump, the PTO or the transmission.
8. Check all bolts and fittings regularly. Keep them tight. See table on page 4 for torque values.
9. Always operate hoist on a firm and level surface.
10. Always make sure area around truck is clear and safe for hoist operation and dumping.

## TABLE OF CONTENTS



FOREWORD	2
SOME DO'S AND DON'TS FOR SAFE AND LONG SERVICE OPERATION AND USE	3
LOCATE AND INSTALL REAR HINGE	6
LOCATE HOIST	7
MOUNT HOIST FRAME	8
HYDRAULIC SYSTEMS	8
INSTALL GEAR PUMP - BERT, CHARLIE & DANIEL	8
INSTALL GEAR PUMP - DAVID, ERNIE & FLOYD	9
MOUNT RESERVOIR/VALVE ASSEMBLY - BERT, CHARLIE & DANIEL	9
MOUNT RESERVOIR/VALVE ASSEMBLY - DAVID, ERNIE & FLOYD	10
INSTALL HOIST CONTROL	11
INSTALL HOSES - BERT, CHARLIE & DANIEL	12
INSTALL HOSES - DAVID, ERNIE & FLOYD	13
ADD HYDRAULIC FLUID	14
ELECTRIC POWER UNIT MOUNTING - GENERAL	15
INSTALL HOSES - SINGLE-ACTING	16
INSTALL HOSES - DOUBLE-ACTING	17
ELECTRIC DOUBLE-ACTING	17
ADD HYDRAULIC FLUID	18
MOUNT BODY	19
INSTALL BODY GUIDE PLATES	19
INSTALL BODY PROP	20
INSTALL GREASE ZERKS AND LUBRICATE	21
MOUNT DECALS	22
HOIST PARTS - BERT, CHARLIE, DANIEL, DAVID, ERNIE & FLOYD	23
CYLINDER PARTS	25
HYDRAULIC SYSTEM PARTS - BERT, CHARLIE, DANIEL	26
HYDRAULIC SYSTEM PARTS - DAVID, ERNIE, FLOYD	29
CAPACITY FORMULA	32
SPECIFICATIONS	32

## INSTALLATION INSTRUCTIONS





### GENERAL INFORMATION

It is a good idea to look through these installation instructions before beginning to mount the hoist and hydraulic system.

When welding, protect the truck's electrical, air and brake systems by disconnecting, removing or covering. Tighten all nuts and bolts to a consistent level. Use the following table for torque values.

Size	Grade 2 Torque	Grade 5 Torque	Grade 8 Torque
			
1/4-20	3-4 lb-ft	6-7 lb-ft	10-11 lb-ft
1/4-28	4-5 lb-ft	8-9 lb-ft	11-12 lb-ft
5/16-18	8-9 lb-ft	14-15 lb-ft	21-22 lb-ft
5/16-24	9-10 lb-ft	15-16 lb-ft	21-22 lb-ft
3/8-16	17-18 lb-ft	24-26 lb-ft	37-40 lb-ft
3/8-24	19-20 lb-ft	28-30 lb-ft	40-43 lb-ft
1/2-13	38-42 lb-ft	60-65 lb-ft	90-100 lb-ft
1/2-20	43-47 lb-ft	70-75 lb-ft	95-105 lb-ft
5/8-11	75-80 lb-ft	122-130 lb-ft	180-190 lb-ft
5/8-18	85-90 lb-ft	145-150 lb-ft	200-210 lb-ft
3/4-10	132-140 lb-ft	220-230 lb-ft	315-330 lb-ft
3/4-16	152-160 lb-ft	250-260 lb-ft	355-370 lb-ft

The following abbreviations are used in describing hydraulic fittings.

ORBM	O-Ring Boss - Male Thread	
NPTM	Pipe - Male Thread	
NPTF	Pipe - Female Thread	
JICM	JIC 37° - Male Thread	
JICF	JIC 37° - Female Thread	

## LOCATE AND INSTALL REAR HINGE

On single-axle trucks, the rear hinge must be located as close as possible behind the rear spring hanger. This will be 32 to 36 inches behind the center of the rear axle. On tandem axle trucks the center of the rear hinge should be located 42 to 50 inches behind the center of the rear tandems. Mark the rear of the truck frame for notching as shown in Figure 1. Notch the truck frame as marked. Make sure the rear hinge is square with the truck frame and at the correct height. The top surface of the rear hinge bracket should be flush with the top of the angle mounting brackets of the hoist frame as shown in Figure 1. Securely weld the rear hinge to the truck frame. Cap the ends of the truck frame under the rear hinge. Weld the capping plates to the ends of the truck frame and to the bottom side of the rear hinge angle.

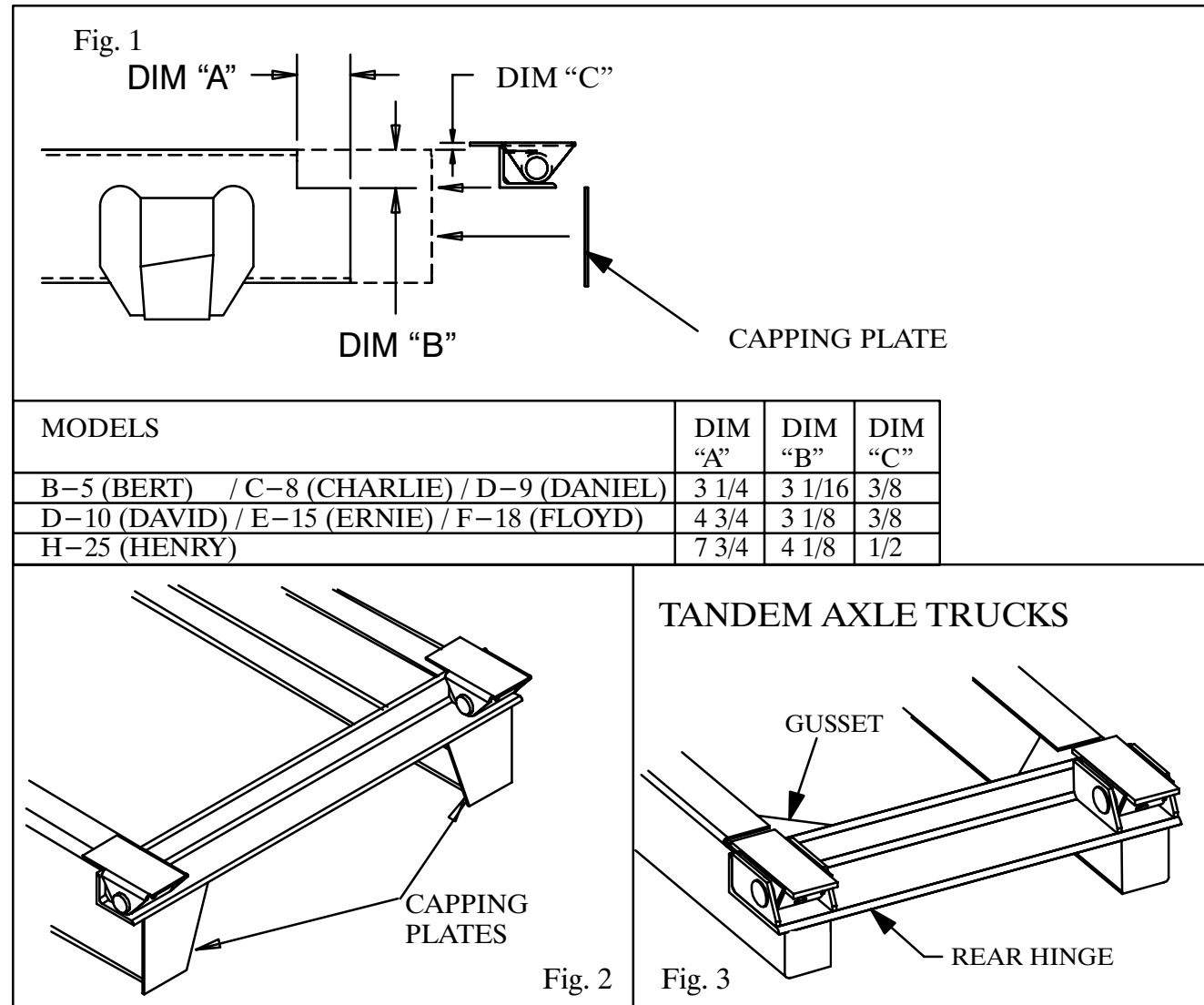

On tandem-axle trucks, place the gussets in the corners formed by the truck frame rail and the rear hinge frame angle. Raise the front end of the gusset so it touches the top flange of the truck frame rail. Be sure that the gusset does not interfere with the rear hinge operation. Securely weld the gussets to the rear hinge, the truck frame rail and the top flange of the truck frame rail.

**WARNING! LOCATING THE REAR HINGE FARTHER BACK THAN RECOMMENDED MAY CAUSE UNDUE STRESS IN THE TRUCK FRAME, AND MAY CAUSE INSTABILITY DURING THE LIFTING CYCLE!**

## LOCATE HOIST

Determine where to mount the hoist on the truck. Please refer to the chart in Fig. 4 for the relationship between dump angle and "D" dimension. Measure forward from the center of the rear hinge pin and mark, on the truck frame, the location of the front cross-tube of the hoist frame. Place the hoist on the truck frame and clamp the hoist pivot pads to the truck frame. The back end of the hoist must be supported by a cross-member in the truck frame. The top of this crossmember may be up to 1" below the top of the truck frame. The "CM" dimension shows the location for this crossmember. Make sure the hoist frame is centered on and square with the truck frame.

If desired, the hoist can be turned end for end for a 'Reverse' mount. This does not affect the lifting capacity.

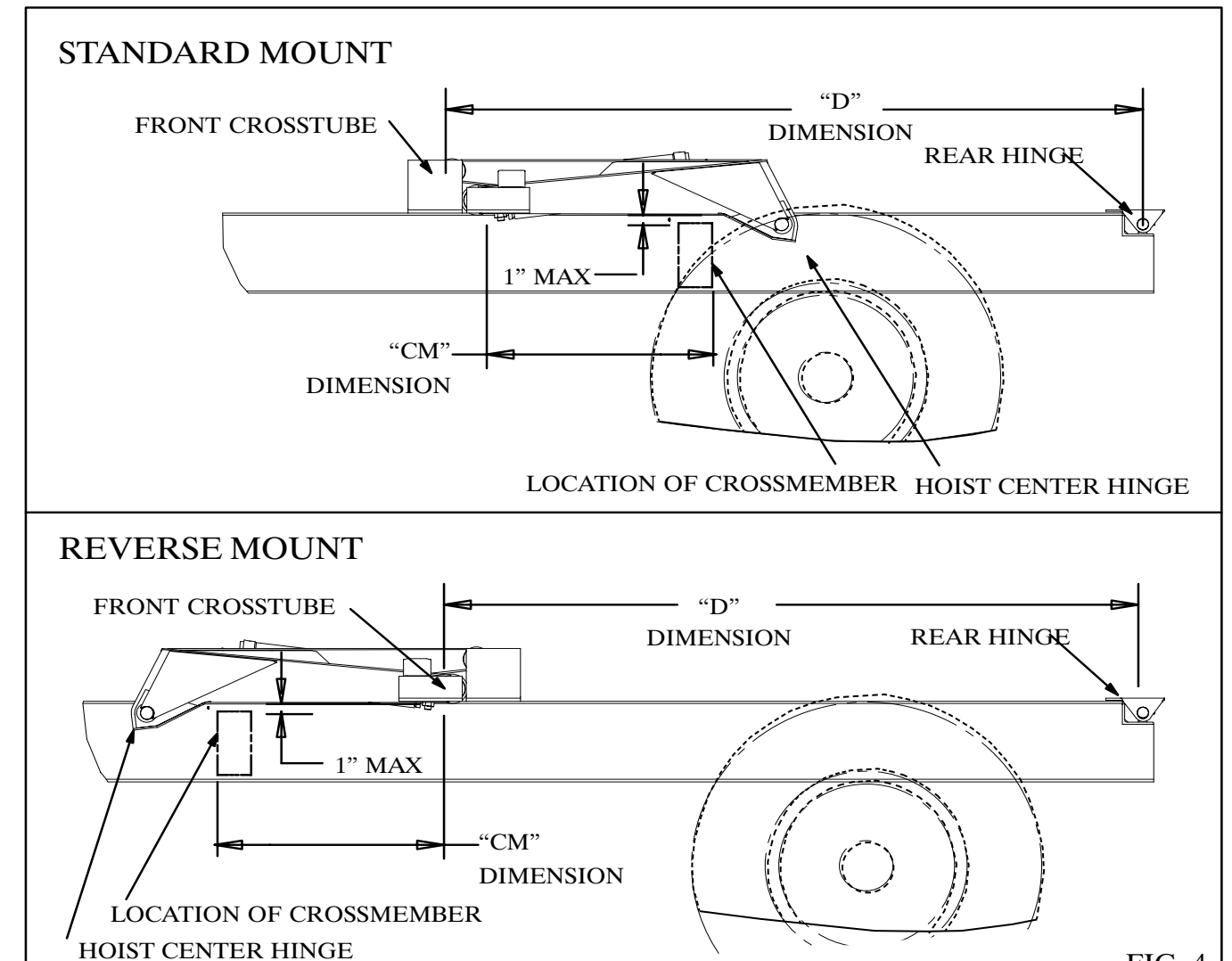
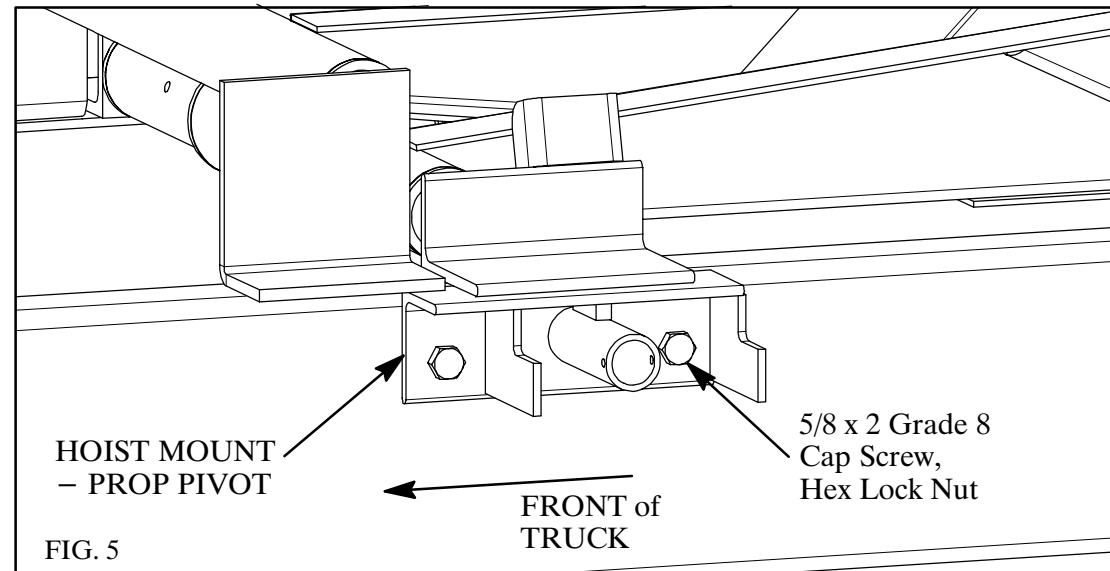

FIG. 4

DIMENSIONS	"D"					"CM"
	DUMP ANGLE	35°	40°	45°	50°	
B-5 (BERT), C-8 (CHARLIE) & D-9 (DANIEL)	97 1/2"	86 3/4"	77 3/4"	70 1/2"	64 3/4"	30"
D-10 (DAVID) & E-15 (ERNIE)	122"	108"	96"	88"	81"	34"
F-18 (FLOYD)	169"	149"	133"	120"	111"	43"

## MOUNT HOIST FRAME

The hoist pivot pads must rest flat on the truck frame. If the hoist pivot pads sit on rivet heads in the truck frame, either move the hoist or drill holes in the pivot pads to clear the rivets. On the driver's side, clamp the hoist mount/prop pivot the lower hoist pivot pad and to the outside of the truck frame. On the passenger side, clamp a hoist mounting angle to the lower hoist pivot pad and to the outside of the truck frame. Mark the truck frame for drilling. See Figure 5.



**CAUTION: BE CAREFUL OF BRAKELINES, WIRING, ETC. INSIDE THE TRUCK FRAME WHEN DRILLING THE TRUCK FRAME.**

Drill 21/32 diameter holes in the truck frame using the hoist mounting angles as guides. Bolt the prop pivot and mounting angle to the truck frame using 5/8 x 2 hex bolts and hex lock nuts, tightening to 180 to 190 lb-ft. Securely weld the lower hoist pivot pads to the mounting angles. **DO NOT WELD THE HOIST PIVOT PADS TO THE TRUCK FRAME!** Remove the clamps.

## HYDRAULIC SYSTEMS

Crysteel offers PTO driven, gear pump hydraulic systems for use with all models of LoBoy hoists. Crysteel also offers electric power units, both single- and double-acting, for all models except H-25 (Henry). Mounting instructions can be found on the pages shown:

PTO driven Gear Pump with Remote Reservoir/Valve	Page 8
Electric Pumps - General	Page 15
Electric Pumps - Single-Acting	Page 16
Electric Pumps - Double-Acting	Page 17

## INSTALL GEAR PUMP - B-5 (BERT), C-8 (CHARLIE) & D-9 (DANIEL)

The gear pump has an SAE 'A' mounting configuration, an 11-tooth splined shaft and a two-bolt mounting flange, and is assembled for counterclockwise rotation. Note: This pump will mount directly to Chelsea's output type 'AD' or Muncie's output type 'T'. Crysteel Manufacturing recommends a PTO ratio of 100-120%. This assures a minimum pump operating speed of 600 RPM. **CHECK THE ROTATION OF THE PTO!** If it is opposite of the engine, then the pump can be used as it is. If the PTO rotation is the same as the engine, then the pump will need to be reversed. (See instructions included with the pump.) Bolt the gear pump to the PTO output flange using 3/8 x 1" cap screws and lock washers.

## INSTALL GEAR PUMP - D-10 (DAVID), E-15 (ERNIE) & F-18 (FLOYD)

The gear pump for the D-10 (David), E-15 (Ernie) and F-18 (Floyd) hoists has an SAE 'B' mounting configuration, a 13 tooth splined shaft and a four-bolt mounting flange, and is assembled for rotation in either direction. NOTE: This pump will mount directly to Chelsea's output type 'XK' or Muncie's output type 'D'. Crysteel Manufacturing recommends a PTO ratio of 100-120%. This assures a minimum pump operating speed of 600 RPM. Bolt the gear pump to the PTO output flange using 1/2 x 1 1/4 cap screws and lock washers.

## MOUNT RESERVOIR/VALVE ASSEMBLY - B-5 (BERT), C-8 (CHARLIE) & D-9 (DANIEL)

Determine which side of the truck to mount the reservoir/valve assembly. The same side as the PTO opening on the transmission would be ideal. Using 3/8 x 1" cap screws, flat washers and hex lock nuts, bolt the reservoir mounting angles to the reservoir/valve assembly so the exposed end of the valve spool is toward the cab (See Fig. 7). This makes it much easier to connect the valve control cable to the valve. Place this assembly against the outside of the truck frame on the same side as the pump. Mark the truck frame for drilling using the mounting angles as guides. Make sure there is enough clearance for hot exhaust pipes. **THE ENGINE EXHAUST MUST NEVER BLOW DIRECTLY ONTO THE RESERVOIR/VALVE ASSEMBLY.**

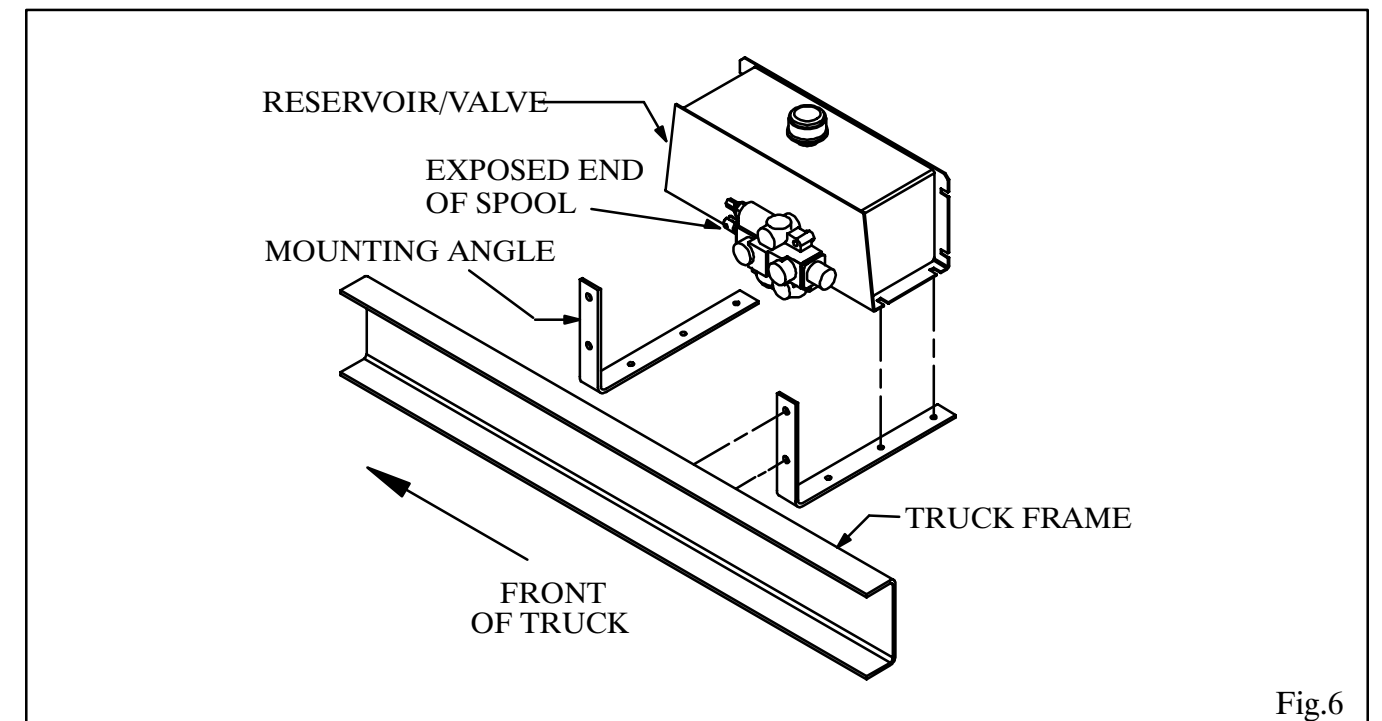

**CAUTION: BE CAREFUL OF BRAKELINES, WIRING, ETC. INSIDE THE TRUCK FRAME WHEN DRILLING THE TRUCK FRAME.**

Drill 17/32" holes in the truck frame and bolt the reservoir/valve assembly in place using 1/2 x 2" cap screws and hex lock nuts, tightening to 90 to 100 lb-ft.

### MOUNT RESERVOIR/VALVE ASSEMBLY - D-10 (DAVID), E-15 (ERNIE) & F-18 (FLOYD)

The reservoir/valve assembly should be mounted on the same side of the truck as the pump with the exposed end of the valve spool toward the front. Bolt the mounting angles to the reservoir/valve assembly using 3/8 x 1 cap screws, flat washers and hex lock nuts, tightening to 24 to 26 lb-ft. Place the reservoir/valve assembly inside the truck frame and raise it as high as possible. See Figure 5. (There is no drive line to align and the reservoir should be higher than the pump for reliable performance.) Make sure there is enough clearance for the truck drive line and hot exhaust pipes. **THE ENGINE EXHAUST MUST NEVER BLOW DIRECTLY ONTO THE RESERVOIR/VALVE ASSEMBLY.** Clamp the mounting angles to the truck frame and mark the truck frame for drilling using the pump mounting angles as guides.

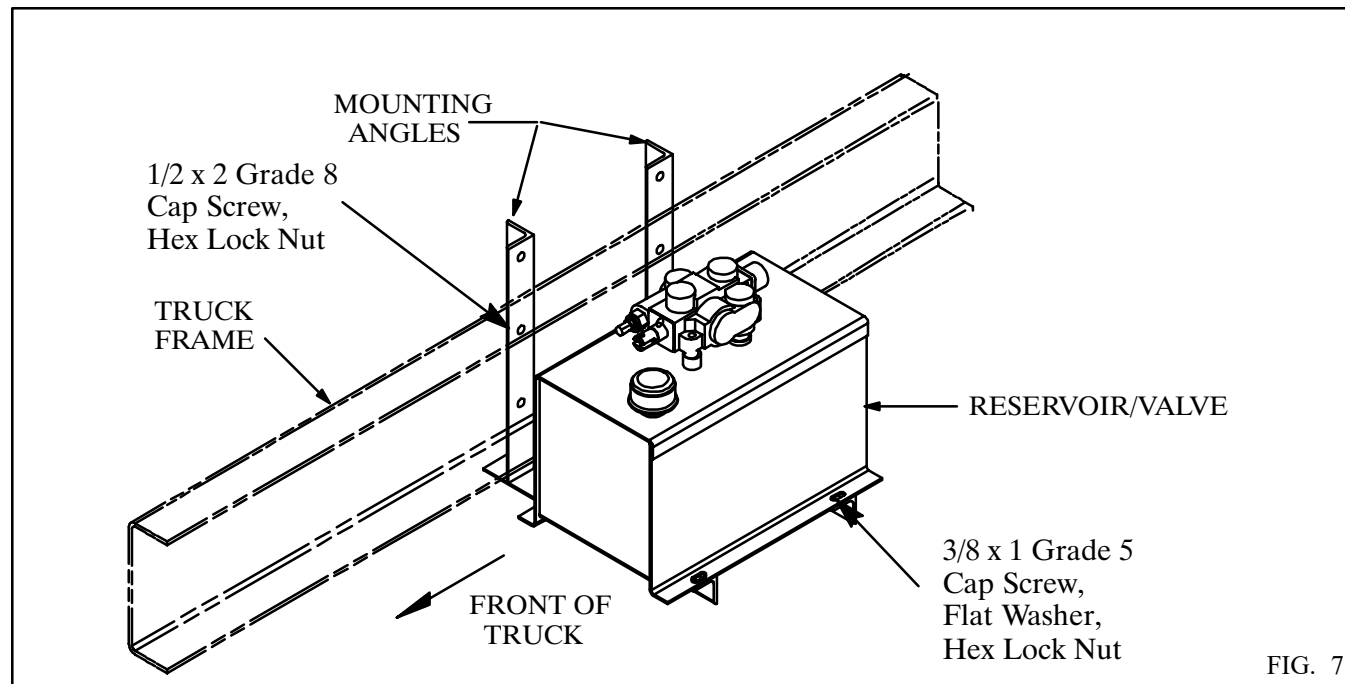

FIG. 7

**CAUTION: BE CAREFUL OF BRAKELINES, WIRING, ETC. INSIDE THE TRUCK FRAME WHEN DRILLING THE TRUCK FRAME.**

Drill 17/32" holes in the truck frame and bolt the reservoir/valve assembly in place using 1/2 x 2" cap screws and hex lock nuts, tightening to 90 to 100 lb-ft.

### INSTALL HOIST CONTROL

Mount the Hoist Control decal on the pedestal taking care to align the holes for the PTO cable and indicator light. Temporarily assemble the valve control head to the pedestal using 5/16 x 2 1/2 machine screws and hex nuts. Place this assembly on the floor of the cab. The pedestal and valve control should angle forward. This makes it convenient for the operator to pull the hoist control lever back to raise the hoist. Make sure there is enough room to operate the valve control and gear shift lever and to adjust the seat. Check below the floor for obstructions and cable routing. Relocate the valve control if necessary. Mark the floor using the pedestal as a template and drill 11/32" holes for the mounting screws and a 3/4" hole for the control cable. Assemble the control cable to the valve control head and assemble the valve control head and cover to the pedestal using 5/16 x 2 1/2 machine screws and hex lock nuts. Insert the control cable through the hole in the floor and mount the pedestal to the floor using 5/16 x 1/2 hex head cap screws, clamping plate (under the floor) and hex lock nuts. Make sure the valve control lever is in its center detent position. Keep the control cable away from hot exhaust pipes and rotating drive shafts. The control cable should not have any sharp bends or kinks in it (these will make the control harder to operate).

Install the 3/4" hex jam nut onto the valve end of the control cable and turn it past the threads. Insert the end of the cable through the bonnet clamp. Install the bonnet onto the control cable and turn it past the threads also. Install the 1/4" hex jam nut and terminal eye on the core rod of the cable; lock the terminal eye to the core rod of the cable using the hex jam nut. Place the terminal eye in the slot of the valve spool; insert the short pin through the valve spool and terminal eye and secure it in place with the 'E' ring. Thread the bonnet onto the end of the cable so it firmly touches the end of the valve. (Do not over- or under-tighten the bonnet as either would move the valve spool out of its neutral position.) Remove two cap screws from opposite corners of the seal retainer plate. Slide the bonnet clamp onto the bonnet and secure it to the valve using the 1/4 x 1 1/4 cap screws, lock washers and flat washers. Lock the bonnet to the cable using the 3/4" hex jam nut. (See Fig. 8.)

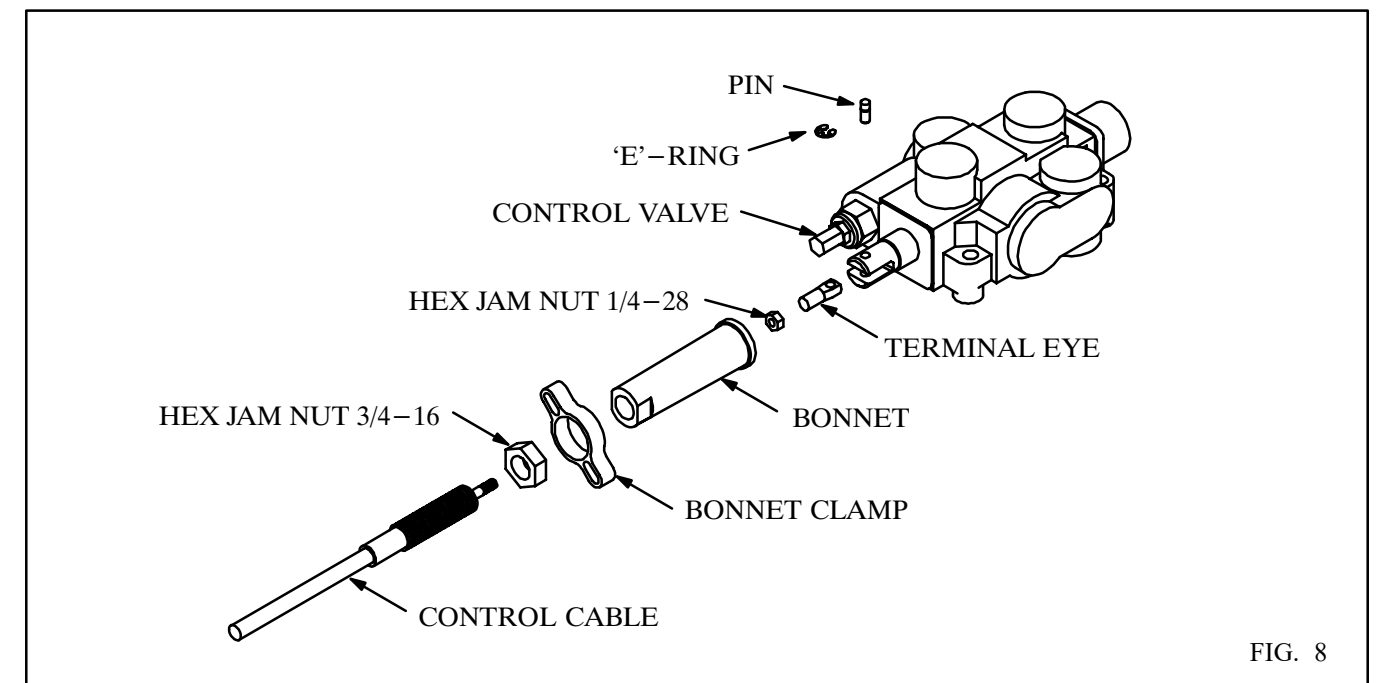
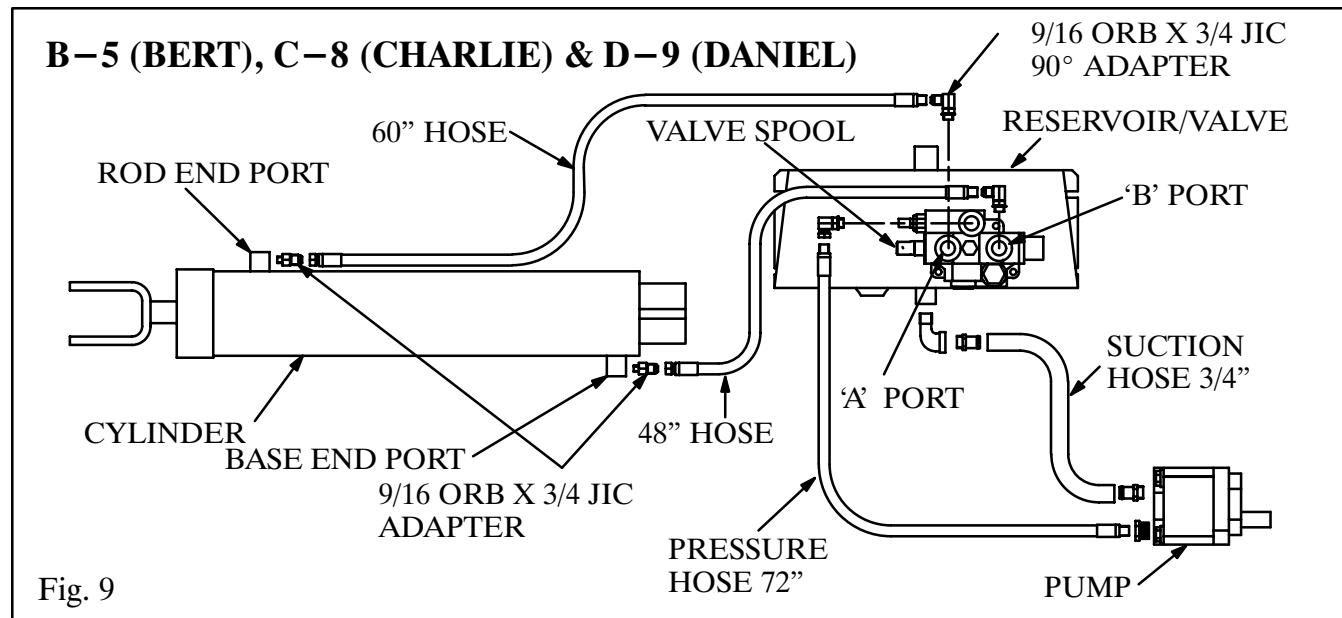

FIG. 8

## INSTALL HOSES - B-5 (BERT), C-8 (CHARLIE) & D-9 (DANIEL)

Study Fig. 9 very carefully before connecting hoses. Install a 90° street elbow and a 3/4" hose barb in the suction port on the bottom of the reservoir. Install a 1 1/16 ORB x 3/4" hose barb in the suction port of the pump and install a 3/4" ID suction hose. Secure the suction hose in place using hose clamps. Install a 1 1/16 ORB x 3/8 NPT adapter and a 3/8 NPT 90° swivel adapter in the 'IN' port of the control valve and a 7/8 ORB x 3/8 NPT adapter in the pressure port of the pump. Connect a 72" long 3/8" hose between the pump and the valve.

Install 3/4 ORB male x 3/4 JIC male 90° adapters in the work ports of the control valve and 9/16 ORB male x 3/4 JIC male straight adapters in the ports on the cylinder. Connect the shorter 3/8" hose with 3/4 JIC fittings from the 'B' port on the control valve to the base end port on the cylinder; connect the longer 3/8" hose with 3/4 JIC fittings from the 'A' port to the rod end port. This will raise the hoist when the control lever is pulled back and lower it when pushed forward.



**NOTE:** The 'A' port is the 'power-down' port and has a pressure of only 500-1000 PSI; the 'B' port has full system pressure.

## INSTALL HOSES - D-10 (DAVID), E-15 (ERNIE) & F-18 (FLOYD)

Study Fig. 10 very carefully before connecting the hoses. Install a 90° street elbow and a hose barb in the suction port on the bottom of the reservoir. Install a hose barb in the suction port of the pump and install the suction hose. Secure the suction hose in place using hose clamps.

Install a 90° swivel adapter in the 'IN' port of the control valve and install a reducing adapter in the pressure port of the pump. Install the 1/2" ID, 72" long hose (3500 psi minimum pressure rating) from the pump to the valve. Install 7/8 ORB male x 3/4 JIC male 90° adapters in the work ports of the control valve. Install 3/4 ORB male x 3/4 JIC male straight adapters in the ports on the cylinder.

Connect the shorter 3/8" hose with 3/4 JIC fittings from the base end port of the cylinder to the 'B' port on the control valve. Connect the longer 3/8" hose with 3/4 JIC fittings from the rod end port of the cylinder to the 'A' port on the control valve. This will raise the hoist when the control lever is pulled back and lower it when pushed forward.

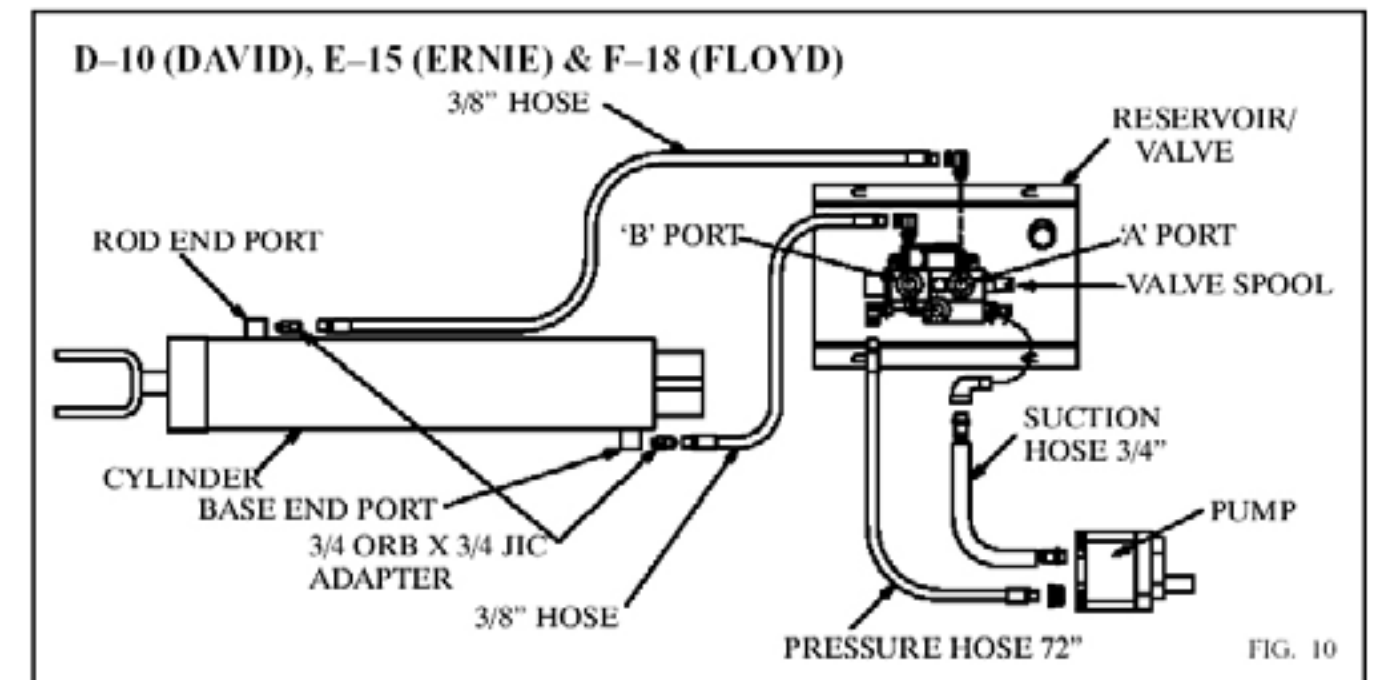

**NOTE:** The 'A' port is the 'power-down' port and has a pressure of only 500-1000 PSI; the 'B' port has full system pressure.

## ADD HYDRAULIC FLUID

Use an ISO 32 grade hydraulic fluid which contains corrosion and oxidation inhibitors and a foam depressant. This is approximately the equivalent of SAE 10W or lighter weight oil. Initially fill the reservoir with the quantities given below. **DO NOT OVERFILL THE RESERVOIR!**

**KEEP THE OIL CLEAN! USE CLEAN CONTAINERS, FUNNELS AND OTHER EQUIPMENT!**

HOIST MODEL	RESERVOIR SIZE	FLUID REQUIRED
B-5 (BERT)	15 QUARTS	10 QUARTS
C-8 (CHARLIE)	15 QUARTS	10 QUARTS
D-9 (DANIEL)	15 QUARTS	10 QUARTS
D-10 (DAVID)	6 GALLONS	4 GALLONS
D-15 (ERNIE)	6 GALLONS	4 GALLONS
F-18 (FLOYD)	8 GALLONS	5.5 GALLONS

NOTE: If the pump does not pump oil, pressurize the reservoir and engage the pump with the engine at slow idle. Once the pump is working, release the pressure and install the breather cap.

For the B-5 (Bert) model hoist, fully raise and lower the hoist several times to remove air from the cylinder and hoses. For C-8 (Charlie), D-9 (Daniel), D-10 (David), E-15 (Ernie), F-18 (Floyd) and H-25 (Henry) hoist models, fully raise the hoist and hold the hoist control in the 'RAISE' position for 20 to 30 seconds. This will remove the air that is inside the cylinder(s). Lower the hoist and check the fluid level in the reservoir; the reservoir should be 2/3 full with the body down.

With normal use and working conditions the hydraulic oil should be changed annually. The breather cap should be cleaned every time the hydraulic oil is changed. With heavy use or very dusty working conditions the hydraulic oil should be changed more often.

## ELECTRIC POWER UNIT MOUNTING - GENERAL

The electric power unit should be mounted close behind the cab, either inside or outside the truck frame. After determining where to mount the power unit, bolt one mounting angle to the power unit using the 3/8 x 1 hex head cap screws, tightening to 24 to 26 lb-ft. (See Fig. 11.) Clamp the mounting bracket to the truck frame. Clamp the second mounting angle to the truck frame so it supports the far end of the reservoir. Insert a rubber pad between the mounting angle and the reservoir; and secure it in place with a tie strap. Mark the truck frame for drilling using the pump mounting angles as guides.

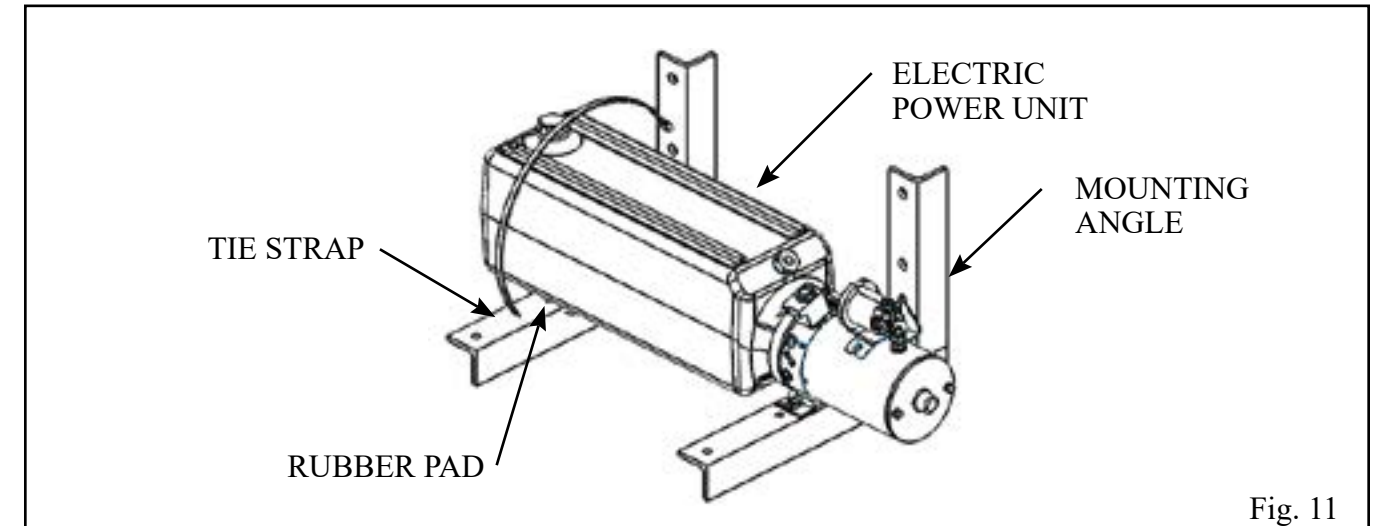

Fig. 11

**CAUTION: BE CAREFUL OF BRAKELINES, WIRING, ETC. INSIDE THE TRUCK FRAME WHEN DRILLING THE TRUCK FRAME.**

Drill 17/32" holes in the truck frame and bolt the reservoir/valve assembly in place using 1/2 x 2 cap screws and hex lock nuts, tightening to 90 to 100 lb-ft.

For rated performance, the voltage at the power unit must be a minimum of 12VDC. This should be measured between the large terminal of the start solenoid (where the battery cable is connected) and the power unit base. NOTE: Grounding of the power unit is just as important as the installation of the positive battery cable. It is easier to get a good ground by using a second battery cable.

Connect the large terminal on the motor start solenoid to the positive terminal on the battery with a #0 gauge battery cable. Connect the negative terminal on the battery to the grounding hole on the power unit with a #0 gauge battery cable. See Figure 12. Check the voltage between the large terminal on the start solenoid and the power unit base.



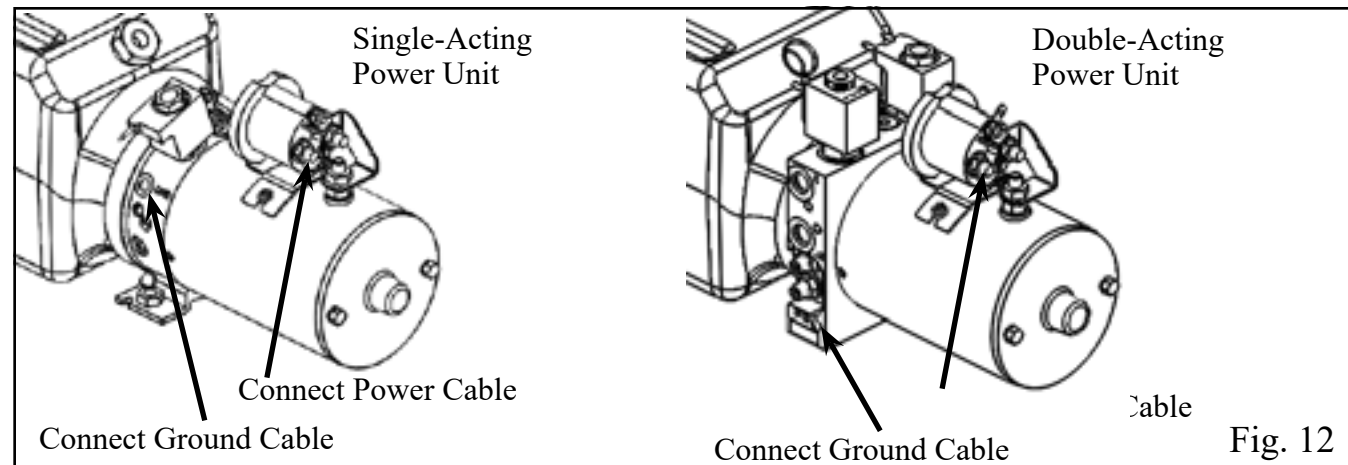

Locate the control in the cab and route the cable out of the cab through a hole in the back of the cab. Connect the control to the electric power unit using the 3- or 4-pin connector set.

After completing the wiring, install the motor start switch cover over the start switch and secure with a tie strap.

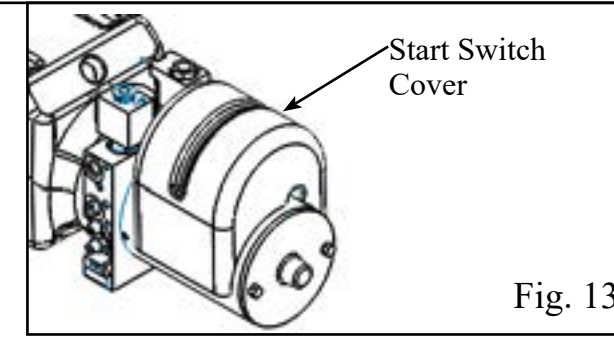

**INSTALLHOSES-SINGLE-ACTING**

Install a 9/16 ORB x 3/4-16 JIC straight adapter in the power port on the electric power unit, install a 3/4 JIC x 3/4 JIC 90° swivel adapter to this adapter and install a 1/4 NPT x 3/4-16 JIC male elbow in the port on the angled face of the reservoir.

For the B-5 (Bert), C-8 (Charlie) & D-9 (Daniel) models, install 9/16 ORB male x 3/4 JIC male adapters in both ports on the cylinder. For the D-10 (David), E-15 (Ernie) & F-18 (Floyd) models, install 3/4 ORB male x 3/4 JIC male adapters in both ports on the cylinder.

Connect the shorter 3/8" hose with 3/4 JIC fittings from the base end port of the cylinder to the power port on the electric power unit. Connect the longer 3/8" hose with 3/4 JIC fittings from the rod end port of the cylinder to the port on the reservoir. (See Fig. 13.)

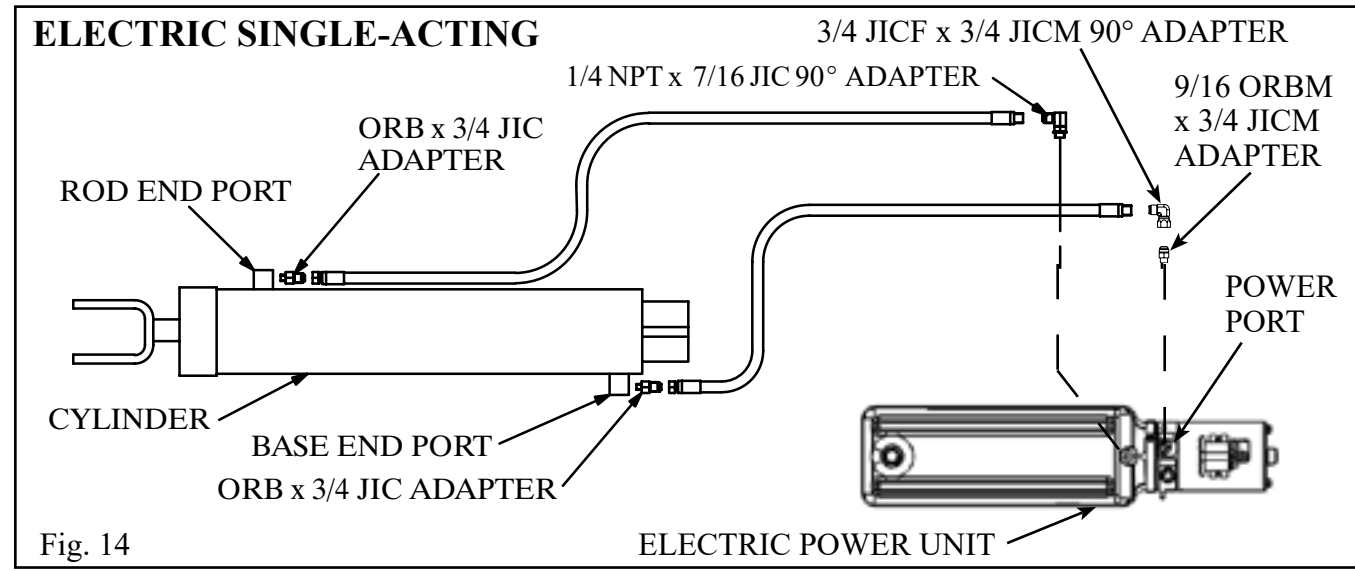

**INSTALLHOSES-DOUBLE-ACTING**

Install 9/16 ORB x 3/4 JIC straight adapters in both work ports on the electric pump. If needed, for good hose routing, install 3/4 JIC x 3/4 JIC 90° swivel adapters to both of these adapters.

For the B-5 (Bert), C-8 (Charlie) & D-9 (Daniel) models, install 9/16 ORB male x 3/4 JIC male straight adapters in both ports on the cylinder. For the D-10 (David), E-15 (Ernie) & F-18 (Floyd) models, install 3/4 ORB male x 3/4 JIC male straight adapters in both ports on the cylinder.

Connect the shorter 3/8" ID hose with 3/4 JIC fittings from the 'C1' port on the pump to the base end port on the cylinder. Connect the longer 3/8" ID hose with 3/4 JIC fittings from the 'C2' port to the rod end port. (See Fig. 14.)

NOTE: The 'C2' port is the power down port and has only 1000 PSI maximum pressure.

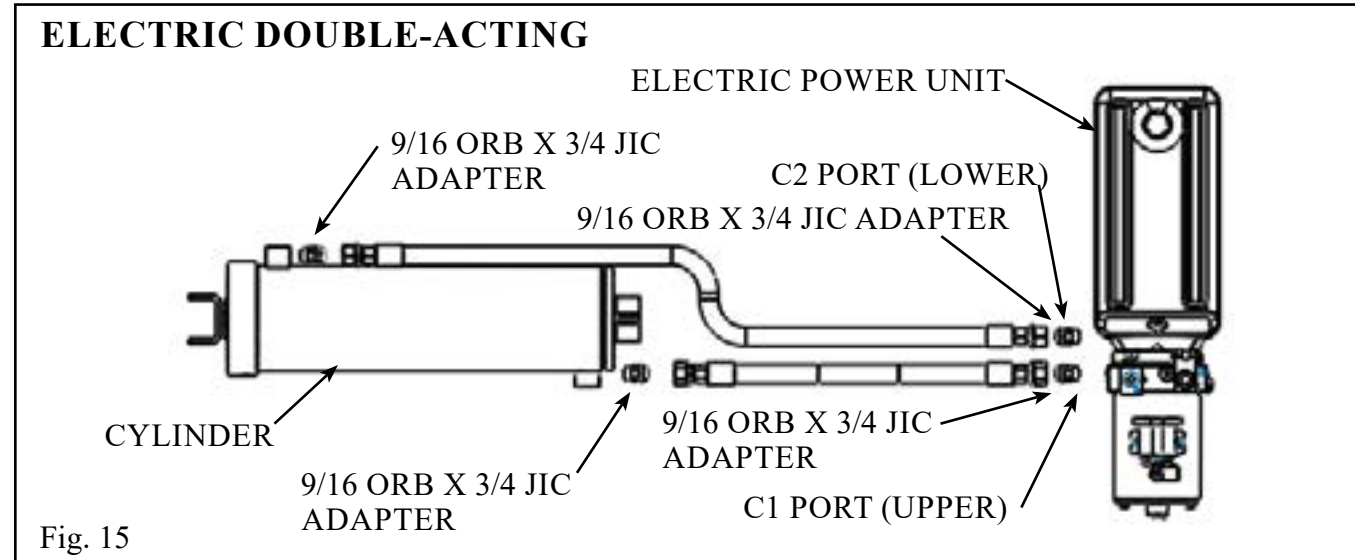

## ADD HYDRAULIC FLUID

Use an ISO 32 grade hydraulic fluid which contains corrosion and oxidation inhibitors and a foam depressant. This is approximately the equivalent of SAE 10W or lighter weight oil. Dexron automatic transmission fluid can be used in the electric power units. Initially fill the hydraulic reservoir using the following table. **DO NOT OVERFILL THE RESERVOIR!**

Function	Hoist Model	Reservoir Size	Fluid Required	Initial Fill
Single-Acting	B-5 (Bert)	10.5 Quarts	10 Quarts	10.5 Quarts
	C-8 (Charlie)	10.5 Quarts	10 Quarts	10.5 Quarts
	D-9 (Daniel)	10.5 Quarts	10 Quarts	10.5 Quarts
	D-10 (David)	10.5 Quarts	10 Quarts	10.5 Quarts
Double-Acting	B-5 (Bert)	7.5 Quarts	10.5 Quarts	7.5 Quarts
	C-8 (Charlie)	7.5 Quarts	12 Quarts	7.5 Quarts
	D-9 (Daniel)	7.5 Quarts	13 Quarts	7.5 Quarts
	D-10 (David)	7.5 Quarts	13.5 Quarts	7.5 Quarts
	D-15 (Ernie)	7.5 Quarts	16.5 Quarts	7.5 Quarts
	F-18 (Floyd)	7.5 Quarts	20 Quarts	7.5 Quarts

### **KEEP THE OIL CLEAN! USE CLEAN CONTAINERS, FUNNELS AND OTHER EQUIPMENT!**

For the B-5 (Bert) model hoist, fully raise and lower the hoist several times to remove air from the cylinder and hoses.

For C-8 (Charlie), D-9 (Daniel) and D-10 (David) hoist models with single-acting power units, fully raise the hoist and hold the 'UP' button for 20-30 seconds. This will remove the air that is inside the cylinder. Lower the hoist and check the fluid level in the reservoir; the fluid level should be within 1" of the top of the reservoir with the body down. Single-acting power units are not available for the E-15 (Ernie) and F-18 (Floyd) hoist models.

For C-8 (Charlie) and D-9 (Daniel) hoist models with double-acting power units, fully raise the hoist and hold the 'UP' button for 20-30 seconds. For D-10 (David), E-15 (Ernie) and F-18 (Floyd) hoist models with double-acting power units, raise the hoist until there is 2" of ATF in the reservoir. Add 2 quarts and raise the hoist until there is 2" of ATF in the reservoir. Repeat this until the hoist can be fully raised. Fully raise the hoist and hold the 'UP' button for 20-30 seconds. This will remove the air that is inside the cylinder. Lower the hoist and check the fluid level in the reservoir; the fluid level should be within 1" of the top of the reservoir with the body down.

With normal use and working conditions the automatic transmission fluid should be changed annually. The breather cap should be cleaned every time the fluid is changed. With heavy use or very dusty working conditions the fluid should be changed more often.

## MOUNTBODY

It is recommended that the body be painted before it is mounted on the truck. Place the body in position on the truck with three inches of clearance behind the cab. Use the rivet strips to fill the space between the longbeams and the truck frame. Use three on each side, one near the front of the body and two evenly spaced between the hoist mount and the rear hinge. Weld them to the longbeams. Align the body longbeams carefully with the truck frame. Securely weld the longbeams to the rear hinge brackets and to the upper hoist pivot pads.

On the inside of the longbeams, securely weld the longbeam fillers to the top of the upper hoist pivot pads and to the top flange of the longbeam channels as shown in Figure 15. For Crysteel's Grain Tipper, place the 9 inch square plate between the angle lift bracket and the inside of the longbeam as shown in Figure 16. Securely weld this plate to the longbeam and to the upper hoist pivot pad. Be sure to do this on both sides.

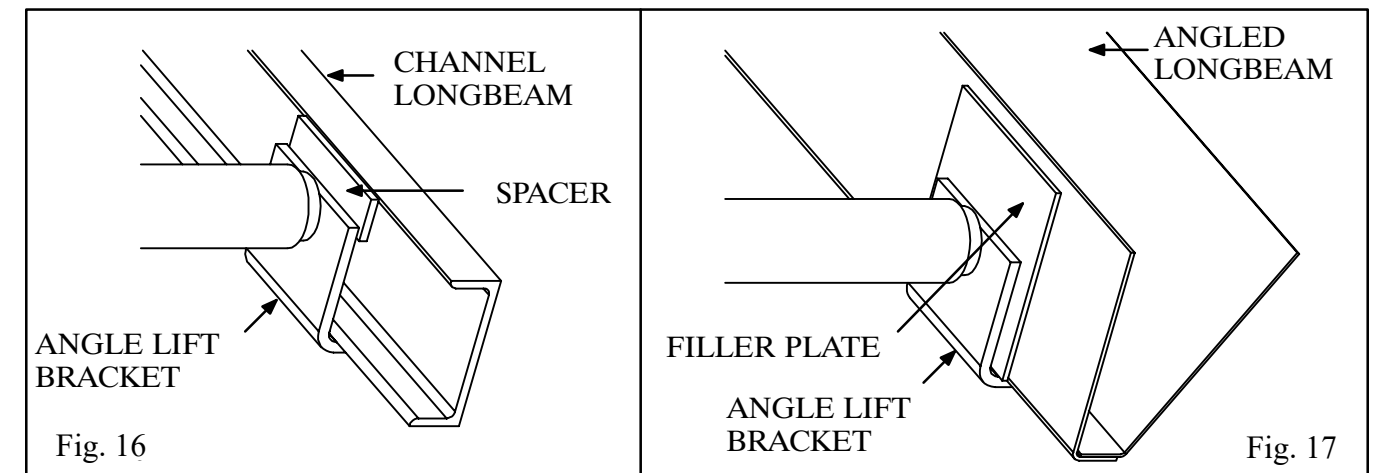

### **DO NOT WORK UNDER A RAISED BODY UNLESS THE BODY IS SECURELY BLOCKED OR PROPPED IN THE RAISED POSITION.**

See specifications on page 34 for minimum floor heights.

## INSTALL BODY GUIDE PLATES

Crysteel recommends that plates be installed on the inside of the body longbeams to work with the body guides built into the hoist frame to keep the body and truck frame aligned when the body is down. (See Fig. 17.)

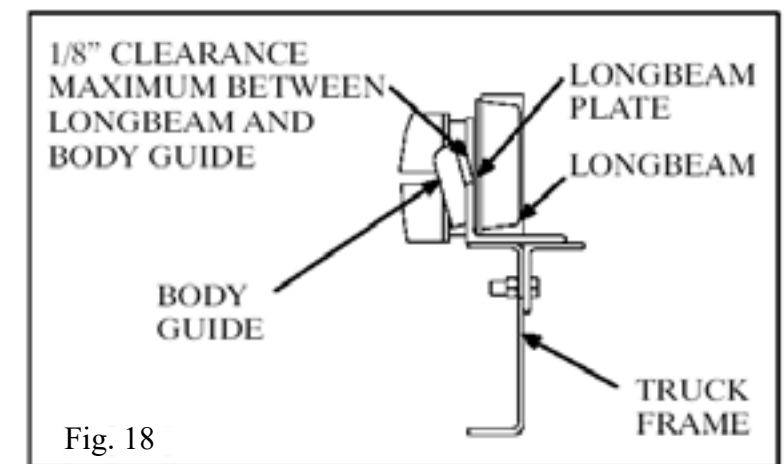

## INSTALL BODY PROP

The body prop is designed and intended to support an EMPTY truck body in the raised position. Use of the body prop permits service to be performed safely beneath a raised body. It is mounted on the outside of the truck frame on the drivers side.

1. Raise the body half way up and brace it securely before beginning installation.
2. Install the prop arm on the hoist mount / prop pivot with a 1/4 x 3 roll pin. Raise the body prop arm to the vertical, free standing position. Place the body prop bracket in the prop arm saddle. Lower the body so the bottom of the longbeam body prop bracket is between 1/2" and 1 1/2" up from the bottom of the body longbeam. For bodies with angled longbeams, keep the longbeam body prop bracket as low as possible. Securely weld the bracket to the longbeam.
3. To operate the body prop, raise the body to the desired height, shut off all power, raise the prop arm to a free standing position. Lower the body slowly until the body prop bracket contacts the prop arm saddle.
4. To place the body prop in the storage position, raise the body to clear the body prop saddle, lower the body prop to the storage position and lower the body.

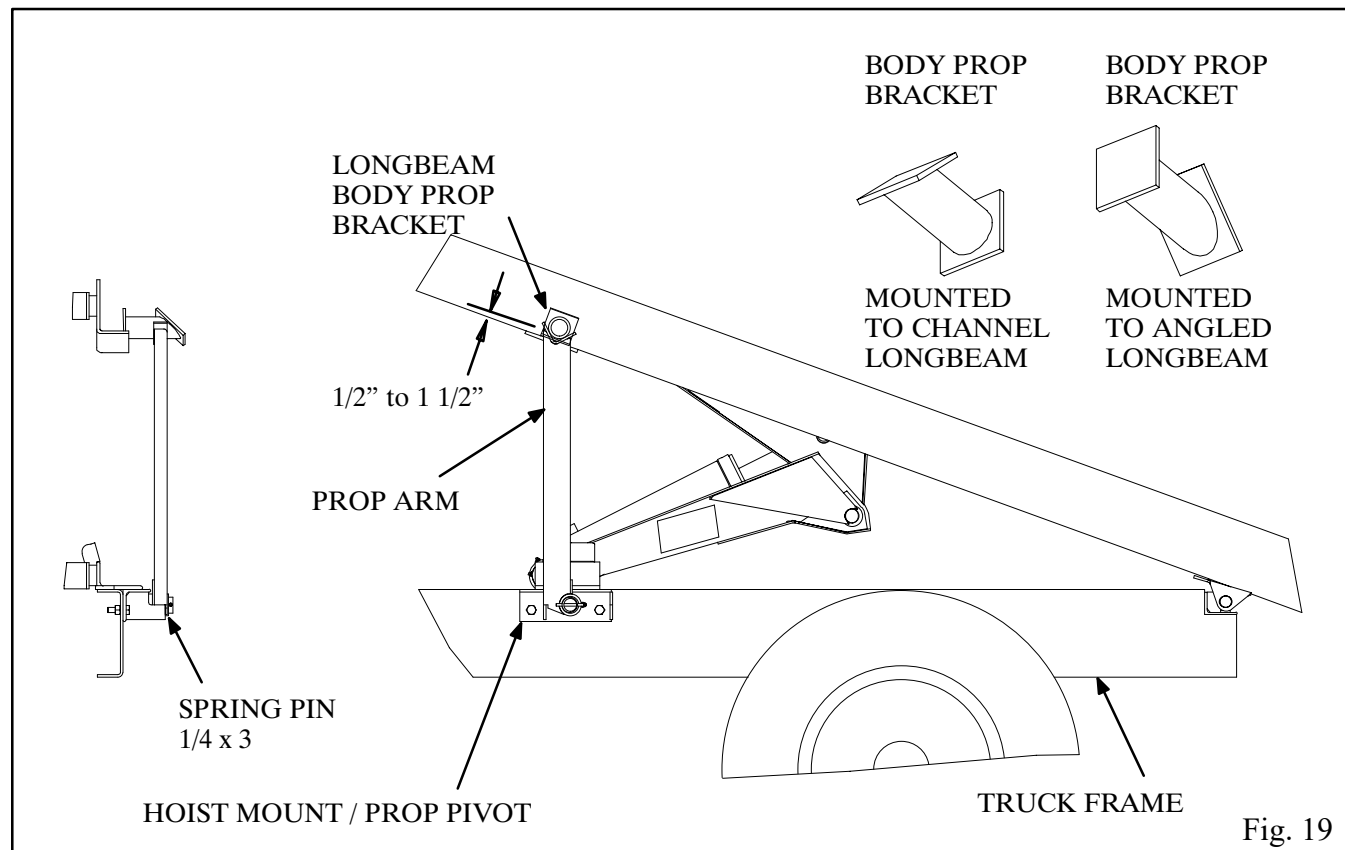

Fig. 19

An optional passenger's side prop kit is available.

5. When mounting the passenger's side prop, replace the hoist mounting angle with the hoist mount/prop pivot. Prop the body in the raised position using the driver's side prop. This will ensure that both props are supporting the empty body.

## INSTALL GREASE ZERKS AND LUBRICATE

Install grease zerks in the hoist frame. Lubricate all fittings at regular intervals, at least every 100 cycles or every two months. The grease fittings are located (See Fig. 19.) as follows:

- |    |                            |                    |
|----|----------------------------|--------------------|
| A. | Rear Hinge .....           | 2 fittings         |
| B. | Lower Cylinder Mount ..... | 2 fittings         |
| C. | Lower Crosstube .....      | 1 fitting per prop |
| D. | Upper Crosstube .....      | 2 fittings         |
| E. | Cylinder Crosshead .....   | 1 90° fitting      |
| F. | Center Hinge .....         | 1 fitting          |
| G. | Body Prop .....            | 1 90° fitting      |

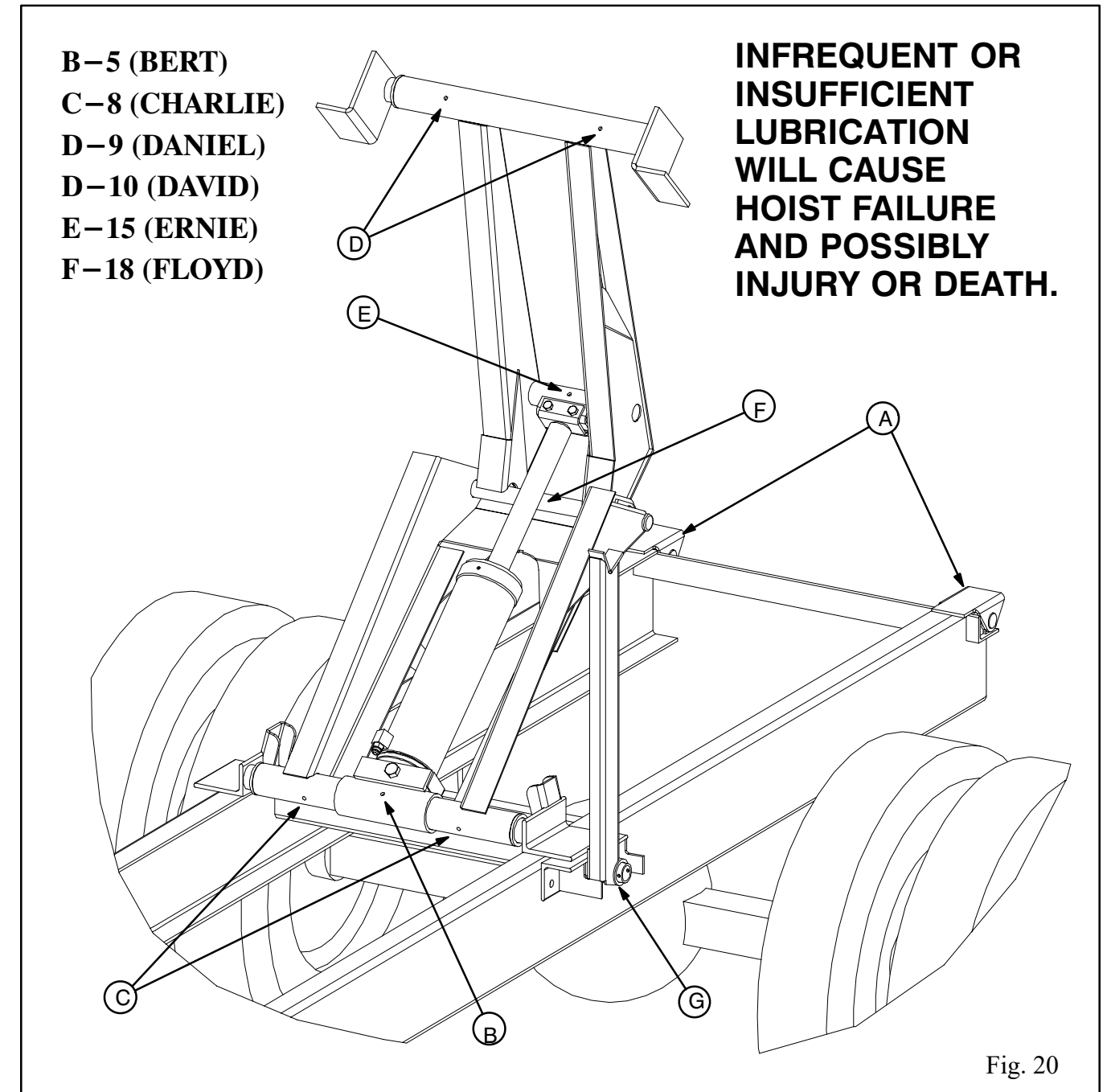
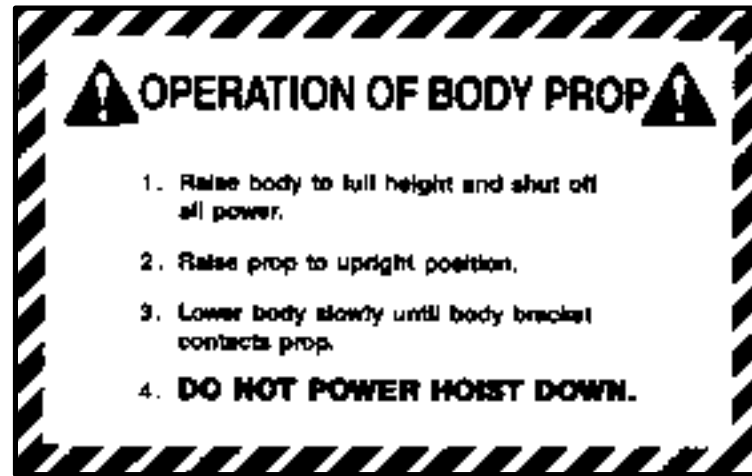

Fig. 20

**MOUNTDECALS**

Mount decals in the proper places as shown in Figure 20.



1642848 Mount on the body longbeam near the body prop

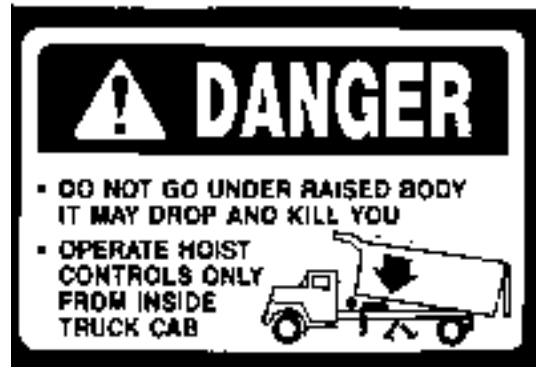

1643067 Mount on the outside of the body longbeams near the front of the body (one on each side).



1642844 Mount on the longbeam on the drivers side.



1643068 Mount in the cab in a prominent location



1642843 Mount in the cab in a prominent location'



1642846 Mount on the body prop arm.

Fig. 21

**HOIST PARTS B-5 (BERT), C-8 (CHARLIE), D-9 (DANIEL), D-10 (DAVID), E-15 (ERNIE) & F-18 (FLOYD)**

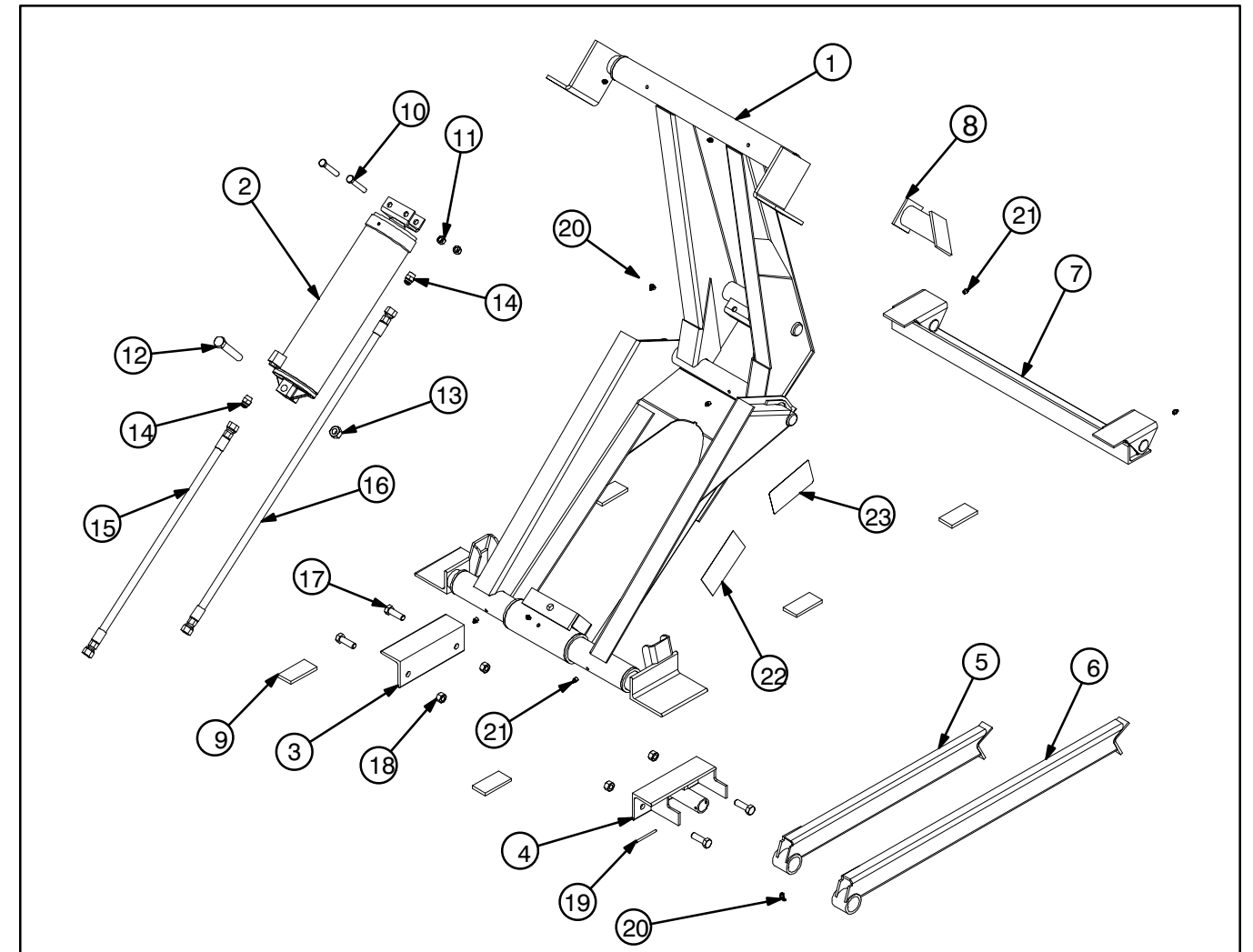

No.	Description	Model B-5 (Bert)	Model C-8 (Charlie)	Model D-9 (Daniel)	Model D-10 (David)	Model E-15 (Ernie)	Model F-18 (Floyd)	Qty
1.	Assy Frame	1624895	1624895	1624895	1624213	1624264	1624674	1
2.	Assy Cylinder	1621572	1621725	1622030	1624216	1624266	1624589	1
3.	Mounting Angle	1629458	1629458	1629458	1629458	1629458	1629458	1
4.	Assy Mount/Pivot - Driver's Side	1625146	1625146	1625146	1625146	1625146	1625146	1
	Assy Mount/Pivot - Passenger Side	1625147	1625147	1625147	1625147	1625147	1625147	1
5.	Assy Prop Arm 30" - Driver's Side	1625101	1625101	1625101	1625101	1625101		1
	Assy Prop Arm 30" - Passenger Side	1625102	1625102	1625102	1625102	1625102		1

No.	Description	Model B-5 (Bert)	Model C-8 (Charlie)	Model D-9 (Daniel)	Model D-10 (David)	Model E-15 (Ernie)	Model F-18 (Floyd)	Qty
6.	Assy Prop Arm 42" - Driver's Side						1625149	1
	Assy Prop Arm 42" - Passenger Side						1625150	1
7.	Assy Rear Hinge	1621645	1621645	1621645	1621587	1621587	1621587	1
8.	Assp Prop Bracket	1622175	1622175	1622175	1622175	1622175	1622175	1
9.	Spacer Longbeam	1629377	1629377	1629377	1629377	1629377	1629376	6
10.	Cap Screw, Hex Hd - 1/2-13 x 4 Gr 8	1642958	1642958	1642958	1642958	1642958	1642958	2
11.	Hex Lock Nut 1/2-13	1642984	1642984	1642984	1642984	1642984	1642984	2
12.	Cap Screw, Hex Hd - 3/4-10 x 5 1/2 Gr 8	1368341	1368341	1368341	1368341	1368341	1368341	1
13.	Hex Lock Nut 3/4-10	1642957	1642957	1642957	1642957	1642957	1642957	1
14.	Adapter 9/16 ORB x 3/4 JIC	1643375	1643375	1643375				2
	Adapter 3/4 ORB x 3/4 JIC				1643586	1643586	1643586	2
15.	Hose 3/4 JIC x 36"						1643797	1
	Hose 3/4 JIC x 42"				1643359	1643359		1
	Hose 3/4 JIC x 48"	1643360	1643360	1643360				1
16.	Hose 3/4 JIC x 60"	1643376	1643376	1643376	1643376	1643376		1
	Hose 3/4 JIC x 66"						1643505	1
17.	Cap Screw, Hex Hd - 5/8-11 x 2 Gr 8	1643313	1643313	1643313	1643313	1643313	1643313	4
18.	Hex Lock Nut 5/8-11	1643070	1643070	1643070	1643070	1643070	1643070	4
19.	Roll Pin 1/4 x 3	1642757	1642757	1642757	1642757	1642757	1642757	1
20.	Grease Zerk 1/8 NPT 90°	1642713	1642713	1642713	1642713	1642713	1642713	2
21.	Grease Zerk 1/8 NPT	1645187	1645187	1645187	1645187	1645187	1645187	8
22.	Decal LoBoy	1644452	1644452	1644452	1644452	1644452	1644452	1
23.	Decal Lubrication	1644617	1644617	1644617	1644617	1644617	1644617	1
24.	Decal Kit	1621809	1621809	1621809	1621809	1621809	1621809	1
25.	Body Prop Kit - Driver's Side	1625185	1625185	1625185	1625185	1625185	1625187	1
26.	Body Prop Kit - Passenger Side	1625186	1625186	1625186	1625186	1625186	1625188	1

## CYLINDERPARTS

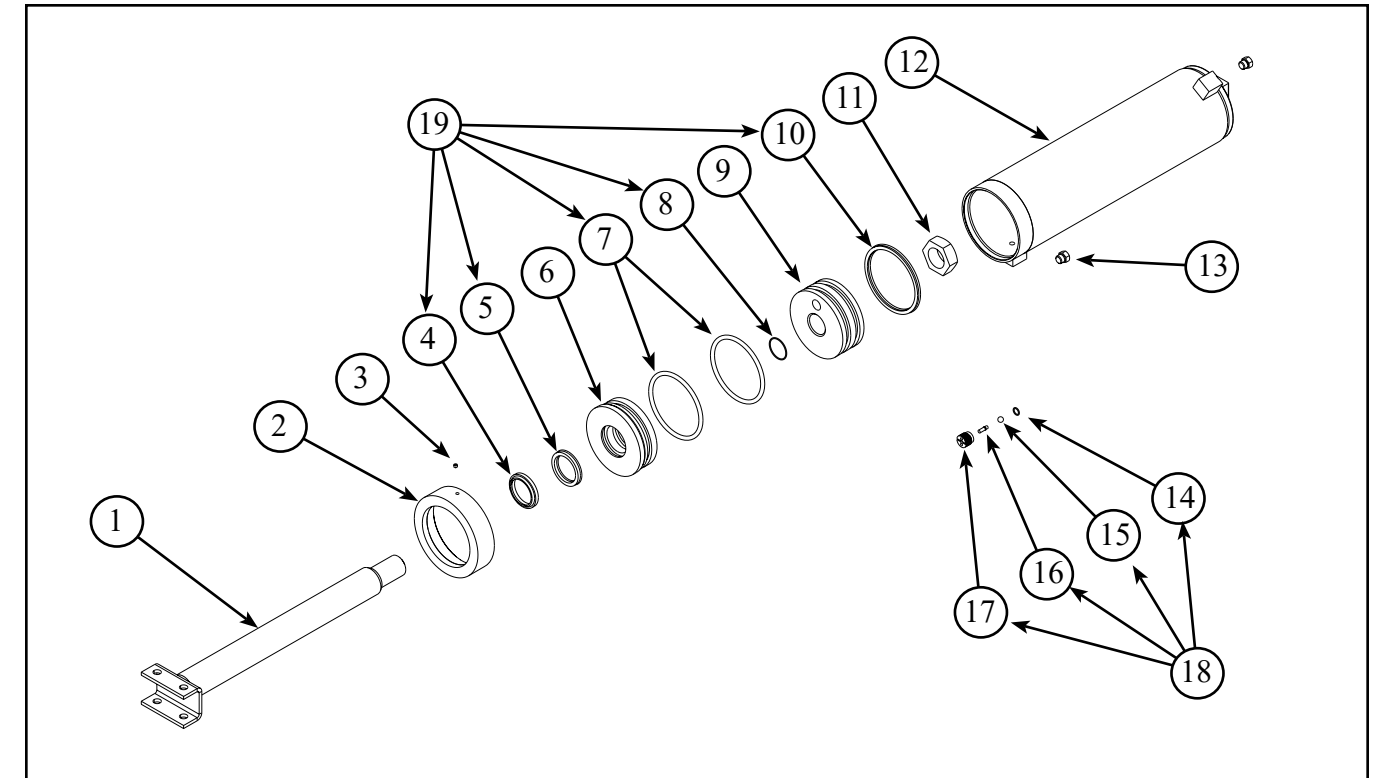

No.	Description	Model B-5 (Bert)	Model C-8 (Charlie)	Model D-9 (Daniel)	Model D-10 (David)	Model E-15 (Ernie)	Model F-18 (Floyd)	Qty
1.	Assy Shaft	1621574	1621727	1621727	1624218	1624218	1624592	1
2.	Cap Ring	1414735	1414736	1414737	1414736	1414738	1414738	1
3.	Set Screw, Nylon Tip 1/4"	1642724	1642724	1642724	1642724	1642724	1642724	1
4.	Wiper	1642942	1642878	1642878	1642878	1642878	1642879	1
5.	Shaft Seal	1642941	1642765	1642765	1642765	1642765	400907	1
6.	Cylinder Head	1634980	1637938	1634982	289667	1634983	1636110	1
7.	O-Ring	400263	1642766	400276	1642766	1642770	1642770	2
8.	O-Ring	1642940	1642767	1642767	1642767	1642767	1642767	1
9.	Cylinder Piston	1629848	1629601	1629802	1629601	1629604	1629604	1
10.	Piston Seal	1642773	1642764	1642780	1642764	1642769	1642769	1
11.	Hex Jam Nut 1 1/2-12		1642995	1642995	1642995	1642995	1642995	1
12.	Assy Cylinder Tube	1621573	1621726	1622031	1624217	1624267	1624591	1
13.	Plug ORB	1642793	1642793	1642793	1642805	1642805	1642805	1
14.	O-Ring 7/16		1642907	1642907	1642907	1642907	1642907	1
15.	Ball - 3/8		1642679	1642679	1642679	1642679	1642679	1
16.	Bypass Valve Pin		1642894	1642894	1642894	1642894	1642894	1
17.	Bypass Valve Body		1642893	1642893	1642893	1642893	1642893	1
18.	Bypass Valve Kit		1621569	1621569	1621569	1621569	1621569	1
19.	Seal Kit	1621639	1621640	1621641	1621640	1621642	1621642	1

**HYDRAULIC SYSTEM PARTS - BERT, CHARLIE, DANIEL**

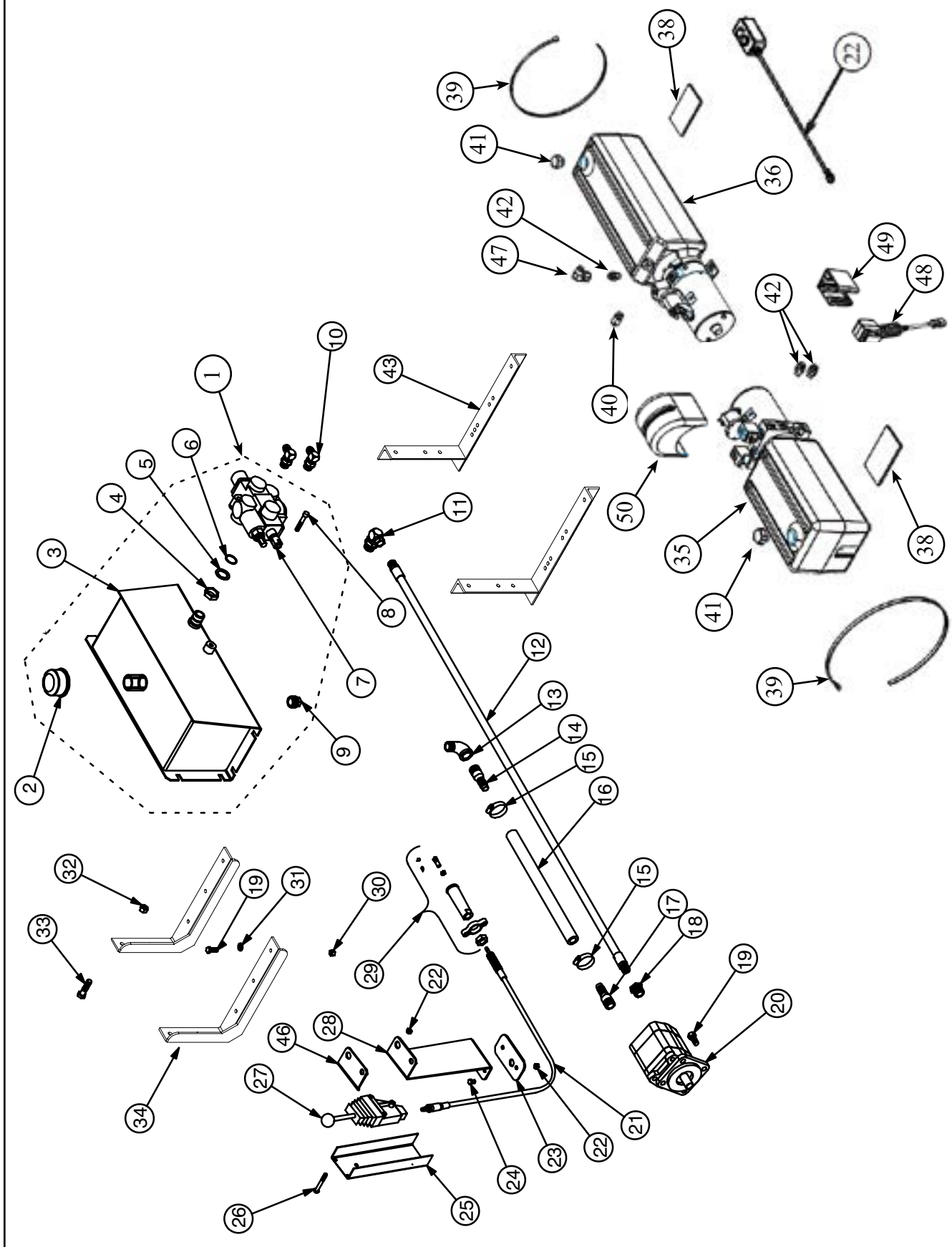

ITEM	DESCRIPTION	B-5 (Bert)	C-8 (Charlie)	D-9 (Daniel)	QTY
1.	Assy Reservoir/Valve 15 QT 3250 DA	1622192	1622192	1622192	1
2.	Breather Cap	1644723	1644723	1644723	1
3.	Assy Reservoir Weldment	1622166	1622166	1622166	1
4.	Hex Jam Nut 7/8-14	1643196	1643196	1643196	1
5.	Cone Washer 7/8	1643197	1643197	1643197	1
6.	O-Ring .755 ID x .094 CS	1643198	1643198	1643198	1
7.	Control Valve 12 GPM 3250 DA	1643398	1643398	1643398	1
8.	Cap Screw, Hex Hd 1/4-20 x 1 3/4 Gr 5	1643058	1643058	1643058	1
9.	Pipe Plug 3/4" Magnetic	1642794	1642794	1642794	1
10.	Adapter 3/4 ORM x 3/4 JICM 90°	1643357	1643357	1643357	2
11.	Adapter 7/8 ORM x 3/8 NPTF 90°	1642954	1642954	1642954	1
12.	Hose 3/8 NPT x 72 RM/RM 4000	1643014	1643014	1643014	1
13.	Pipe Street Elbow 3/4 90°	1643226	1643226	1643226	1
14.	Hose Barb 3/4 NPT x 3/4	1643017	1643017	1643017	1
15.	Hose Clamp #24	1643011	1643011	1643011	1
16.	Suction Hose 3/4" ID x 72"	1643805	1643805	1643805	1
17.	Hose Barb 1 1/16 ORBM x 3/4	1643228	1643228	1643228	1
18.	Adapter 7/8 ORM x 3/8 NPTF	1642813	1642813	1642813	1
19.	Cap Screw, Hex Hd 3/8-16 x 1 Gr 5	1642714	1642714	1642714	8
20.	Gear Pump 4 GPM - 9 Tooth	1644648	1644648	1644648	1
	Gear Pump 4 GPM -11 Tooth	1644649	1644649	1644649	1
21.	Cable, Valve Control - 96"	1643210	1643210	1643210	1
	Cable, Valve Control - 72"	1643209	1643209	1643209	1
	Cable, Valve Control - 84"	1643332	1643332	1643332	1
	Cable, Valve Control - 120"	1643211	1643211	1643211	2
	Cable, Valve Control - 144"	1643212	1643212	1643212	1
	Cable, Valve Control - 180"	1643213	1643213	1643213	1
	Cable, Valve Control - 240"	1643214	1643214	1643214	1
22.	Hex Lock Nut 5/16-18	1642962	1642962	1642962	5
23.	Clamp Plate - Pedestal	1631026	1631026	1631026	1
24.	Cap Screw, Hex Hd 5/16-18 x 1/2 Gr 2	1643329	1643329	1643329	2
25.	Channel Pedestal	1630851	1630851	1630851	1
26.	Machine Screw 5/16-18 x 2 1/2 Rd Hd	1643233	1643233	1643233	3
27.	Remote Valve Control w/ Center Detent	1643208	1643208	1643208	1
28.	Pedestal	1630850	1630850	1630850	1
29.	Valve Connection Kit - Prince 4100	1643467	1643467	1643467	1
30.	Hex Lock Nut 3/8-16	1643177	1643177	1643177	4
31.	Flat Washer 3/8	1642732	1642732	1642732	4
32.	Hex Lock Nut 1/2-13	1642984	1642984	1642984	4
33.	Cap Screw, Hex Hd 1/2-13 x 2 Gr 8	1642701	1642701	1642701	4

ITEM	DESCRIPTION	B-5 (Bert)	C-8 (Charlie)	D-9 (Daniel)	QTY
34.	Assy Reservoir/Valve Mount	1622065	1622065	1622065	2
35.	Electric Power Unit - DA	2219241	2219241	2219241	1
36.	Electric Power Unit - SA	1200094	1200094	1200094	1
37.	Push-Button Control - SA 78"	1200093	1200093	1200093	1
38.	Rubber Pad 1/4 x 3 x 5	1643881	1643881	1643881	1
39.	Cable Tie - 33"	1643817	1643817	1643817	1
40.	Adapter 3/4 JICM x 1/4 NPTM 90°	1643374	1643374	1643374	1
41.	Breather Cap - Splash Resistant	1644498	1644498	1644498	1
42.	Adapter 9/16 ORBM x 3/4 JICM	1643375	1643375	1643375	1
43.	Assy Pump Mounting Angle	1621438	1621438	1621438	2
44.	Adapter 3/4 JICM x 3/4 JICM 90°	1643545	1643545	1643545	2
45.	Adapter 9/16 ORBM x 3/4 JICM 90°	1643544	1643544	1643544	2
46.	Decal - Hoist Control	1643216	1643216	1643216	1
47.	Adapter 3/4 JICM x 3/4 JICM 90°	1643545	1643545	1643545	1
48.	Control Station W/Cord, 4 Wire DA Pistol	2296414	2296414	2296414	1
49.	Keeper, Pistol Grip	2296415	2296415	2296415	1
50.	Cover Solenoid Service	1644330	1644330	1644330	1

**NOTES**

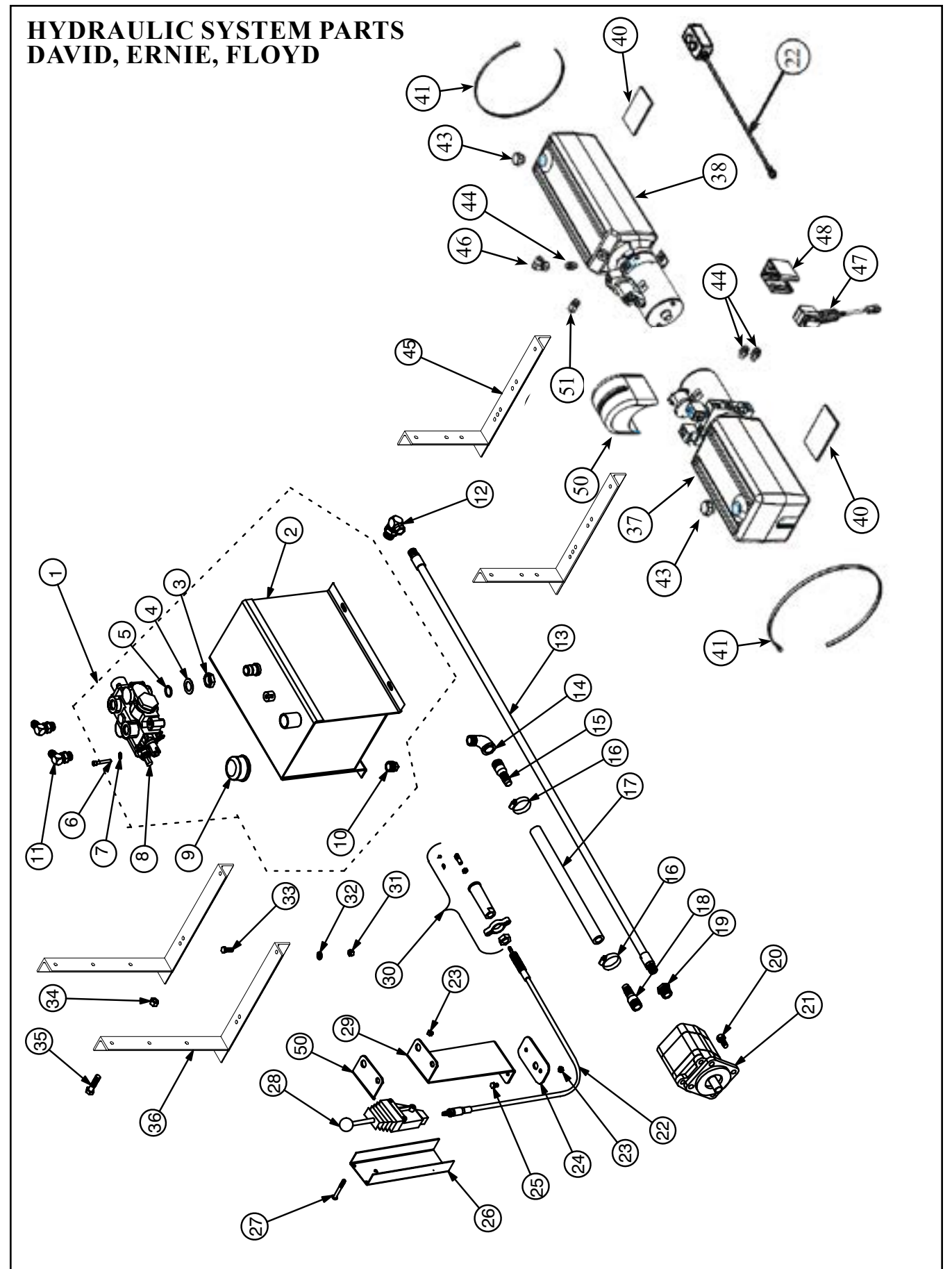

ITEM	DESCRIPTION	D-10 (David)	E-15 (Ernie)	F-18 (Floyd)	QTY
1.	Assy Reservoir/Valve (Carton) 3250 DA	1621943	1621943	1621945	1
2.	Assy Reservoir Weldment	1621925	1621925	1621921	1
3.	Hex Jam Nut 1 1/16-12	1643194	1643194	1643194	1
4.	Cone Washer 1 1/16	1643195	1643195	1643195	1
5.	O-Ring .924 ID x .116 CS	1642922	1642922	1642922	1
6.	Cap Screw, Soc Hd 5/16-18 x 2	1643205	1643205	1643205	1
7.	Lock Washer 5/16	1642733	1642733	1642733	1
8.	Control Valve 3250 DA	1643185	1643185	1643185	1
9.	Breather Cap	1644723	1644723	1644723	1
10.	Pipe Plug 3/4" Magnetic	1642794	1642794	1642794	1
11.	Adapter 7/8 ORM x 3/4 JICM 90°	1643356	1643356	1643356	2
12.	Adapter 1 1/16 ORM x 1/2 NPTF 90°	1642969	1642969	1642969	1
13.	Hose 1/2 NPT x 72 RM/RM 3500 PSI	1643015	1643015	1643015	1
14.	Pipe Street Elbow 3/4 90°	1643226	1643226		1
	Pipe Street Elbow 1 1/4 90°			1642975	1
15.	Hose Barb 3/4 NPT x 3/4	1643017	1643017		1
	Hose Barb 1 1/4 NPT x 1 1/4			1643018	1
16.	Hose Clamp #24	1643011	1643011		2
	Hose Clamp 1 3/4" T-Bolt			1643241	2
17.	Suction Hose 3/4" ID x 72"	1643805	1643805		1
	Suction Hose 1 1/4" ID x 72"			1643806	1
18.	Hose Barb 1 1/16 ORBM x 3/4	1643228	1643228		1
	Hose Barb 1 5/16 ORBM x 1 1/4			1643019	1
19.	Adapter 1 1/16 ORBM x 1/2 NPTF	1283139	1283139		1
	Adapter 1 5/16 ORBM x 1/2 NPTF			1630083	1
20.	Cap Screw, Hex Hd 1/2-13 x 1 1/4 Gr 8	1642726	1642726	1642726	4
21.	Gear Pump 6 GPM - P20	1644773	1644773		1
	Gear Pump 10 GPM - P20			1644774	1
22.	Cable, Valve Control - 96"	1643210	1643210	1643210	1
	Cable, Valve Control - 72"	1643209	1643209	1643209	1
	Cable, Valve Control - 84"	1643332	1643332	1643332	1
	Cable, Valve Control - 120"	1643211	1643211	1643211	1
	Cable, Valve Control - 144"	1643212	1643212	1643212	1
	Cable, Valve Control - 180"	1643213	1643213	1643213	1
	Cable, Valve Control - 240"	1643214	1643214	1643214	1
23.	Hex Lock Nut 5/16-18	1642962	1642962	1642962	5
24.	Clamp Plate - Pedestal	1631026	1631026	1631026	1
25.	Cap Screw, Hex Hd 5/16-18 x 1/2 Gr 2	1643329	1643329	1643329	2
26.	Channel Pedestal, Tall	1630873	1630873	1630873	1
27.	Machine Screw 5/16-18 x 2 1/2 Rd Hd	1643233	1643233	1643233	3

ITEM	DESCRIPTION	D-10 (David)	E-15 (Ernie)	F-18 (Floyd)	QTY
28.	Remote Valve Control w/ Center Detent	1643208	1643208	1643208	1
29.	Pedestal Bracket, Tall	1630872	1630872	1630872	1
30.	Valve Connection Kit - Prince 5100	1643215	1643215	1643215	1
31.	Hex Lock Nut 3/8-16	1643177	1643177	1643177	4
32.	Flat Washer 3/8	1642732	1642732	1642732	4
33.	Cap Screw, Hex Hd 3/8-16 x 1 Gr 5	1642714	1642714	1642714	4
34.	Hex Lock Nut 1/2-13	1642984	1642984	1642984	4
35.	Cap Screw, Hex Hd 1/2-13 x 2 Gr 8	1642701	1642701	1642701	4
36.	Reservoir Mounting Angle	1621472	1621472	1621472	2
37.	Monarch Pump, DA 3250 PSI	1200097	1200097	1200097	1
38.	Monarch Pump, SA 3250 PSI 540 CI	1200094	N/A	N/A	1
39.	Push-Button Control - SA 78"	1200093	1200093	1200093	1
40.	Rubber Pad 1/4 x 3 x 5	1643881	1643881	1643881	1
41.	Cable Tie - 33"	1643817	1643817	1643817	1
42.	Adapter 3/4 JICM x 1/4 NPTM 90°	1643374	1643374	1643374	1
43.	Breather Cap - Splash Resistant	1644498	1644498	1644498	1
44.	Adapter 9/16 ORBM x 3/4 JICM	1643375	1643375	1643375	1
45.	Pump Mounting Angle	1621438	1621438	1621438	2
46.	Adapter 3/4 JICM x 3/4 JICM 90°	1643545	1643545	1643545	2
47.	Control Station W/Cord, 4 Wire DA Pistol	2296414	2296414	2296414	1
48.	Keeper, Pistol Grip	2296415	2296415	2296415	1
49.	Cover Solenoid Service	1644330	1644330	1644330	1
50.	Decal - Hoist Control	1643216	1643216	1643216	1



## SPECIFICATIONS

## NOTES

Hoist Model	Cylinder Bore	Cylinder Stroke	Cylinder Shaft	Operating Pressure	Minimum Floor Height
B-5 (BERT)	4.000"	15.25"	1.500"	3250 PSI	7"
C-8 (CHARLIE)	5.000"	15.25"	2.000"	3250 PSI	7"
D-9 (DANIEL)	5.500"	15.25"	2.000"	3250 PSI	7 1/2"
D-10 (DAVID)	5.000"	20.69"	2.000"	3250 PSI	7"
D-15 (ERNIE)	6.000"	20.69"	2.000"	3250 PSI	8"
F-18 (FLOYD)	6.000"	29.44"	2.250"	3250 PSI	9"

### CAPACITY FORMULA

The capacity of the LoBoy truck hoists can be calculated using the following steps.

1. Measure the distance, in inches, from the center of the rear hinge to the center of the body. Call this "A".
2. Measure the distance, in inches from the center of the rear hinge to the forward crosstube on the hoist. Call this "D". (See Figures 2, 3 & 4 for "D" dimensions for the various models.)
3. For Model B-5 (BERT), multiply "D" by 3.87.  
 For Model C-8 (CHARLIE), multiply "D" by 6.05.  
 For Model D-9 (DANIEL), multiply "D" by 7.32.  
 For Model D-10 (DAVID), multiply "D" by 6.16.  
 For Model E-15 (ERNIE), multiply "D" by 8.87.  
 For Model F-18 (FLOYD), multiply "D" by 8.75.
4. Divide the result of Step 3 by "A". This is the capacity in tons for an evenly distributed load (over the whole length of the body) and includes the weight of the body.

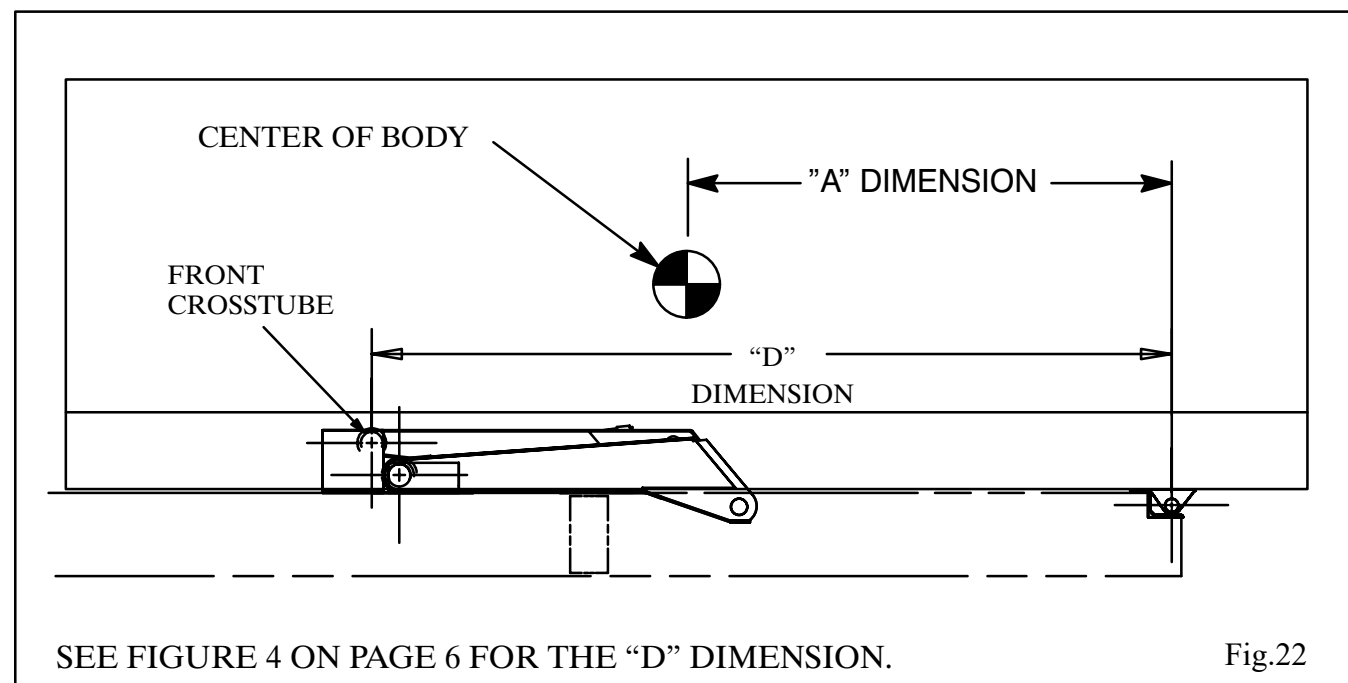

---

---

**CRYSTEEL MANUFACTURING'S  
5 YEAR CUSTOMER SATISFACTION PLEDGE  
& WARRANTY**

Crysteel offers the most comprehensive warranty in the truck equipment industry. Crysteel warrants each product against defects in material and workmanship for 60 months from the in-service date.

For the full Customer Satisfaction Pledge and Warranty information, please visit our website.

<http://www.crysteel.com>



**CRYSTEEL MANUFACTURING, INC.**

---

---