

CRYSTEEL'S LO-BOY LB520 TRUCK HOIST

OWNERS
MANUAL

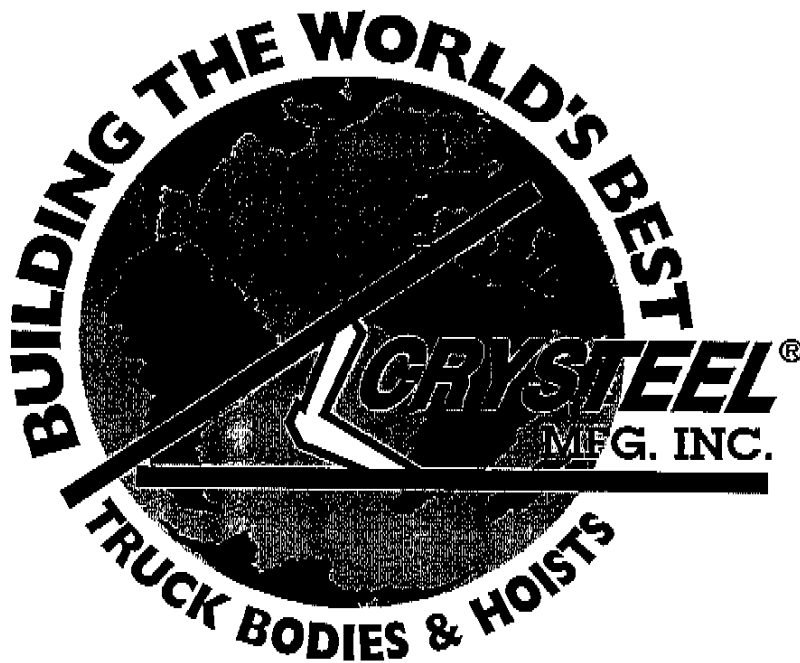

P.O. Box 178
52182 Ember Road
Lake Crystal, MN 56055

www.crysteel.com
crysteel@crysteel.com
(507) 726-2728 (800) 533-0494

1902 Route 57 South
Fulton, NY 13069

DATE PURCHASED

BODY SERIAL NUMBER

HOIST SERIAL NUMBER

CYLINDER SERIAL NUMBER

DEALER

ADDRESS

PHONE

FOREWORD

Crysteel's LB520 Hoist has been designed and intended for use on single-axle trucks with cab-to-axle dimensions of 72 to 132 inches and body lengths of 9 to 16 feet.

This manual contains information necessary for the proper installation and operation of Crysteel's Model LB520 Hoist. Study it carefully before attempting to mount or use the hoist. With proper installation and maintenance, the Crysteel Model LB520 Hoist will give many years of trouble-free service.

When ordering parts, be sure to give serial number of hoist, pump, and cylinder. The serial number of the pump is found on the plate on the pump. The serial number of the cylinder is stamped on the barrel of the cylinder near the base. For future reference, copy these numbers NOW in the space provided above. Order parts by number and description as given in the parts listing in this manual.

DANGER

- **DO NOT GO UNDER RAISED BODY
IT MAY DROP AND KILL YOU**
- **OPERATE HOIST
CONTROLS ONLY
FROM INSIDE
TRUCK CAB**



OPERATION AND USE

1. Engage PTO from cab and adjust engine speed to fast idle.
2. The hoist should raise when the hoist control lever is pulled back, hold when the lever is in the center detent, and lower when the lever is pushed forward.
3. To raise the hoist, pull the control lever back. To hold the body in a raised position, place the control lever in its center detent position. To lower the hoist, push the control lever forward.
4. ALWAYS return the hoist control lever to its center detent position after each use.
5. DO NOT LEAVE THE PTO IN GEAR WHILE TRANSPORTING. THIS CAN CAUSE SEVERE DAMAGE TO THE PTO OR HYDRAULIC PUMP/VALVE.
6. The hydraulic system should be drained, flushed and refilled with proper hydraulic fluid at regular intervals. CAUTION: NEVER use hydraulic BRAKE FLUID in the hydraulic system.

SOME DO'S AND DON'TS FOR SAFE AND LONG SERVICE

1. Use the proper hydraulic fluid. KEEP IT CLEAN. Remember to change it regularly.
2. Lubricate all grease fittings at regular intervals.
3. ALWAYS carefully block up the body, using the body prop, before working under it.
4. Do not "race" the engine when unloading.
5. Do not load the hoist beyond its capacity.
6. DO NOT tamper with the hydraulic relief valve. This will void the warranty. It can cause severe damage to the hoist and cylinder.
7. Never leave the PTO in gear while transporting. It could ruin the hydraulic pump, the PTO or the transmission.
8. Check all bolts and fittings regularly. Keep them tight.

TABLE OF CONTENTS

Purchase Record	1
Foreword	1
Operation and Use	2
Some Do's and Don't's	2
Table of Contents	3
Locate Hoist/Subframe Assembly	4
Locate Body/Hoist Assembly on Truck	4
Locate Mounting Plates	5
Drill Truck Frame	5
Weld Rear Hinge and Subframe	5
Hydraulic Pumps	6
Mount Gear Pump	6
Mount Reservoir/Valve Assembly	6
Install Remote Valve Control	7
Install 4 GPM Pump Hoses	8
Install 6 GPM Pump Hoses	8
Install Cylinder Hoses – Gear Pump Systems	8
Electric Pump Mounting – General	9
Install Cylinder Hoses – Single-Acting Electric Pump	10
Install Cylinder Hoses – Double-Acting Electric Pump	10
Add Hydraulic Oil	10
Power Hoist Down	11
Install Crysteel Tipper Body on Truck	11
Install Body on Truck	11
Install Body Prop Bracket on Body Longbeam	12
Install Body Guides	12
Install Grease Zerks and Lubricate	13
Install Decals	13
Parts Lists and Diagrams	15–20
Specifications	21
Warranty	Back Page

INSTALLATION INSTRUCTIONS

LOCATE HOIST/SUBFRAME ASSEMBLY

Place the hoist-subframe assembly on the truck frame so the back edge of the rear hinge is 2 inches or more behind the back side of the spring shackle. This will place the rear hinge pivot 30 to 36 inches behind the center of the rear axle. Mark the rear of the truck frame and cut off, as shown in Fig. 1.

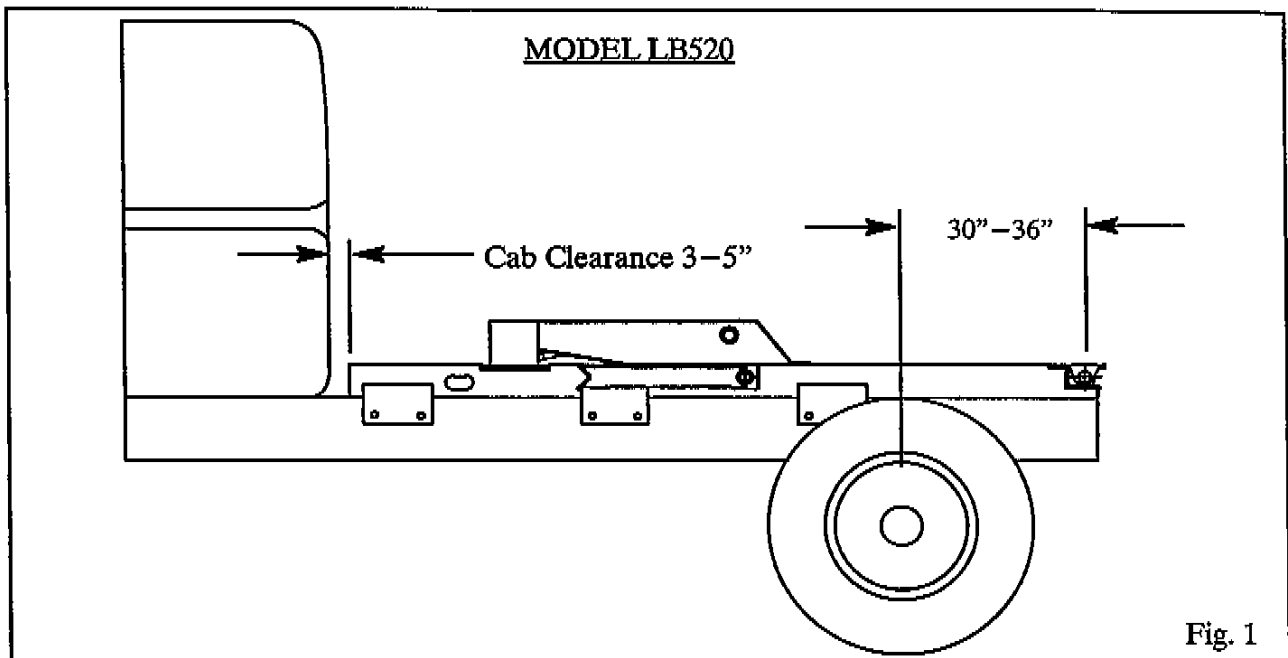

Fig. 1

NOTE: If the truck frame has rivets in the top flange, add spacers between the truck frame and subframe, or counter sink the rivet heads into the subframe by drilling holes in the subframe. Do not remove the rivet heads!

CAUTION: BE CAREFUL OF BRAKELINES, WIRING, ETC. INSIDE THE TRUCK FRAME WHEN DRILLING THE TRUCK FRAME.

LOCATE BODY/HOIST ASSEMBLY ON TRUCK

Use the following installation procedures when the body and hoist have been assembled at the factory. Place the body and hoist assembly on the truck frame so the back edge of the rear hinge is 2 inches or more behind the back side of the spring shackle. This should give 3 to 5 inches of cab clearance. Relocate the body and hoist, if necessary. The center of the rear hinge should never be more than 36 inches behind the center of the rear axle on single-axle trucks. The truck frame will need to be cut off even with the back end of the subframe rails, as shown in Fig. 3.

Block up the back end of the body/hoist assembly and cut the truck frame as marked.

NOTE: If the truck frame has rivets in the top flange, add spacers between the truck frame and subframe, or counter sink the rivet heads into the subframe by drilling holes in the subframe. Do not remove the rivet heads!

LOCATE MOUNTING PLATES

There are six mounting plates, three for each side – one at the front of the subframe, one at the hoist mount and one between the hoist mount and the rear hinge. Clamp the mounting plates to the truck frame and to the subframe as shown in Figures 1 and 2. If desired, locate the plates to use existing holes in the frame. Mark the mounting plates for drilling. Repeat this for the other side.

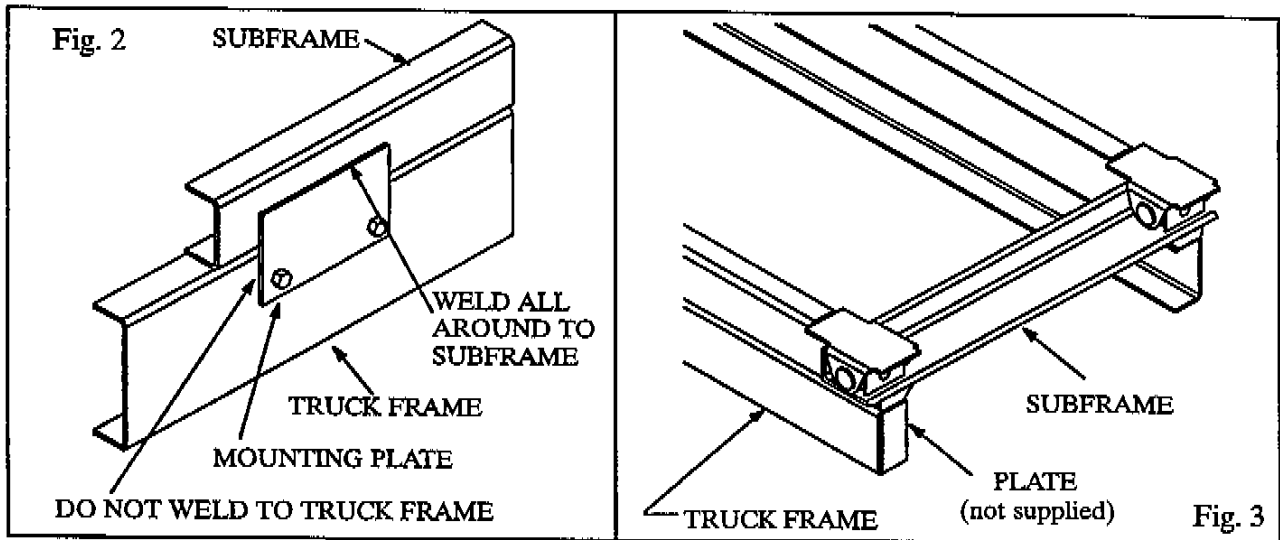

CAUTION: BE CAREFUL OF BRAKELINES, WIRING, ETC. INSIDE THE TRUCK FRAME WHEN DRILLING THE TRUCK FRAME.

DRILL TRUCK FRAME

Drill 21/32" holes in the mounting plates and the truck frame. Bolt the mounting plates in place using 5/8 x 2 cap screws (grade 8) and hex lock nuts, tightening to 180–190 lb–ft.

WELD REAR HINGE AND SUBFRAME

Make sure the body/hoist assembly or hoist/subframe assembly is correctly located, centered on and square with the truck frame. Securely weld the mounting plates to the subframe. Add a plate (not supplied) to the end of the truck frame rail. (See Fig. 3.) Securely weld the plates to the end of the truck frame rails and to the back end of the subframe. Do this on both sides.

HYDRAULIC PUMPS

Crysteel offers four different hydraulic systems for use with the Model LB520 Hoist. Mounting instructions can be found on the page shown:

Standard 4 GPM Gear Pump with Remote Reservoir/Valve	Page 5
Optional 6 GPM Gear Pump with Remote Reservoir/Valve	Page 5
Electric Pump—Single Acting	Page 8 & 9
Electric Pump—Double Acting	Page 8 & 9

MOUNT GEAR PUMP

The standard 4 GPM gear pump has an SAE 'A' mounting configuration, a 9 tooth splined shaft and a two-bolt mounting flange, and is assembled for counterclockwise rotation. *NOTE:* This pump will mount directly to Chelsea's output type 'XE' or Muncie's output type 'R'. Crysteel Manufacturing recommends a PTO ratio of 100–120%. This assures a minimum pump operating speed of 600 RPM. ***CHECK THE ROTATION OF THE PTO!*** If it is opposite of the engine, then the pump can be used as it is. If the PTO rotation is the same as the engine, then the pump will need to be reversed. (See instructions included with the pump.) Bolt the gear pump to the PTO output flange using 3/8 x 1" cap screws and lock washers.

The optional 6 GPM gear pump has an SAE 'B' mounting configuration, a 13 tooth splined shaft and a four-bolt mounting flange, and is assembled for rotation in either direction. *NOTE:* This pump will mount directly to Chelsea's output type 'XK' or Muncie's output type 'D'. Crysteel Manufacturing recommends a PTO ratio of 100–120%. This assures a minimum pump operating speed of 600 RPM. Bolt the gear pump to the PTO output flange using 1/2 x 1 1/4 cap screws and lock washers.

MOUNT RESERVOIR/VALVE ASSEMBLY

The reservoir/valve assembly should be mounted on the same side of the truck as the pump and as high as possible for reliable pump performance. The slotted end of the valve spool should be towards the front of the truck so the valve control cable can be easily connected. The mounting brackets for the reservoir/valve assembly can be used to mount the reservoir/valve assembly outside the truck frame or inside between the truck frame rail and the driveshaft. Determine where to mount the reservoir/valve assembly and bolt the mounting brackets to the reservoir/valve assembly using 3/8 x 1 cap screws, flat washers and hex lock nuts. Locate the reservoir/valve assembly and clamp the mounting brackets to the truck frame. See Fig. 4. If inside the truck frame, make sure there is enough clearance for the drive line and hot exhaust pipes. ***THE ENGINE EXHAUST MUST NEVER BLOW DIRECTLY ONTO THE RESERVOIR/VALVE ASSEMBLY.*** Insert the spacers in the mounting brackets and mark the truck frame for drilling using the pump mounting brackets as guides

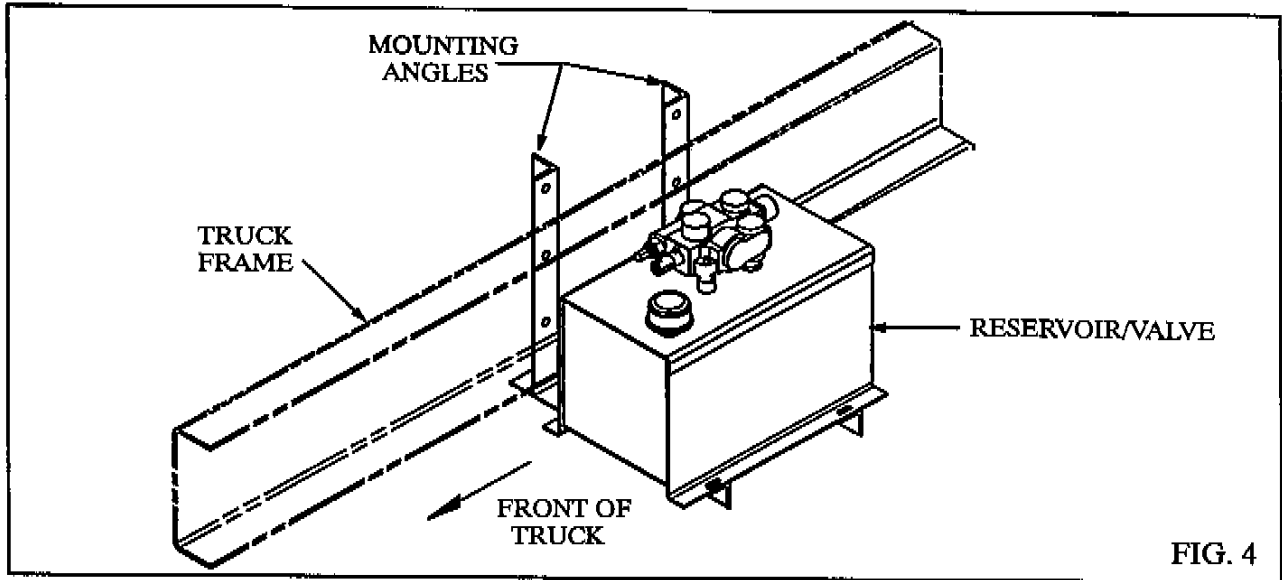

CAUTION: BE CAREFUL OF BRAKELINES, WIRING, ETC. INSIDE THE TRUCK FRAME WHEN DRILLING THE TRUCK FRAME.

Drill $17/32$ " holes in the truck frame and bolt the reservoir/valve assembly in place using $1/2 \times 2 \ 3/4$ cap screws, flat washers and hex lock nuts, tightening to 90 to 100 lb-ft.

INSTALL REMOTE VALVE CONTROL

Temporarily assemble the valve control head to the pedestal using $5/16 \times 2 \ 1/4$ " machine screws and hex nuts. Place this assembly on the floor of the cab. Make sure there is enough room to operate the valve control and the gear shift lever and to adjust the seat. Check below the floor for obstructions and cable routing. Relocate the valve control if necessary. Mark the floor using the pedestal as a template and drill $1/4$ " holes for the mounting screws and a $3/4$ " hole for the control cable. Assemble the control cable to the valve control head and assemble the valve control head and cover to the pedestal using $5/16 \times 2 \ 1/4$ " cap screws and hex lock nuts. Insert the control cable through the hole in the floor and mount the pedestal to the floor using $5/16 \times 1/2$ machine screws and hex lock nuts. Make sure the valve control lever is in its center detent position. Keep the control cable away from hot exhaust pipes and rotating drive shafts. The control cable should not have any sharp bends or kinks in it (these will make the control harder to operate).

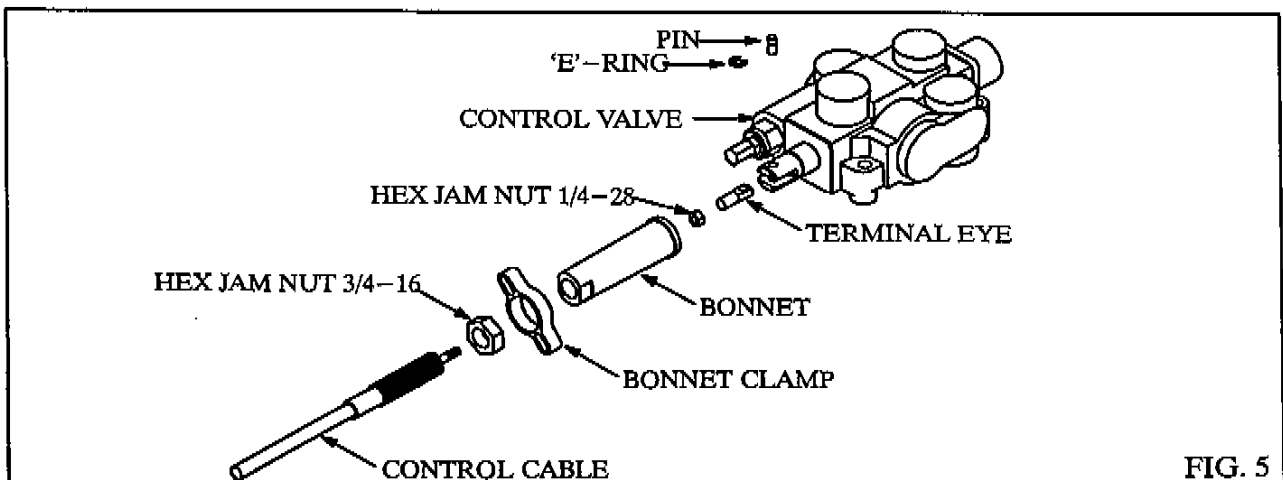

Install the 3/4" hex jam nut onto the valve end of the control cable and turn it past the threads. Insert the end of the cable through the bonnet clamp. Install the bonnet onto the control cable and turn it past the threads also. Install the 1/4" hex jam nut and terminal eye on the core rod of the cable. Lock the terminal eye to the core rod of the cable using the hex jam nut. Place the terminal eye in the slot of the valve spool; insert the short pin through the valve spool and terminal eye and secure it in place with the 'E' ring.

Thread the bonnet onto the end of the cable so it firmly touches the end of the valve. (Do not over- or under-tighten the bonnet as either would move the valve spool out of its neutral position.) Remove two cap screws from opposite corners of the seal retainer plate. Slide the bonnet clamp onto the bonnet and secure it to the valve using the 1/4 x 1 1/4" cap screws, lock washers and flat washers. Lock the bonnet to the cable using the 3/4" hex jam nut. See Fig. 5.

INSTALL 4 GPM PUMP HOSES

Study Fig. 6 very carefully before connecting the hoses. Install a 3/4" 90° street elbow and a 3/4" hose barb in the suction port on the bottom of the reservoir. Install a 1 1/16 ORB x 3/4" hose barb in the suction port of the pump and install a 3/4" ID suction hose. Secure the suction hose in place using hose clamps. Install a 1 1/16 ORB x 1/2 NPT 90° swivel adapter in the 'IN' port of the control valve and a 7/8 ORB x 1/2 NPT adapter in the pressure port of the pump. Connect a 72" long 1/2" ID hose between the pump and the valve.

INSTALL 6 GPM PUMP HOSES

Study Fig. 6 very carefully before connecting the hoses. Install a 3/4" 90° street elbow and a 3/4" hose barb in the suction port on the bottom of the reservoir. Install a 3/4" hose barb in the suction port of the pump and install the suction hose. Secure the suction hose in place using hose clamps. Install a 1 1/16 ORB x 1/2 NPT 90° swivel adapter in the 'IN' port of the control valve and install a 3/4 x 1/2 hex reducer in the pressure port of the pump. Install a 72" long 1/2" ID hose from the pump to the valve.

INSTALL CYLINDER HOSES – GEAR PUMP SYSTEMS

Install 90° swivel adapters in the work ports of the control valve and in the ports on the cylinder. Connect the 36" long 1/2" ID hose with 7/8 JIC fittings, from the 'B' port on the control valve to the base end port on the cylinder. Connect the 60" long 1/2" ID hose with 7/8 JIC fittings, from the 'A' port on the control valve to the rod end port on the cylinder. This will raise the hoist when the control lever is pulled back and lower it when pushed forward.

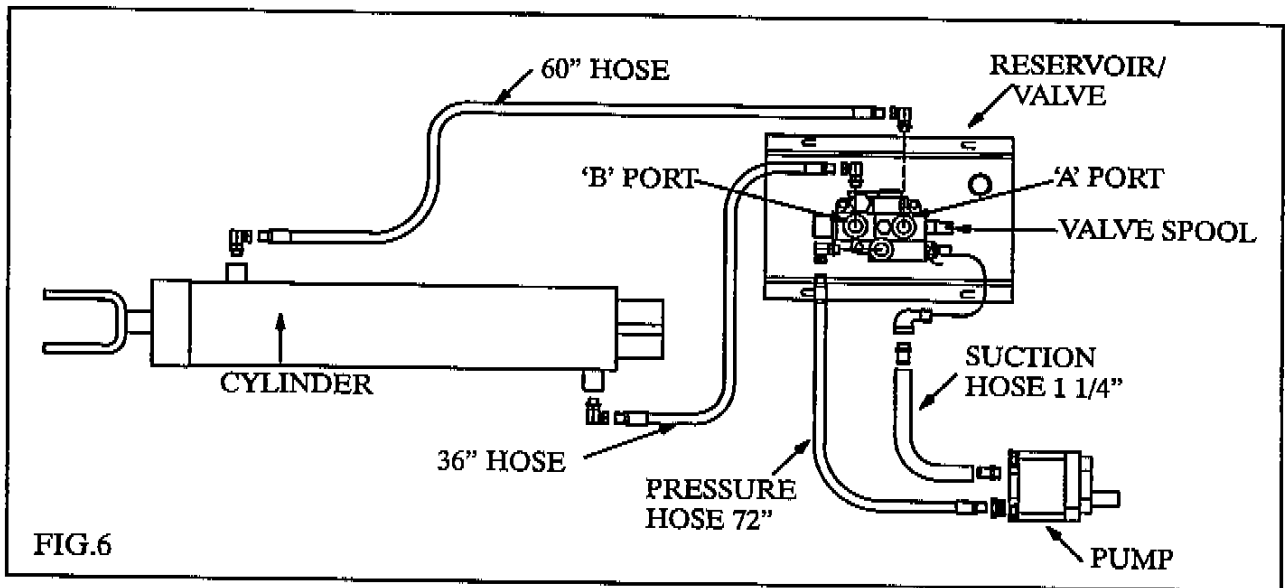

NOTE: The 'A' port is the 'power-down' port and has a pressure of only 500–1000 PSI; the 'B' port has full system pressure.

ELECTRIC PUMP MOUNTING – GENERAL

The electric power unit should be mounted close behind the cab, either inside or outside the truck frame. After determining where to mount the power unit, bolt one mounting angle to the power unit using the 3/8 x 1 hex head cap screws, tightening to 24 to 26 lb–ft. Clamp the mounting bracket to the truck frame. Clamp the second mounting angle to the truck frame so it supports the far end of the reservoir. Mark the truck frame for drilling using the pump mounting angles as guides.

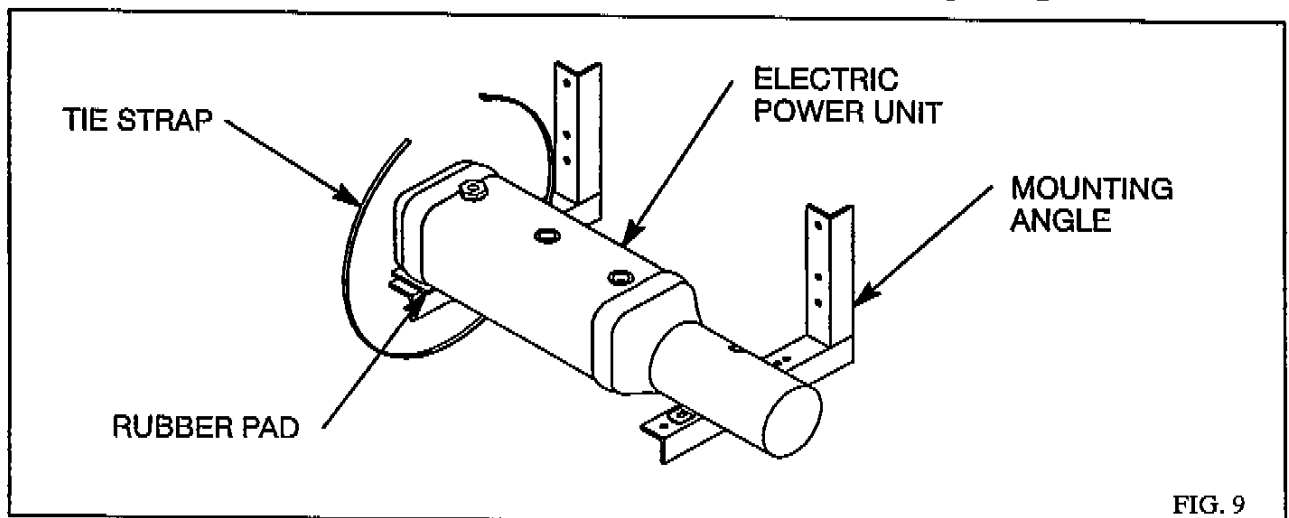

CAUTION: BE CAREFUL OF BRAKELINES, WIRING, ETC. INSIDE THE TRUCK FRAME WHEN DRILLING THE TRUCK FRAME.

Drill 17/32" holes in the truck frame and bolt the reservoir/valve assembly in place using 1/2 x 2 3/4 cap screws and hex lock nuts, tightening to 90 to 100 lb–ft.

Connect the large terminal on the motor start solenoid to the positive terminal on the battery with a #0 gauge battery cable. Connect the negative terminal on the battery to one of the mounting screws on the power unit using a #0 gauge battery cable, or equivalent size ground strap.

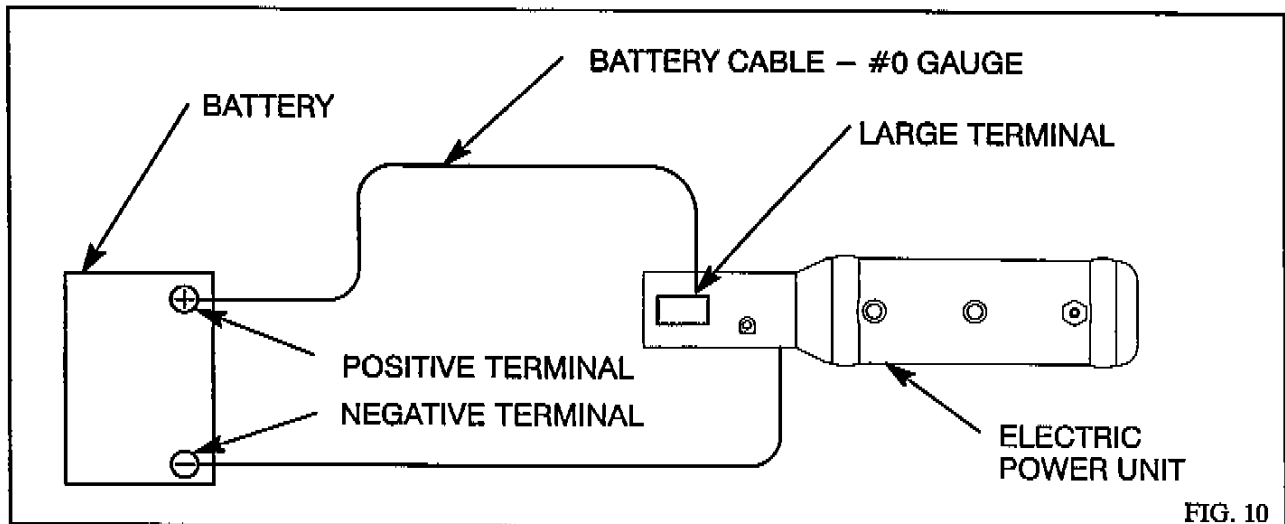

Locate the push-button control in the cab and route the cable out of the cab through a hole in the back of the cab. Connect the push-button control to the electric power unit using the 3-pin connector set.

INSTALL CYLINDER HOSES – SINGLE-ACTING ELECTRIC PUMP

Install 90° swivel adapters in the ports on the cylinder. Install a 3/8 NPT x 3/4-16 JIC male elbow in the power port on the pump and install the shorter hose between the power port on the pump and the base end port on the cylinder. Install a 1/4 NPT x 3/4-16 JIC male elbow in the port on the top of the reservoir and install the longer hose between the reservoir and the rod end port on the cylinder.

INSTALL CYLINDER HOSES – DOUBLE-ACTING ELECTRIC PUMP

Install 90° swivel adapters in the ports on the cylinder. Install 9/16 ORB x 3/4 JIC 90° swivel adapters in both work ports on the electric pump. If needed for good hose routing, install 3/4 JIC x 3/4 JIC 90° swivel adapters to both of these adapters. Connect the 42" long 3/8" ID hose with 3/4 JIC fittings from the 'C1' port on the pump to the base end port on the cylinder. Connect the 60" long 3/8" ID hose with 3/4 JIC fittings from the 'C2' port to the rod end port.

NOTE: The "C2" port is the power down port and has only 500 PSI maximum pressure.

ADD HYDRAULIC OIL

Use a quality hydraulic fluid of 150 SSU @ 100° F which contains corrosion and oxidation inhibitors and a foam depressant. This is approximately the equivalent of SAE 10W or lighter weight oil, or use Type A automatic transmission oil for improved performance in cold weather. Fill the hydraulic reservoir using the following table.

Standard or Optional Gear Pump w/ Valve-Tank	4 Gals
Electric – Single-Acting	15 Qts
Electric – Double-Acting	9 Qts

KEEP THE OIL CLEAN. USE CLEAN CONTAINERS, FUNNELS AND OTHER EQUIPMENT!

POWER HOIST DOWN

Before mounting the body, the hoist must be completely closed to make certain that the hoist gives full lift height and performance. Make sure the lift angles are straight up and down. Start the truck engine, engage the PTO and power down the hoist to "bottom-out" the hydraulic cylinder and the hoist frame. Place the hoist valve control in the "hold" position. Both the hoist frame and the hydraulic cylinder are now completely closed.

INSTALL CRYSTEEL TIPPER BODY ON TRUCK

Place the Tipper body on the subframe so the front of the body and the front end of the subframe are even. Make sure there is sufficient clearance between the body and the reservoir/valve assembly. Relocate the reservoir/valve assembly if necessary. Carefully align the body longbeams to the subframe rails. Securely weld the rear hinge bracket to the longbeams. Securely weld the hoist lift plates to the boxed-in sections of the longbeams.

INSTALL BODY ON TRUCK

Study the diagram in Fig. 7 before installing the body. Make sure there is enough clearance under the body for the hoist to fit. The inside of the longbeams should be boxed in to provide a flat surface for welding the body and hoist together. Carefully measure the location of the hoist lift plate and mark this location on the inside of the longbeams and box in the inside of the longbeams. Place the body on the truck with 3 to 5 inches of clearance behind the cab. Make sure there is sufficient clearance between the body and the reservoir/valve assembly. Relocate the reservoir/valve assembly if necessary. Carefully align the body longbeams to the subframe rails. Securely weld the rear hinge bracket to the longbeams. Securely weld the hoist lift plates to the boxed-in sections of the longbeams.

DO NOT WORK UNDER A RAISED BODY UNLESS THE BODY IS SECURELY BLOCKED OR PROPPED IN THE RAISED POSITION!

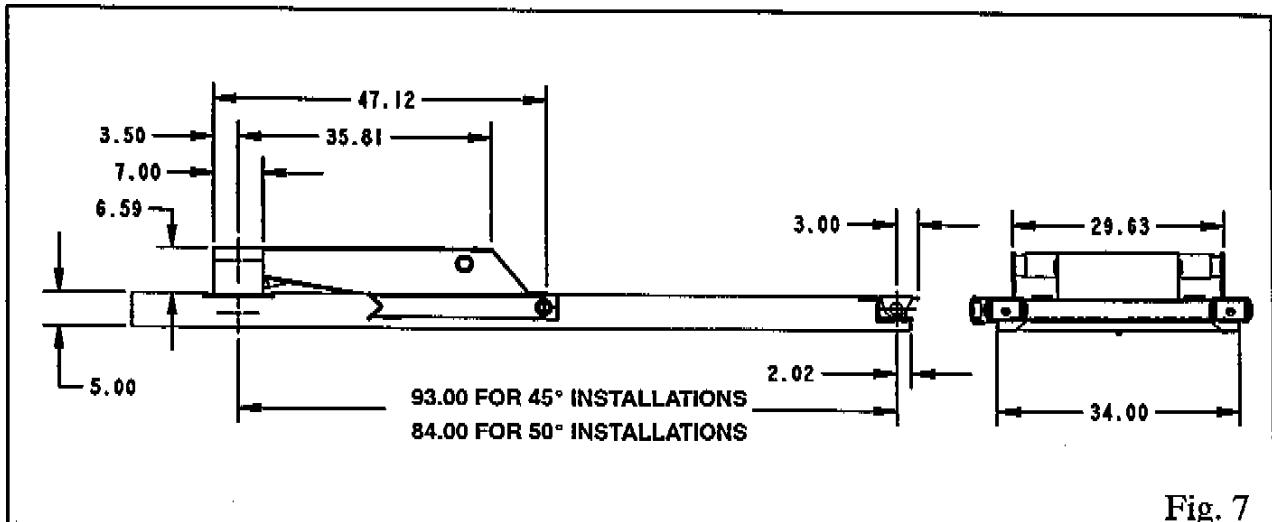

INSTALL BODY PROP BRACKET ON BODY LONGBEAM

The body prop is designed and intended to support an EMPTY truck body in the raised position. Using the body prop permits service work to be performed safely beneath a raised body. It is mounted on the outside of the subframe on the driver's side.

1. Raise the body more than half way up.
2. Raise the prop arm to a free standing position by allowing the prop arm to rest against the rear flange of the prop pivot. The top of the prop arm will swing in under the longbeam.
3. Slowly lower the body until the bottom of the longbeam rests on the body prop saddle. Place the longbeam bracket against the outside of the longbeam so the legs straddle the prop arm saddle. Securely weld this bracket to the body. (See Fig. 8.)
4. To operate the body prop, raise the body to the desired height, shut off all power, raise the prop arm to a free standing position. Lower the body slowly until the longbeam bracket contacts the prop arm saddle. **DO NOT POWER HOIST DOWN!**
5. To place the body prop in the storage position, raise the body to clear the body prop saddle, lower the body prop to the storage position and lower the body.

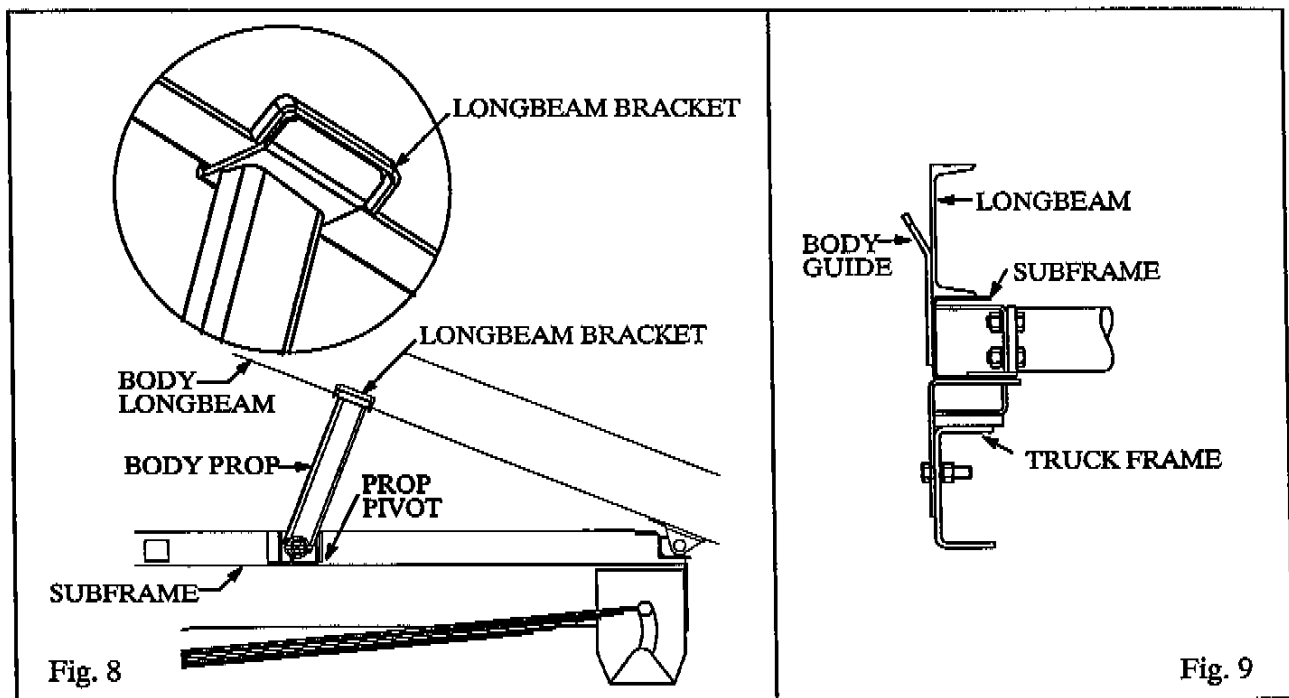

INSTALL BODY GUIDES

Two body guides have been included and should be mounted near the front of the subframe. Clamp the body guides to the outside of the subframe as shown in Fig. 9. The body guide should be tight against the outside of the longbeams of the body. Securely weld the body guides to the subframe.

INSTALL GREASE ZERKS AND LUBRICATE HOIST

Install grease zerks on the hoist and lubricate the hoist in the following locations:

Upper Crosstube	2 Fittings
Lower Crosstube	2 Fittings
Cylinder Base Pivot	1 Fitting
Rear Hinge (already installed)	2 Fittings
Body Prop (already installed)	1 Fitting

Lubricate all fittings at regular intervals, at least each time the truck chassis is lubricated. There are extremely high forces on the bearings surfaces within the hoist frame. It pays to be generous in lubricating the hoist to insure proper operation and long life.

The center hinge and the cylinder crosshead do not need to be greased. These pivot points are equipped with self lubricating composite bearings that do not need lubrication.

ONE OF THE MOST COMMON REASONS FOR HOIST PROBLEMS IS FAILURE BY THE OPERATOR TO LUBRICATE THE HOIST.

INSTALL DECALS

After the hoist is installed and the body has been painted, install the decals in the following locations:

- | | | | |
|----|-------|--------|--|
| 1. | Decal | 400640 | Mount in the cab above the valve control. |
| 2. | Decal | 400719 | Mount on the body longbeam near the body prop.
(one on each side) |
| 3. | Decal | 400661 | Mount on the body prop arm. |
| 4. | Decal | 401576 | Mount on the outside of the body longbeams near the front of the
body (one on each side). |
| 5. | Decal | 400643 | Mount on the body longbeam on the drivers side. |
| 6. | Decal | 401577 | Mount in the cab in a prominent location. |
| 7. | Decal | 400642 | Mount in the cab in a prominent location. |

See the illustrations on the following page for decal identification.

! OPERATION OF BODY PROP !

1. Raise body to full height and shut off all power.
2. Raise prop to upright position.
3. Lower body slowly until body bracket contacts prop.
4. **DO NOT POWER HOIST DOWN.**

400719

! DANGER !

- DO NOT GO UNDER RAISED BODY IT MAY DROP AND KILL YOU
- OPERATE HOIST CONTROLS ONLY FROM INSIDE TRUCK CAB



401576

! CAUTION !

- BODY MUST BE BRACED BEFORE SERVICING HOIST OR WORKING IN AREA WITH BODY IN RAISED POSITION
- LUBRICATE HOIST GREASE FITTINGS OFTEN - AT LEAST EACH TIME TRUCK IS SERVICED
- TRUCK MUST BE LEVEL FOR DUMPING
- DO NOT OVERLOAD

CRYSTEEL MFG., INC.

400643

! DANGER !

- DO NOT GO UNDER RAISED BODY IT MAY DROP AND KILL YOU
- OPERATE HOIST CONTROLS ONLY FROM INSIDE TRUCK CAB



401577

! CAUTION !

- BODY MUST BE BRACED BEFORE SERVICING HOIST OR WORKING IN AREA WITH BODY IN RAISED POSITION
- LUBRICATE HOIST GREASE FITTINGS OFTEN - AT LEAST EACH TIME TRUCK IS SERVICED
- TRUCK MUST BE LEVEL FOR DUMPING
- DO NOT OVERLOAD

CRYSTEEL MFG., INC.

400642

DOUBLE ACTING VALVE
OUT - RAISE; CENTER - HOLD; IN - LOWER
TO USE HYDRAULIC LOCK-DOWN

CONTINUE POWER DOWN UNTIL RELIEF VALVE BY-PASSES; THEN SET IN "HOLD" POSITION.

400640

! CAUTION !

UNLOAD BODY BEFORE USING BODY PROP.

400661

Fig. 12

LB520 HOIST PARTS

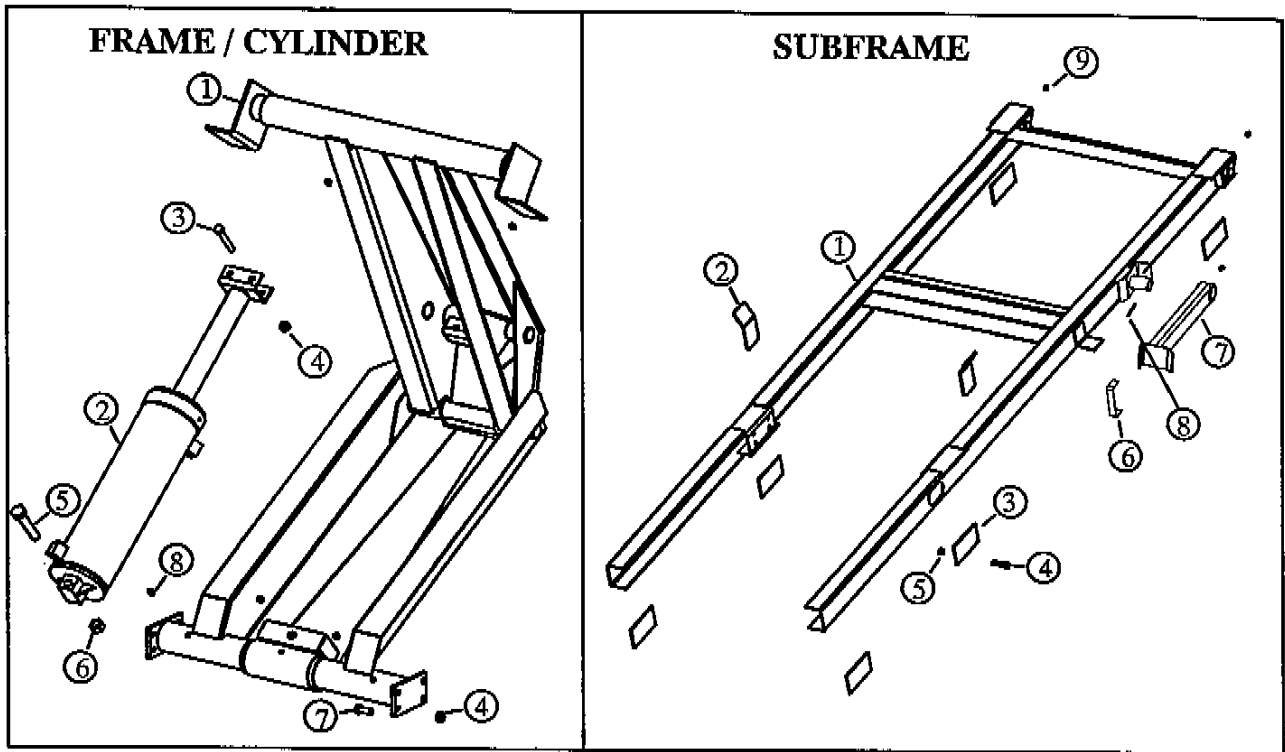

LB520 FRAME & CYLINDER PARTS

ITEM	DESCRIPTION	MODEL	PART NO.	QTY.
1.	Frame Assembly	LB520	104321	1
2.	Cylinder Assembly	LB520	104293	1
3.	Cap Screw 1/2-13 x 3 3/4 Gr 8	LB520	400138	2
4.	Hex Lock Nut 1/2-13	LB520	401316	10
5.	Cap Screw 3/4-10 x 4 1/2 Gr 8	LB520	401225	1
6.	Hex Lock Nut 3/4-10	LB520	401226	1
7.	Cap Screw 1/2-13 x 1 1/4 Gr 8	LB520	400153	8
8.	Grease Zerk 1/8 NPT	LB520	400103	5
9.	Frame & Cylinder Assembly	LB520	134573	1

LB520 SUBFRAME PARTS

ITEM	DESCRIPTION	MODEL	PART NO.	QTY.
1.	Subframe Assembly - 9' - 50°	LB520	134449	1
	Subframe Assembly - 10' - 50°	LB520	134450	1
	Subframe Assembly - 11' - 50°	LB520	134451	1
	Subframe Assembly - 12' - 50°	LB520	136645	1
	Subframe Assembly - 14' - 50°	LB520	136609	1
	Subframe Assembly - 16' - 50°	LB520	143676	1
	Subframe Assembly - 10' - 45°	LB520	134452	1
	Subframe Assembly - 11' - 45°	LB520	140033	1
	Subframe Assembly - 12' - 45°	LB520	138728	1
	Subframe Assembly - 14' - 45°	LB520	135308	1

2.	Body Guide	LB520	222812	2
3.	Mounting Plate	LB520	227988	2
4.	Cap Screw 5/8-11 x 2 Gr 8	LB520	402374	12
5.	Hex Lock Nut 5/8-11	LB520	401582	12
6.	Body Prop Bracket	LB520	276942	1
7.	Assy Body Prop Arm	LB520	150520	1
8.	Spring Pin 1/4 x 3	LB520	400220	1
9.	Grease Zerk 1/8 NPT	LB520	400103	3

LB520 HYDRAULIC SYSTEMS PARTS

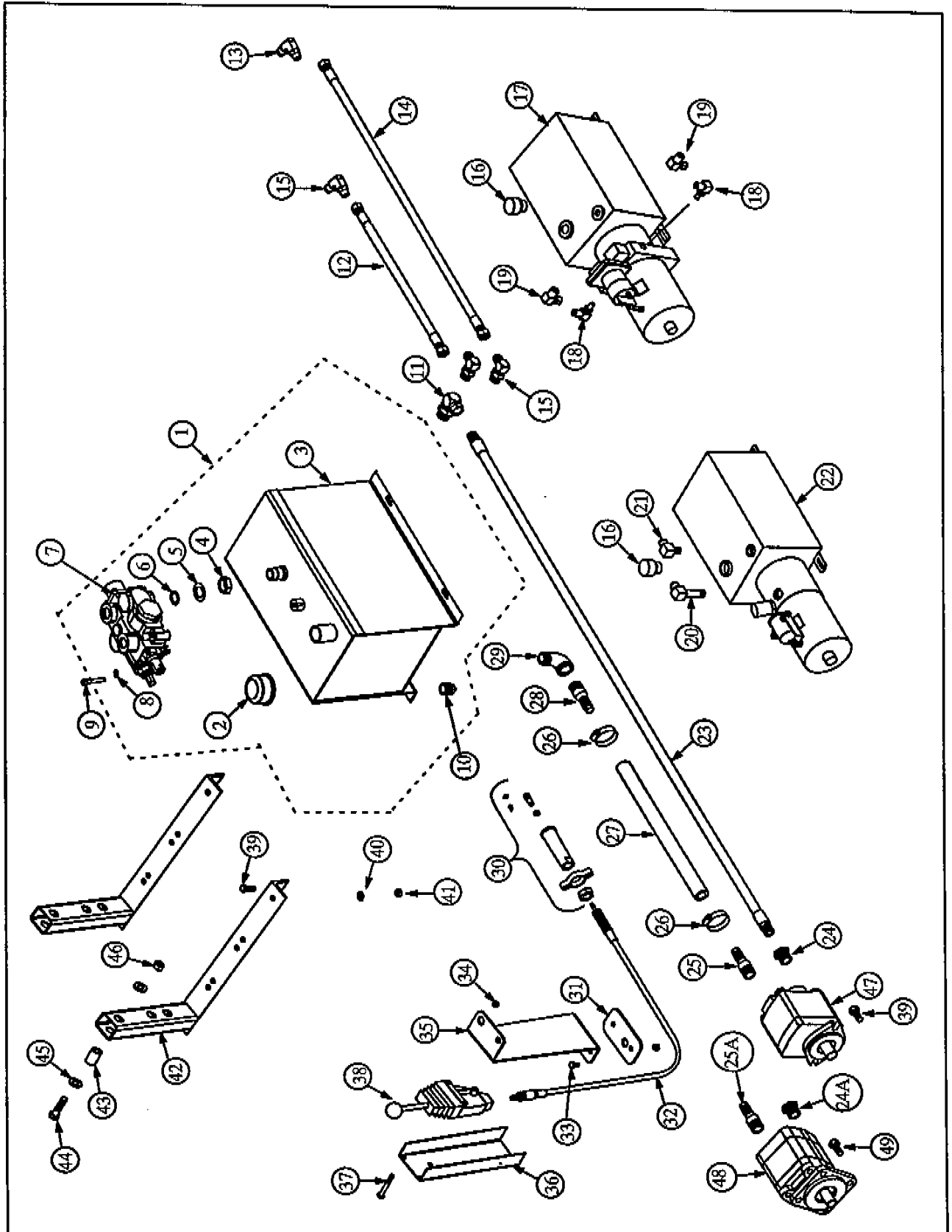

ITEM	DESCRIPTION	MODEL	PART NO.	QTY.
1.	Reservoir/Valve Carton (Includes Items 2 through 10)	LB520	116651	1
2.	Breather Cap	LB520	400764	1
3.	Reservoir Assembly	LB520	116361	1
4.	Hex Jam Nut 1 1/16-12	LB520	402092	1
5.	Washer 1 1/16 Cone	LB520	402093	1
6.	O-Ring .924 ID x .116 CS	LB520	401094	1
7.	Control Valve	LB520	402065	1
8.	Lock Washer 5/16	LB520	400165	1
9.	Cap Screw 5/16-18 x 2 Socket Head	LB520	402115	1
10.	Magnetic Pipe Plug 3/4"	LB520	400405	1
11.	Swivel Adapter 1 1/16 ORBM x 1/2 NPTF 90°	LB520	401285	1
12.	Hose 7/8 JICF x 36" Long, 1/2" ID	LB520	404403	1
	Hose 3/4 JICF x 48" Long, 1/2" ID	LB520 - ELEC	402490	1
13.	Adapter 3/4 ORBM x 7/8 JICM 90°	LB520	404415	1
	Adapter 3/4 ORBM x 3/4 JICM 90°	LB520 - ELEC	402487	1
14.	Hose 7/8 JICF x 60" Long, 1/2" ID	LB520	404404	1
	Hose 3/4 JICF x 72" Long, 1/2" ID	LB520 -- ELEC	404906	1
15.	Adapter 7/8 ORBM x 7/8 JICM 90°	LB520	404414	3
	Adapter 7/8 ORBM x 3/4 JICM 90°	LB520 - ELEC	402486	1
16.	Breather Cap, Electric Pumps	LB520	400776	1
17.	Pump Electric P/B D/A	LB520	405287	1
18.	Adapter 9/16 ORBM x 3/4 JICM 90°	LB520	403447	2
19.	Swivel Adapter 3/4 JICF x 3/4 JICM 90°	LB520	403448	2
20.	Adapter 3/8 NPTM X 3/4 JICM 90°, Extra Long	LB520	402509	1
21.	Adapter 1/4 NPTM X 3/4 JICM 90°	LB520	402510	1
22.	Pump Electric P/B S/A 20 Qt	LB520	405313	1
23.	Hose 1/2 NPTM x 60" Long, 1/2" ID	LB520	401445	1
24.	Adapter 7/8 ORBM x 1/2 NPTF	LB520	400473	1
24A.	Hex Bushing 3/4 NPT x 1/2 NPT	LB520	401091	1
25.	Hose Barb 1 1/16 ORBM x 3/4	LB520	402146	1
25A.	Hose Barb 3/4 NPTM x 3/4	LB520	401447	1
26.	Hose Clamp #24 1 1/16 - 2"	LB520	401441	2
27.	Suction Hose 3/4" ID x 72" Long	LB520	404911	1
28.	Hose Barb 3/4 NPTM x 3/4	LB520	401447	1
29.	Street Elbow 3/4 NPT 90°	LB520	402144	1
30.	Valve Connection Kit	LB520	402127	1
31.	Plate, Pedestal Clamping	LB520	225127	1
32.	Cable, Valve Control - 84"	LB520	402129	1
33.	Cap Screw 5/16-18 x 1/2	LB520	402415	2
34.	Hex Lock Nut 5/16-18	LB520	401240	5
35.	Pedestal Bracket - Wescon, Short	LB520	223143	1
	Pedestal Bracket - Wescon, Tall	LB520	223396	1
36.	Pedestal Cover - Wescon, Short	LB520	223144	1

	Pedestal Cover- Wescon, Tall	LB520	223397	1
37.	Machine Screw 5/16-18 x 2 1/2, Round Head	LB520	402154	3
38.	Remote Valve Control with Center Detent	LB520	402120	1
39.	Cap Screw 3/8-16 x 1 Hex Head	LB520	400121	6
40.	Flat Washer 3/8	LB520	400164	4
41.	Hex Lock Nut 3/8-16	LB520	402038	4
42.	Valve/Tank Mounting Assembly	LB520	135087	2
43.	Spacer, VT Mounting	LB520	253499	4
44.	Cap Screw 1/2-13 x 2 3/4 Hex Head	LB520	404426	4
45.	Flat Washer 1/2	LB520	400176	4
46.	Hex Lock Nut 1/2-13	LB520	401316	4
47.	Gear Pump - 4 GPM	LB520	402071	1
48.	Gear Pump - 6 GPM	LB520	400394	1
49.	Cap Screw 1/2-13 x 1 1/4 Hex Head	LB520	400153	4

LB520 CYLINDER PARTS

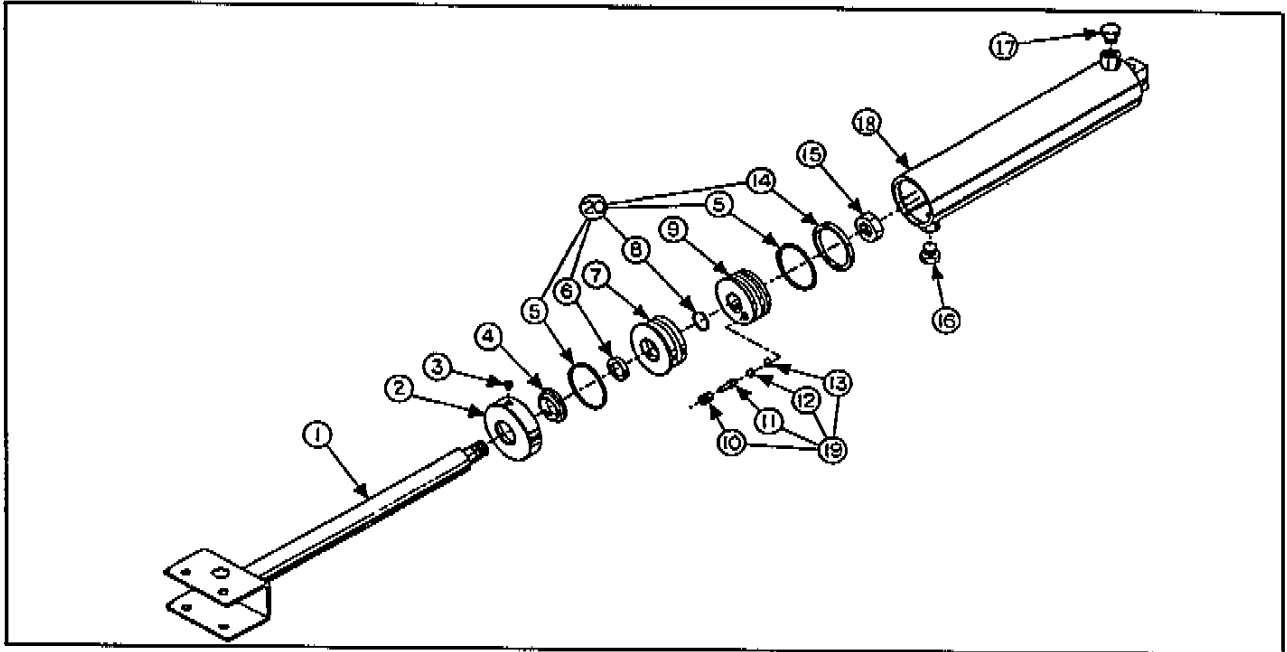

ITEM	DESCRIPTION	MODEL	PART NO.	QTY.
1.	Cylinder Shaft Assembly	LB520	104321	1
2.	Cylinder Cap Assembly	LB520	104293	1
3.	Set Screw, Nylon Tip 1/4 x 3/16	LB520	400149	1
4.	Wiper *	LB520	400913	1
5.	O-Ring *	LB520	400254	2
6.	Poly Seal *	LB520	400253	1
7.	Cylinder Head	LB520	202469	1
8.	O-Ring *	LB520	400255	1
9.	Cylinder Piston	LB520	402461	1
10.	Body Bypass Valve +	LB520	400978	1
11.	Pin Bypass Valve +	LB520	400979	1
12.	Steel Ball 3/8 +	LB520	400013	1
13.	O-Ring 1/16 x 7/16 +	LB520	401017	1
14.	Poly Seal	LB520	400252	1
15.	Hex Jam Nut 1 1/2-12	LB520	401370	1
16.	Plug 3/4 ORB	LB520	401389	1
17.	Plug 7/8 ORB	LB520	401390	1
19.	Cylinder Tube Assembly	LB520	104316	1
20.	Bypass Valve Kit (includes items with +)	LB520	105185	1
21.	Seal Kit (includes items with *)	LB520	107960	1
22.	Complete Cylinder Assembly	LB520	104242	1

LB520 LOAD CAPACITY IN TONS

BODY LENGTH	9'		10'			12'			14'			16'
Rear Overhang	6	18	6	18	30	6	18	30	6	18	30	30
Hoist Model LB520	12.1	16.0	10.8	13.8	19.0	8.9	10.8	13.8	7.6	8.9	10.8	8.9
Cab to Axle	72	60	84	72	60	108	96	84	132	120	108	132

N/R = Not Recommended

*Capacities at 45°, water level load, includes body weight.

CAUTION: The combined weights of truck, body, hoist and load must not exceed the Gross Vehicle Weight rating of the truck.**SPECIFICATIONS**

NTEA Class	Hoist Model	Cylinder Bore—Stroke Shaft	Operating Pressure PSI	Power Down PSI	Mounting Height	Minimum Longbeam Height	Subframe Height	Approx. Weight Pounds	Body Length Feet
C/40	LB520	5"–21.5/8"–2"	3250	800	12"	7"	5"	635	9 to 16

NOTES

SPECIALLY DESIGNED – WITH QUALITY IN MIND

WARRANTY

- Crysteel Manufacturing, Inc. warrants its products for a period of five (5) years from date of purchase.
- This warranty covers our products for defective material and/or workmanship at a rate of 100% for the first (3) years and at a rate of 50% for years (4) and (5).
- This warranty is all encompassing and covers all areas of our product including: Crysteel manufactured product, OEM products purchased by Crysteel, the repair of the warranted product, the replacement of warranted product, the labor to replace the warranted product, and both in and outbound freight for the replacement of the warranted product. This warranty is limited to products supplied under the Crysteel Mfg. name and does not cover distributor modifications. Primer warranty is limited to adherence to metal surfaces only and does not include the inside or understructure of the dump body or hoist.
- We will not assume responsibility for travel, loss of use, or downtime expenses.
- This warranty is void if the product has been obviously abused, or subjected to usage it was not designed for.
- Please contact your Crysteel Distributor for additional details.

! CAUTION !

- **BODY MUST BE BRACED BEFORE SERVICING HOIST OR WORKING IN AREA WITH BODY IN RAISED POSITION**
- **LUBRICATE HOIST GREASE FITTINGS OFTEN – AT LEAST EACH TIME TRUCK IS SERVICED**
- **TRUCK MUST BE LEVEL FOR DUMPING**
- **DO NOT OVERLOAD**

CRYSTEEL MFG, INC.

CRYSTEEL MANUFACTURING, INC.

P.O. Box 178 52182 Ember Road
Lake Crystal, MN 56055

1902 Route 57 South
Fulton, NY 13069

(507) 726-2728 (800) 533-0494